

# DATA SHEET

## 150 FRAME R-SERIES PLUNGER PUMPS



**Duplex Stainless Steel Models: 152R060, 152R080, 152R100**

**Flushed Models: 152R060C, 152R080C, 152R100C**

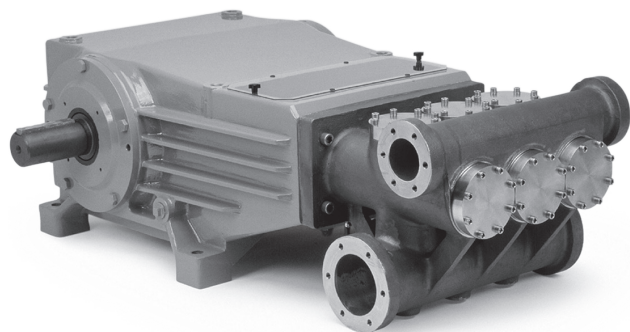

### FEATURES

- Triplex design delivers high-efficiency and low-pulsation.
- Durable dual V-packings are lubricated and cooled by pumped liquid.
- Pre-Set low-pressure seals provide secondary protection against external leaks and require no packing adjustment.
- Special high-density, polished, concentric plungers provide a true wear surface and extended seal life.
- Specially formulated seals and V-packings offer unmatched performance and extended seal life.
- Ceramic plungers, seals and V-packings are serviceable from the top of the crankcase permitting easy in-field servicing.

### COMMON

SPECIFICATIONS	U.S.	Metric
Inlet Pressure Range	Flooded to 50 psi	Flooded to 3.5 bar
Maximum Liquid Temperature	120° F	49° C
Stroke	5.91"	150 mm
Crankcase Capacity	22.4 gal	85 l
Lubrication	Splash	Splash
Inlet Ports (2) (Flange Required)	6.0"	150 mm
Discharge Ports (2) (Flange Req.)	4.0"	100 mm
Shaft Diameter	3.937"	100 mm
Weight	3087 lbs.	1400 kg
Dimensions	68.11 x 42.13 x 22.05"	1730 x 1070 x 560 mm

### SPECIFICATIONS

	U.S. Measure	Metric Measure
<b>152R060/152R060C</b>		
Flow	115 gpm	435 lpm
Pressure Range*	100 – 1200 psi	6.9 – 83 bar
Pump RPM**	360 rpm	360 rpm
Bore	2.375"	60.3 mm
<b>152R080/152R080C</b>		
Flow	200 gpm	757 lpm
Pressure Range*	100 – 1200 psi	6.9 – 83 bar
Pump RPM**	355 rpm	355 rpm
Bore	3.15"	80 mm
<b>152R100/152R100C</b>		
Flow	240 gpm	908 lpm
Pressure Range*	100 – 1000 psi	6.9 – 69 bar
Pump RPM**	270 rpm	270 rpm
Bore	3.94"	100 mm
<b>152R100 Alternate Specifications</b>		
Flow	280 gpm	1060 lpm
Maximum Pressure*	1000 psi	69 bar
Maximum RPM***	314 rpm	314 rpm

### 152R060 API

Flow	86 gpm	326 lpm
Barrels per Day (U.S. Petrol)	2948 bbl/d	—
Pressure Range*	100 – 1200 psi	6.9 – 83 bar
Pump RPM**	270 rpm	270 rpm
Bore	2.375"	60.3 mm

### 152R080 API

Flow	152 gpm	576 lpm
Barrels per Day (U.S. Petrol)	5211 bbl/d	—
Pressure Range*	100 – 1200 psi	6.9 – 83 bar
Pump RPM**	270 rpm	270 rpm
Bore	3.15"	80 mm

### 152R100 API

Flow	240 gpm	908 lpm
Barrels per Day (U.S. Petrol)	8228 bbl/d	—
Pressure Range*	100 – 1000 psi	6.9 – 69 bar
Pump RPM**	270 rpm	270 rpm
Bore	3.94"	100 mm

\*Relief pressure should be set at maximum 10% over system pressure.

\*\*Pump minimum is 75 RPM

\*\*\*Optimum inlet conditions required.

# PARTS LIST

ITEM	PART NUMBER	MATL	PART NUMBER	MATL	PART NUMBER	MATL	DESCRIPTION	QTY
	152R060/C		152R080/C		152R100/C			
2	890602	STL	890602	STL	890602	STL	Key (M28 x 16 x 170)	1
3	891238	STL	891238	STL	891238	STL	Screw, Grub (M20 x 20)	4
4	891275	SS	891275	SS	891275	SS	Plate, Serial No. (Not Shown)	1
5	891228	STL	891228	STL	891228	STL	Screw, HH (M20 x 60)	10
8	891235	F	891235	F	891235	F	Cover, Bearing	1
10	890215	FPM	890215	FPM	890215	FPM	O-Ring, Bearing Cover – 70D	2
11	890270	NBR	890270	NBR	890270	NBR	Seal, Oil	1
12	890230	POP	890230	POP	890230	POP	Shim Set	1
15	891240	STL	891240	STL	891240	STL	Bearing, Roller	2
20	891360	MZ	891360	MZ	891360	MZ	Rod, Connecting (Includes: 2-Sleeves, 2-Washers, 2-Screws) [03/09]	3
25	891361	CM	891361	CM	891361	CM	Crankshaft, Single End [03/09]	1
30	891230	F	891230	F	891230	F	Cover, Bearing, Blind	1
32	891234	NY	891234	NY	891234	NY	Cap, Filler with Gasket	1
35	891226	SS	891226	SS	891226	SS	Rivet (M2.9 x 6.5) (Not Shown)	6
36	891202	SS	891202	SS	891202	SS	Nameplate (Not Shown)	1
37	891233	—	891233	—	891233	—	Gauge, Oil Bubble With Gasket	1
40	890295	STL	890295	STL	890295	STL	Screw, HH (M16 x 50)	10
42	891237	SS	891237	SS	891237	SS	Washer, Flat (M8)	6
43	891225	SS	891225	SS	891225	SS	Screw, HSH (M8 x 15)	6
48	891232	AL	891232	AL	891232	AL	Plug, HH Drain	1
50	891250	F	891250	F	891250	F	Cover, Rear	1
52	891244	STL	891244	STL	891244	STL	Screw, Grub (M16)	2
53	891200	F	891200	F	891200	F	Crankcase	1
60	891201	PC	891201	PC	891201	PC	Cover, Rod Box	1
61	891224	SS	891224	SS	891224	SS	Screw, HSH (M10 x 15)	2
62	891282	STL	891282	STL	891282	STL	Pin, Roll (M6 x 25)	3
63	891280	F	891280	F	891280	F	Crosshead	3
64	891281	STL	891281	STL	891281	STL	Pin, Crosshead	3
65	891261	SS	891261	SS	891261	SS	Rod, Plunger	3
66	891236	RBR	891236	RBR	891236	RBR	Grommet, Cover	6
70	890275	PTFE	890275	PTFE	890275	PTFE	Seal, Oil – 70D [07/05]	3
77	890216	FPM	890216	FPM	890216	FPM	O-Ring, Carrier	3
80	891255	SS	891255	SS	891255	SS	Carrier, Oil Seal [07/05]	3
88	890347	SS	890347	SS	890347	SS	Insert, Plunger	3
90	<b>890415</b>	CC	—	—	—	—	Plunger (M60.3 x 257) (See Tech Bulletin 115)	3
—	—	—	<b>890416</b>	CC	—	—	Plunger (M80 x 257) (See Tech Bulletin 115)	3
—	—	—	—	—	<b>890417</b>	CC	Plunger (M100 x 257) (See Tech Bulletin 115)	3
95	890368	SS	890368	SS	890368	SS	Stud, (M20 x 200)	3
96	890336	PTFE	890336	PTFE	890336	PTFE	Back-Up Ring	3
97	890335	NBR	890335	NBR	890335	NBR	O-Ring, – 70D	3
98	890348	SSD	890348	SSD	890348	SSD	Gasket, Plunger Retainer	3
99	890312	SSD	890312	SSD	890312	SSD	Retainer, Plunger	3
102	<b>890372</b>	NAB	<b>890371</b>	NAB	<b>890370</b>	NAB	Adjuster, Packing	3
104	<b>890203</b>	NBR	<b>890204</b>	NBR	<b>890205</b>	NBR	O-Ring, Spacer – 70D	3
—	<b>890227</b>	FPM	<b>890314</b>	FPM	—	—	O-Ring, Spacer – 70D	3
105	<b>890580</b>	SSD	<b>890332</b>	SSD	<b>890333</b>	SSD	Case, Seal [01/11]	3
106	<b>890565</b>	NBR	<b>890566</b>	NBR	<b>890567</b>	NBR	Seal, LPS	3
—	<b>890561</b>	FPM	<b>890563</b>	FPM	<b>890564</b>	FPM	Seal, LPS	3
118	890389	SSD	890389	SSD	890389	SSD	Plug, [1/16" NPT(M)]	3
124	<b>890352</b>	SSD	<b>890351</b>	SSD	<b>890350</b>	SSD	Housing, Seal	3
127	<b>890520</b>	SFTK	<b>890521</b>	SFTK	<b>890522</b>	SFTK	V-Packing, Set	3
129	890202	NBR	890202	NBR	890202	NBR	O-Ring, Housing – 70D	3
—	<b>890228</b>	FPM	<b>890228</b>	FPM	<b>890228</b>	FPM	O-Ring, Housing – 70D	3
130	890591	PTFE	890591	PTFE	890591	PTFE	Back-up Ring, Housing	6
145	890589	D	890589	D	890589	D	Ring, Sealing	3
163	890201	NBR	890201	NBR	890201	NBR	O-Ring, Seat – 70D	6
—	<b>890229</b>	FPM	<b>890229</b>	FPM	<b>890229</b>	FPM	O-Ring, Seat – 70D	6
164	890260	SSD	890260	SSD	890260	SSD	Seat, FV	6
166	890427	D	890427	D	890427	D	Valve, FV (See Tech Bulletin 116)	6
167	890428	SS	890428	SS	890428	SS	Spring (See Tech Bulletin 116)	6
168	890429	D	890429	D	890429	D	Retainer, Spring (See Tech Bulletin 116)	6
171	890280	SSD	890280	SSD	890280	SSD	Stud, Valve Guide	6
172	890217	NBR	890217	NBR	890217	NBR	O-Ring, Plug – 70D	6
—	<b>890245</b>	FPM	<b>890245</b>	FPM	<b>890245</b>	FPM	O-Ring, Plug – 70D	6
174	890290	SSD	890290	SSD	890290	SSD	Plug, Valve Inlet	3
175	891229	SS	891229	SS	891229	SS	Screw, HSH (M12 x 55)	48
176	891290	SSD	891290	SSD	891290	SSD	Plug, Valve Discharge	3
185	892012	SSD	892012	SSD	892012	SSD	Head, Manifold	1
188	890221	STTC	890221	STTC	890221	STTC	Screw, HSH (M20 x 80)	8
200	892016	POP	892016	POP	892016	POP	Barb, 1/4" NPT x 1/4" Barb	6
201	892018	RBR	892018	RBR	892018	RBR	Hose, 9" x 1/4" LOP	3
202	892019	SS	892019	SS	892019	SS	Clamp, 1/4" Hose	6
290	890999	—	890999	—	890999	—	Loctite® 641, 10ML	1
295	891102	—	891102	—	891102	—	Drive-end w/o Plungers (Includes: Items 2 through 80, 349, 351, 352) [07/05]	1
296	<b>890395</b>	CC	<b>890396</b>	CC	<b>890397</b>	CC	Assembly, Plunger (Includes: Items 88, 90, 95, 96, 97, 98, 99) (See Tech Bulletin 115)	3
297	891112	SSD	891112	SSD	891112	SSD	Assembly, Head (Includes: Items 163 through 202) [07/05]	1
299	<b>892111</b>	SSD	<b>892112</b>	SSD	<b>892113</b>	SSD	Head, Complete (Includes: Items 102 through 145, 297)	1

# EXPLODED VIEW

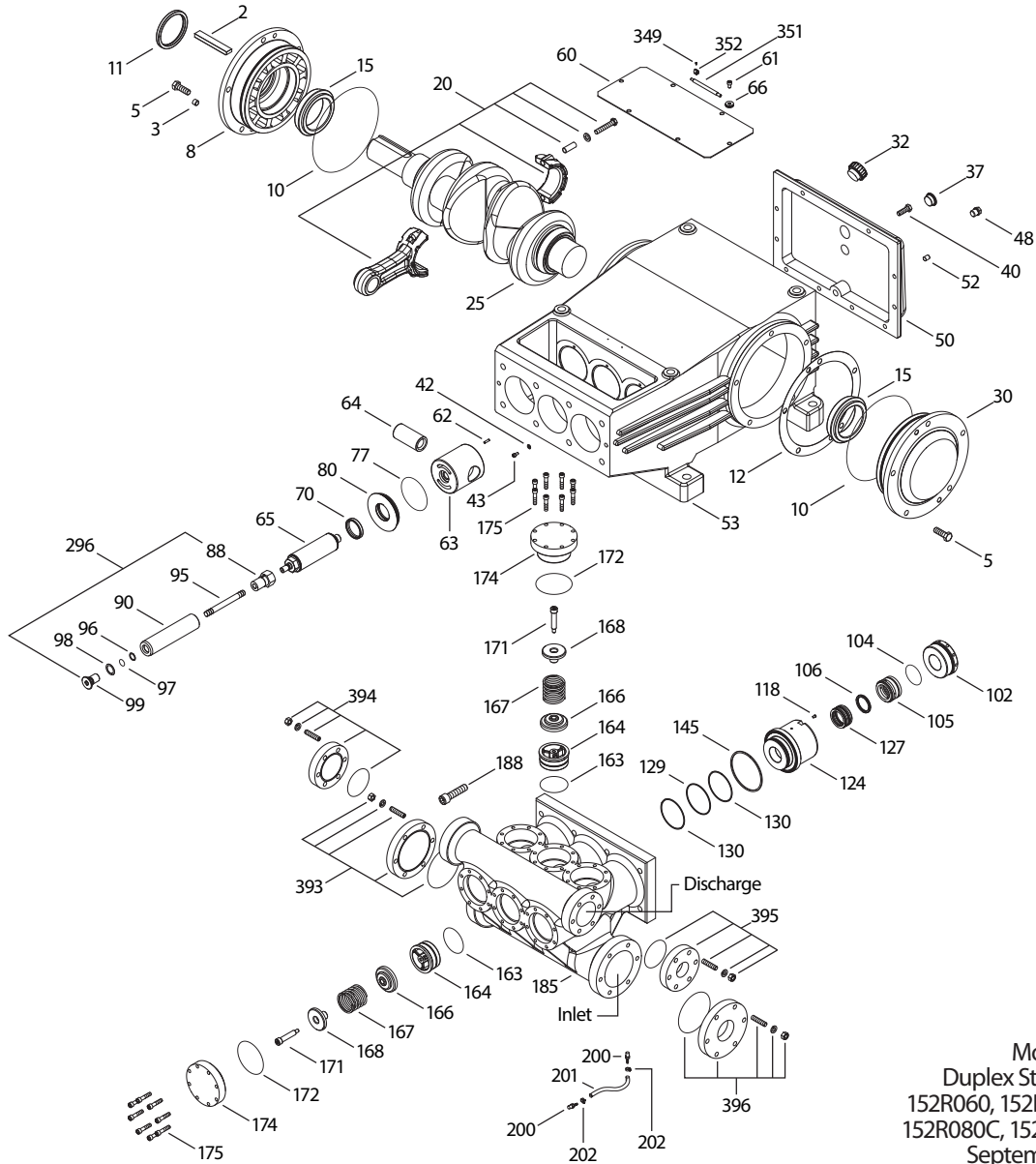

Models  
Duplex Stainless Steel  
152R060, 152R060C, 152R080  
152R080C, 152R100, 152R100C  
September 2020

ITEM	PART NUMBER	MATL	PART NUMBER	MATL	PART NUMBER	MATL	DESCRIPTION	QTY
300	<b>890036</b>	NBR*	<b>890037</b>	NBR*	<b>890038</b>	NBR*	Kit, Seal (Includes: 70, 77, 96, 97, 104, 106, 127)	1
	—	—	<b>891037</b>	FPM*	—	—	Kit, Seal (Includes: 70, 77, 96, 97, 104, 106, 127) [07/05]	1
310	890020	NBR	890020	NBR	890020	NBR	Kit, Valve (Includes: 163, 164, 166, 167, 168, 171, 172, 290)	2
	890022	NBR	890022	NBR	890022	NBR	Kit, Valve w/o Seat (Includes: 166, 167, 168, 171, 172)	2
349	891231	SS	891231	SS	891231	SS	Screw, HSH (M3 x 5)	2
351	890990	SS	890990	SS	890990	SS	Tool, Packing Adjuster	1
352	890998	STZP	890998	STZP	890998	STZP	Clip, Tool	2
370	998605	—	998605	—	998605	—	Flushing Assembly, 5 GPM, 10 PSI (152R060C, 152R080C, 152R100C)	1
390	719500	SS	719500	SS	719500	SS	C.A.T. (Inlet pressure stabilizer for RO and boosted inlet applications)	1
—	<b>890700</b>	SS	<b>890702</b>	SS	<b>890704</b>	SS	Valve, Relief 2"	1
—	701557	SS	701557	SS	701557	SS	Dampener, Pulsation (NBR Bladder)	1
393	892092	SS	892092	SS	892092	SS	Flange, Blank, Inlet (Specify Flange Type When Ordering)	1
394	892093	SS	892093	SS	892093	SS	Flange, Blank, Discharge (Specify Flange Type When Ordering)	1
395	892096	SS	892096	SS	892096	SS	Flange, Discharge 2" NPT (Specify Flange Type When Ordering)	1
396	892088	SS	892088	SS	892088	SS	Flange, Inlet 3" NPT (Specify Flange Type When Ordering)	1
—	6119	—	6119	—	6119	—	Lubricant, Antiseize (2 oz.) (See Tech Bulletin 095)	1
—	6116	—	6116	—	6116	—	Oil, Drum (16 gal.) ISO 100 Multi-viscosity Hydraulic (Fill to specified crankcase capacity prior to start-up)	1-2

Loctite is a registered trademark of the Henkel Corporation.

**Bold print part numbers are unique to a particular pump model. Italics are optional items.**

For additional technical information see [www.catpumps.com/literature/tech-bulletins](http://www.catpumps.com/literature/tech-bulletins).

[ ] Date of latest production change. \*Review material codes for individual items (SFTK generally may be used as alternate).

MATERIAL CODES (Not Part of Part Number): AL=Aluminum CC=Ceramic CM=Chrome-Moly D=Acetal F=Cast Iron FPM=Fluorocarbon MZ=Mazak NAB=Nickel Aluminum Bronze  
NBR=Medium Nitrile (Buna-N) NY=Nylon PC=Polycarbonate POP=Polypropylene PTFE=Pure Polytetrafluoroethylene RBR=Rubber SFTK=Polytetrafluoroethylene/Aramid Fiber Blend SS=316SS  
SSD=Duplex Stainless STL=Steel STTC=Steel PTFE Coated STZP=Steel/Zinc Plated

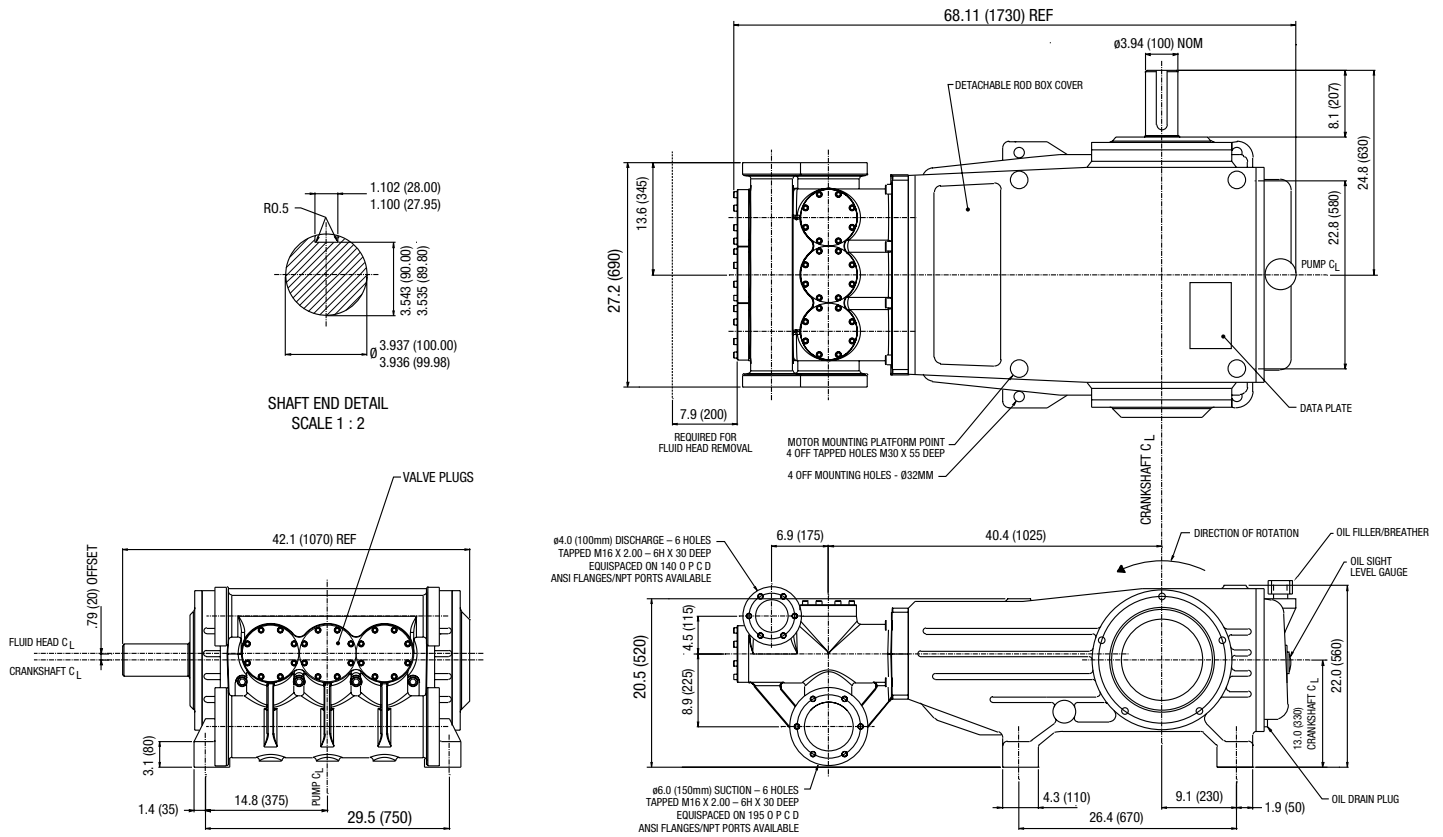

#### ⚠ CAUTIONS AND WARNINGS

All high-pressure systems require a primary pressure regulating device (i.e. regulator, unloader) and a secondary pressure relief device (i.e. pop-off valve, relief valve). Failure to install such relief devices could result in personal injury or damage to pump or property. Cat Pumps does not assume any liability or responsibility for the operation of a customer's high-pressure system.

Read all CAUTIONS and WARNINGS before commencing service or operation of any high-pressure system. The CAUTIONS and WARNINGS are included in each Service Manual and with each Accessory Data sheet. CAUTIONS and WARNINGS can also be viewed online at [www.catpumps.com/dynamic-literature/cautions-and-warnings](http://www.catpumps.com/dynamic-literature/cautions-and-warnings) or can be requested directly from Cat Pumps.

#### WARRANTY

View the Limited Warranty on-line at [www.catpumps.com/literature/cat-pumps-limited-warranty](http://www.catpumps.com/literature/cat-pumps-limited-warranty)