

DATA SHEET

7CP PLUNGER PUMPS



Stainless Steel Models

**7CP6111CS,
7CP6171CS**

Stainless Steel Flushed Models

**7CP6111CCS,
7CP6171CCS**

Gearbox Model

7CP6111CSG1

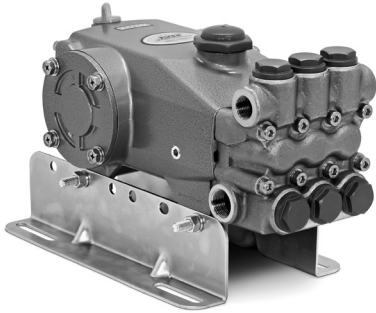

Model 7CP6171CS Shown
(Rails sold separately)

FEATURES

- Triplex plunger design ensures high efficiency and low pulsation.
- Belt-driven option provides precise flow settings.
- Gearbox models available with 1" or 1½" hollow shaft to fit most common engines.
- Models 7CP6111CCS and 7CP6171CCS offer an external flush for high-temperature or low lubricity-liquids.
- Direct-drive option offers a compact foot print for electric motors with a NEMA or IEC frame, or SAE hydraulic motors with a bell housing/flexible coupler assembly.
- Pump comes standard with NBR seals. Alternative seal materials are available for higher temperature or chemical compatibility.

COMMON

SPECIFICATIONS	U.S.	Metric
Inlet Pressure Range	Flooded to 70 psi	Flooded to 4.8 bar
Max. Liquid Temperature (NBR)	140° F	60° C
Alternative seals available for higher temperatures up to 200° F		
Bore	0.866"	22 mm
Crankcase Capacity	38 oz	1.15 l
Inlet Ports (2)	¾" NPT(F)	¾" NPT(F)
Discharge Ports (2)	½" NPT(F)	½" NPT(F)
Flush Ports (2) (7CP6111CCS, 7CP6171CCS)	⅛" NPT(F)	⅛" NPT(F)
Shaft Diameter	0.945"	24 mm
Weight (7CP6111CS, 7CP6171CS)	29.1 lbs	13.2 kg
Weight (Gearbox Models)	38.6 lbs	17.5 kg
Dimensions (Pump)	13.46 x 9.25 x 6.89"	342 x 235 x 175 mm
Dimensions (Gearbox)	13.46 x 12.24 x 6.97"	342 x 311 x 177 mm

SPECIFICATIONS

	U.S. Measure	Metric Measure
7CP6111CS, 7CP6111CCS		
Flow	10.5 gpm	40 lpm
Pressure Range	100–2000 psi	6.9–138 bar
Pump RPM*	1750 rpm	1750 rpm
Stroke	0.854"	21.7 mm

7CP6171CS, 7CP6171CCS

Flow	11 gpm	41.6 lpm
Pressure Range	100–2000 psi	6.9–138 bar
Pump RPM*	1450 rpm	1450 rpm
Stroke	1.024"	26 mm

7CP6111CSG1

Flow	10.0 gpm	38 lpm
Pressure Range	100–2000 psi	6.9–138 bar
Engine RPM	3400 rpm	3400 rpm
Stroke	0.854"	21.7 mm

*Pump is minimum 100 RPM

ALTERNATE

SPECIFICATIONS

	U.S. Measure	Metric Measure
7CP6171CS, 7CP6171CCS		
Flow	12.0 gpm	45.4 lpm
Pressure Range	100–1800 psi	6.9–124 bar
Pump RPM*	1600 rpm	1600 rpm

ALTERNATIVE SEAL CONFIGURATION

MATERIAL	SUFFIX CODE	MAXIMUM TEMPERATURE	
NBR	—	140° F	(60° C)
FPM	.0110	180° F	(82° C)
EPDM	.0220	160° F	(71° C)
IPFE	.0770	200° F	(93° C)
HT	.3000	180° F	(82° C)
STHT	.3400	190° F	(88° C)

See **Tech Bulletin 002** for inlet conditions and RPM at high temperature.

DETERMINING THE PUMP RPM	Rated gpm	=	Desired gpm
	Rated rpm	=	Desired rpm
DETERMINING THE REQUIRED HP	hp (Electric Brake)	=	gpm x psi 1460
	DETERMINING MOTOR PULLEY SIZE	Motor Pulley OD Pump rpm	=

Refer to pump **Service Manual** for repair procedure and additional technical information.

PARTS LIST

ITEM	P/N	MATL	DESCRIPTION	QTY
5	49651	S	Screw, HHC Sems (M8 x 20) (See Tech Bulletin 074)	8
8	131405	ALE	Cover, Bearing (See Tech Bulletin 123)	1
9	49503	FBR	Shim, Split, 2-Piece, Outer (See Tech Bulletin 123)	0-2
10	12393	NBR	O-Ring, Bearing Cover-70D	2
11	49190	NBR	Seal, Oil Crankshaft	1/2
12	49504	S	Shim, Split, 2-Piece, Inner (See Tech Bulletin 123)	0-2
15	63479	STL	Bearing, Roller	2
20	48727	TNM	Rod, Connecting Assembly (See Tech Bulletin 074)	3
25	49498	FCM	Crankshaft, Single-End (M21.7) (7CP6111CS, 7CP6111CCS, 7CP6111CSG1)	1
	49649	FCM	Crankshaft, Single-End (M26) (7CP6171CS, 7CP6171CCS)	1
30	131407	ALE	Cover, Blind Bearing (See Tech Bulletin 123)	1
32	43211	ABS	Cap, Oil Filler	1
33	14177	NBR	O-Ring, Oil Filler Cap-70D	1
36	129343	RBR	Gasket, Flat	1
37	92241	PC	Gauge, Oil, Bubble with Gasket-80D (See Tech Bulletin 074)	1
38	44428	NBR	Gasket, Flat, Oil Gauge-80D	1
39	49948	ABS	Stick, Dip (See Tech Bulletin 130)	1
40	92538	S	Screw, HHC Sems (M6 x 16) (See Tech Bulletin 074)	4
48	25625	STCP	Plug, Drain (1/4" x 19 BSP)	1
49	23170	NBR	O-Ring, Drain Plug-70D	1
50	131403	ALE	Cover, Rear (See Tech Bulletin 123)	1
51	14030	NBR	O-Ring, Rear Cover-70D	1
53	131400	ALE	Crankcase (See Tech Bulletin 123)	1
64	46969	CM	Pin, Crosshead	3
65	49637	SS	Rod, Plunger	3
70	48281	NBR	Seal, Oil Crankcase	3
75	43328	S	Slinger, Barrier	3
90	48559	CC	Plunger, Ceramic (M22 x 55)	3
95	49639	SS	Stud, Plunger Retainer (M6 x 50)	3
96	43235	PTFE	Backup Ring, Plunger Retainer	3
97	17399	NBR	O-Ring, Plunger Retainer-80D	3
98	44041	SS	Gasket	3
99	44031	SS	Retainer, Plunger (M6) (See Tech Bulletin 074)	3
100	46964	NY	Retainer, Seal	3
106	49644	NBR	Seal, LPS with SS-Spring	3
120	49643	SS	Case, Seal	3
121	13984	NBR	O-Ring, Seal Case-70D	3
127	48278	STG	V-Packing	6
128	49646	SS	Adapter, Male	3
162	43248	PTFE	Backup Ring, Seat	6
163	43249	NBR	O-Ring, Seat-80D	6
164	44037	SS	Seat	6
166	44038	SS	Valve	6
167	44039	SS	Spring	6
168	44564	PVDF	Retainer, Spring	6
172	17617	NBR	O-Ring, Valve Plug-90D	6
174	49293	SS	Plug, Valve (See Tech Bulletin 074)	6
185	49641	SS	Head, Manifold	1
	49972	SS	Head, Manifold Flushed (1/8" Flushed Port)	1
188	49647	S	Screw, HSH (M8 x 70) (See Tech Bulletin 074)	8
500	8081	—	Gearbox 1" Shaft (See Individual Data Sheet)	1
	8072	—	Gearbox 1 1/8" Shaft (See Individual Data Sheet)	1

Bold print part numbers are unique to a particular pump model. Italics are optional items. R Components comply with RoHS Directive.

*Review individual parts in each kit for material code identification. For additional technical information see www.catpumps.com/literature/tech-bulletins.

MATERIAL CODES (Not Part of Part Number): ABS=ABS Plastic ALE=Aluminum Epoxy CC=Ceramic CM=Chrome-moly EPDM=Ethylene Propylene Diene Monomer

F=Cast Iron FBR=Fiber FCM=Forged Chrome-moly FPM=Fluorocarbon NBR=Medium Nitrile (Buna-N) NY=Nylon PC=Poly Carbonate PE=Polyethylene

PTFE=Pure Polytetrafluoroethylene PVDF=Polyvinylidene Fluoride RBR=Rubber S=304SS SS=316SS ST=Special PTFE STG=Special Blend PTFE White

STHT=Special PTFE High Temp STL=Steel STCP=Steel/Chrome Plated STZP=Steel/Zinc Plated TNM=Special High Strength

EXPLODED VIEW

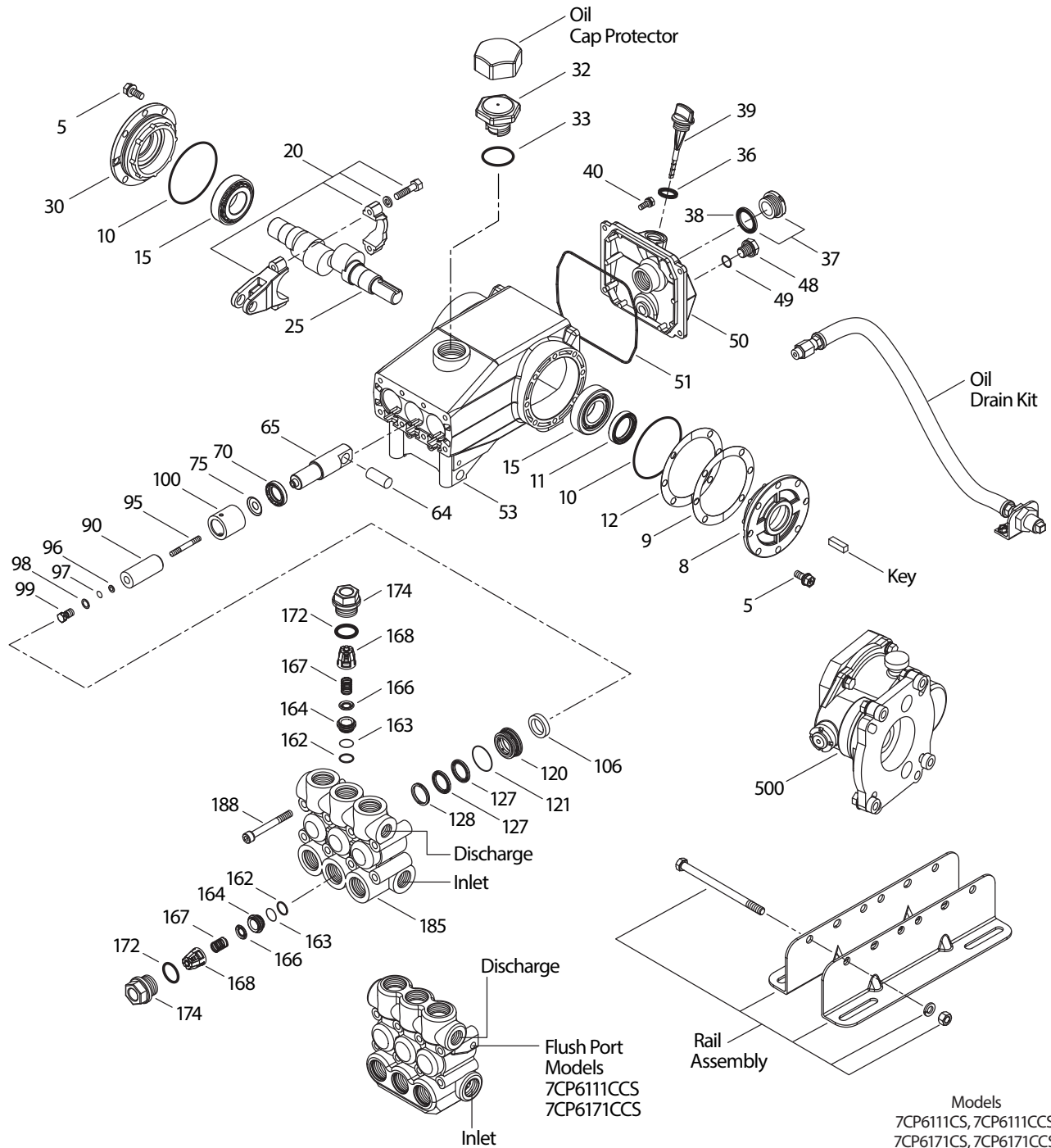

July 2021

OPTIONAL PARTS AND ACCESSORIES

PART	DESCRIPTION	QTY
30067	Key (M8 x 7.5 x 25)	1
30613	Rail Assembly (5.75" See Dimensional Drawing)	1
76513	Rail Assembly (6.25" See Dimensional Drawing)	1
828710	Protector, Oil Cap	1
34334	Kit, Oil Drain	1
30206	Pulley, 10" 2 Groove, "H"	1
33000	Hub, "H" 24mm	1
30696	Pliers, Reverse	1

SERVICE PARTS

PART	DESCRIPTION	QTY
76933	Kit, Seal—Standard NBR	1
76387	Kit, Valve—Standard NBR	2
6107	Oil, Bottle (21 oz)	2
6139	Lubricant, Anti-Seize (8 oz)	1
6124	Gasket, Liquid (3 oz)	1
818456	Head, Complete—with NBR Seals and O-Rings (Models 7CP6111CS, 7CP6111CSG1, 7CP6171CS)	1

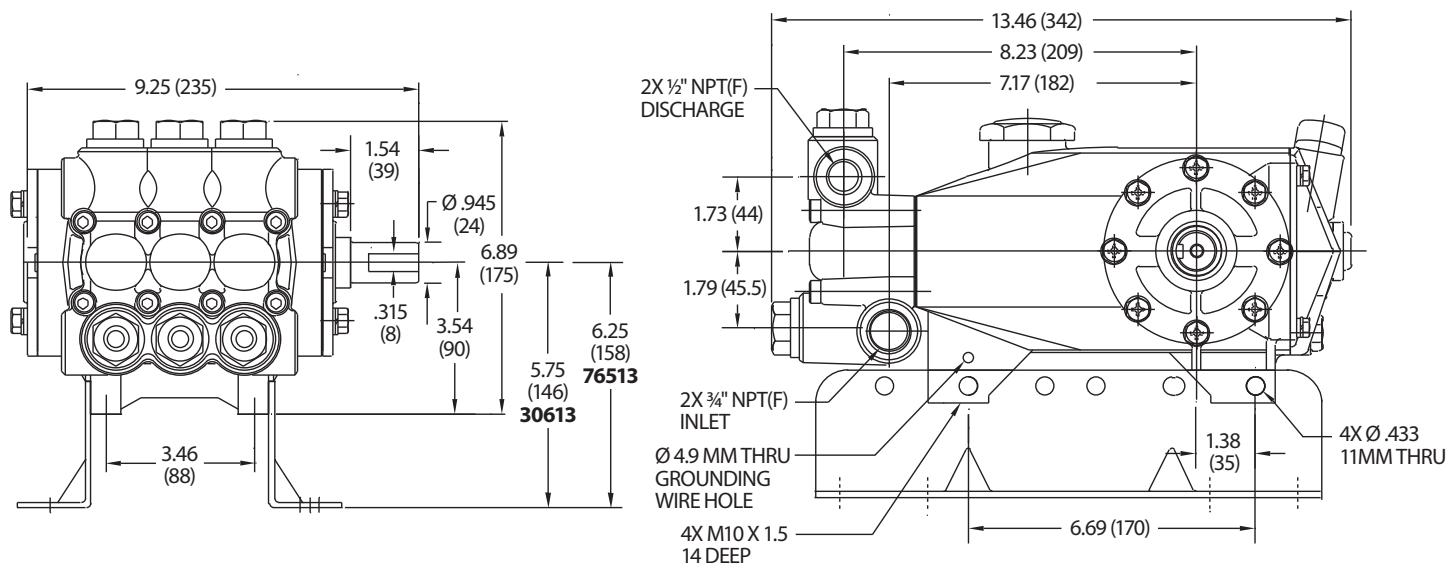

Models 7CP6111CS and 7CP6171CS

SEAL KITS One (1) seal kit required per pump

PUMP MODELS	NBR (STD)	FPM (.0110)	EPDM (.0220)◆	STHT (.3400)	IPFE (.0770)
7CP6111CS, 7CP6111CCS, 7CP6111CSG1, 7CP6171CS, 7CP6171CSS	76933	76950	31936	76068	32128

ITEM (Included in Seal Kits)						DESCRIPTION	QTY
97	17399	14160	46204	17399	701715	O-Ring, Plunger Retainer	3
106	49644	49704	48650	76704	76704	Seal, LPS with SS-Spring	3
121	13984	14333	701945	13984	703313	O-Ring, Seal Case	3
127	48278	48278	48278	48278	48278	V-Packing	6

◆ Silicone oil/grease required

*Review material codes for individual items (STG generally maybe used as alternative)

VALVE KITS Two (2) valve kits required per pump

PUMP MODELS	NBR (STD)	FPM (.0110)	EPDM (.0220)◆	STHT (.3400)	IPFE (.0770)
7CP6111CS, 7CP6111CCS, 7CP6111CSG1, 7CP6171CS, 7CP6171CSS	76387	76940	76258	76387	32130

ITEM (Included in Valve Kits)						DESCRIPTION	QTY
162	43248	43248	43248	43248	43248	Backup Ring, Valve Seat	3
163	43249	44383	46206	43249	701852	O-Ring, Valve Seat	3
164	44037	44037	44037	44037	44037	Seat	3
166	44038	44038	44038	44038	44038	Valve	3
167	44039	44039	44039	44039	44039	Spring	3
168	44564	44564	44564	44564	44564	Retainer, Spring	3
172	17617	11691	46207	17617	701853	O-Ring, Valve Plug	3

◆ Silicone oil/grease required

⚠ CAUTIONS AND WARNINGS

All high-pressure systems require a primary pressure regulating device (i.e. regulator, unloader) and a secondary pressure relief device (i.e. pop-off valve, relief valve). Failure to install such relief devices could result in personal injury or damage to pump or property. Cat Pumps does not assume any liability or responsibility for the operation of a customer's high-pressure system.

Read all CAUTIONS and WARNINGS before commencing service or operation of any high-pressure system. The CAUTIONS and WARNINGS are included in each Service Manual and with each Accessory Data sheet. CAUTIONS and WARNINGS can also be viewed online at www.catpumps.com/dynamic-literature/cautions-and-warnings or can be requested directly from Cat Pumps.

WARRANTY

View the Limited Warranty online at www.catpumps.com/literature/cat-pumps-limited-warranty