

# DATA SHEET

## DIRECT DRIVE PLUNGER PUMP



**Stainless Steel  
Model:**

**2SFQ42SEEL**

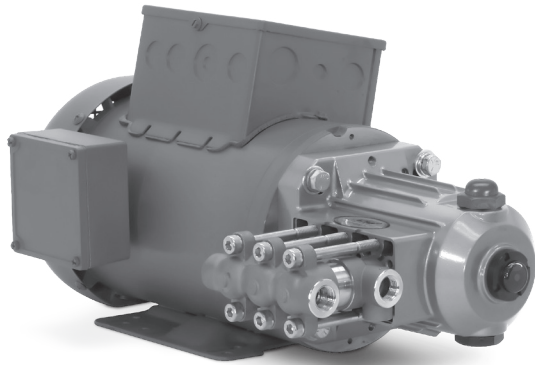

Motorized pump unit 2SFQ42SEELD251 Shown

### FEATURES

- Unique spring-loaded inlet valves and flow-through ceramic plungers provide a smooth, steady flow.
- Hollow shaft direct-drive configuration provides the smallest possible footprint for confined spaces.
- "Q" feature reduces pump noise for applications that require lower sound levels.
- Pump comes standard with NBR seals. Alternative seal materials are available for higher temperature or chemical compatibility.

### SPECIFICATIONS

	U.S. Measure	Metric Measure
Flow	4.2 gpm	15.9 lpm
Pressure Range	100–1200 psi	6.9–83 bar
Pump RPM	1725 rpm	1725 rpm
Inlet Pressure Range	Flooded to 60 psi	Flooded to 4.1 bar
Max. Liquid Temp. (NBR)	160° F	71° C

### Alternative seals available for higher temperatures up to 180° F

Bore	0.789"	20 mm
Stroke	0.402"	10.2 mm
Crankcase Capacity	10.1 oz	0.30 l
Inlet Port (1)	3/8" NPT(F)	3/8" NPT(F)
Discharge Ports (2)	3/8" NPT(F)	3/8" NPT(F)
Bypass Return Port (1)	1/4" NPT(F)	1/4" NPT(F)
Shaft Diameter	5/8"	15.9 mm
Weight (Pump Only)	8.9 lbs	4 kg
Dimensions (Pump Only)	6.8 x 8.7 x 5.2"	173 x 221 x 133 mm

### ALTERNATIVE SEAL CONFIGURATION

MATERIAL	SUFFIX CODE	MAXIMUM TEMPERATURE	
NBR	—	160° F	(71° C)
FPM	.0110	180° F	(82° C)
EPDM	.0220	160° F	(71° C)
IPFE	.0770	180° F	(82° C)

See **Tech Bulletin 002** for inlet conditions and RPM at high temperature.

### DETERMINING THE PUMP RPM

$$\frac{\text{Rated gpm}}{\text{Rated rpm}} = \frac{\text{Desired gpm}}{\text{Desired rpm}}$$

### DETERMINING THE REQUIRED HP

$$\text{hp (Electric Brake)} = \frac{\text{gpm} \times \text{psi}}{1460}$$

Refer to pump **Service Manual** for repair procedure and additional technical information.

# PARTS LIST

ITEM	PART NUMBER	MATL	DESCRIPTION	QTY
5	547445	S	Screw, HHC Sems (M6 X 14) (See Tech Bulletin 074)	3
8	547153	AL	Cover, Bearing	1
10	14041	NBR	O-Ring, Bearing Cover-70D	1
11	55337	NBR	Seal, Oil Crankshaft	1
15	14488	STL	Bearing, Ball, Inner	1
20	547046	TNM	Rod, Connecting	3
25	544694	CM	Crankshaft, 10.2 mm	1
26	12385	STL	Ring, Retaining, Bearing	1
27	15710	STL	Bearing, Ball, Outer	1
32	547961	RTP	Cap, Oil Filler with O-Ring	1
33	14179	NBR	O-Ring, Oil Filler Cap-70D	1
37	92241	PC	Gauge, Oil with Gasket-80D (See Tech Bulletin 074)	1
38	44428	NBR	Gasket, Flat, Oil Gauge-80D	1
48	44842	NY	Plug, Drain	1
49	14179	NBR	O-Ring, Drain Plug-70D	1
52	833820	S5SS	Pin, Guide (See Tech Bulletin 122)	1
53	833819	AL	Crankcase (See Tech Bulletin 122)	1
64	16948	CM	Pin, Crosshead	2
65	834203	SSTO	Rod, Plunger (See Tech Bulletin 124)	1
69	126259	STCP R	Washer, Oil Seal	3
70	25461	NBR	Seal, Oil Crankcase	3
90	831290	CC	Plunger, Ceramic (M20 x 18)	3
100	44869	PVDF	Retainer, Seal	3
106	547683	NBR	Seal, Low-Pressure with SS-Spring	3
110	833822	SS	Manifold, Inlet (See Tech Bulletin 122)	3
125	44649	SNG	Seal, High-Pressure, with SS-Support	3
134	833821	D	Valve, Inlet (See Tech Bulletin 122)	1
135	543689	SS	Spacer	3
136	543690	SS	Spring, Inlet Valve	3
137	88575	S	Washer, Conical (M6)	3
138	543692	SS	Nut (M6)	3
152	549539	NBR	O-Ring, Adapter, Spacer, Inner-70D	3
157	831289	SS	Adapter, Valve	3
159	† 26089	NBR	O-Ring, Adapter, Spacer, Outer-80D	3
164	544293	SS	Seat	3
166	833825	D	Valve (See Tech Bulletin 122)	3
167	543700	SS	Spring	3
168	44565	PVDF	Retainer, Spring	3
185	547705	SS	Manifold, Discharge	3
188	544701	S	Screw, HSH (M8 x 80) (See Tech Bulletin 074)	3
255	30517	STZP R	Assembly, Bolt Mount	1

**Bold print part numbers are unique to a particular pump model.**

R Components comply with RoHS Directive. † Production parts different from service parts.

For additional technical information see [www.catpumps.com/literature/tech-bulletins](http://www.catpumps.com/literature/tech-bulletins).

NOTE: Discard Key that may come standard with most motors and engines and use only the key included in Bolt kit.

MATERIAL CODES (Not Part of Part Number): AL=Aluminum CC=Ceramic CM=Chrome-Moly D=Acetal EPDM=Ethylene Propylene Diene Monomer

FPM=Fluorocarbon IPFE=I-Perfluoroelastomer NBR=Medium Nitrile (Buna-N) NY=Nylon PC=Poly Carbonate PVDF=Polyvinylidene Fluoride

RTP=Reinforced Composite S=304SS SNG=Special Blend (Buna) SS=316SS S5SS=440SS SSTO=316SS/Titanium Oxide ST=Special PTFE

STL=Steel ST4=Special PTFE 4 STCP=Steel/Chrome Plated STZP=Steel/ZincPlated TNM=Special High Strength

# EXPLODED VIEW

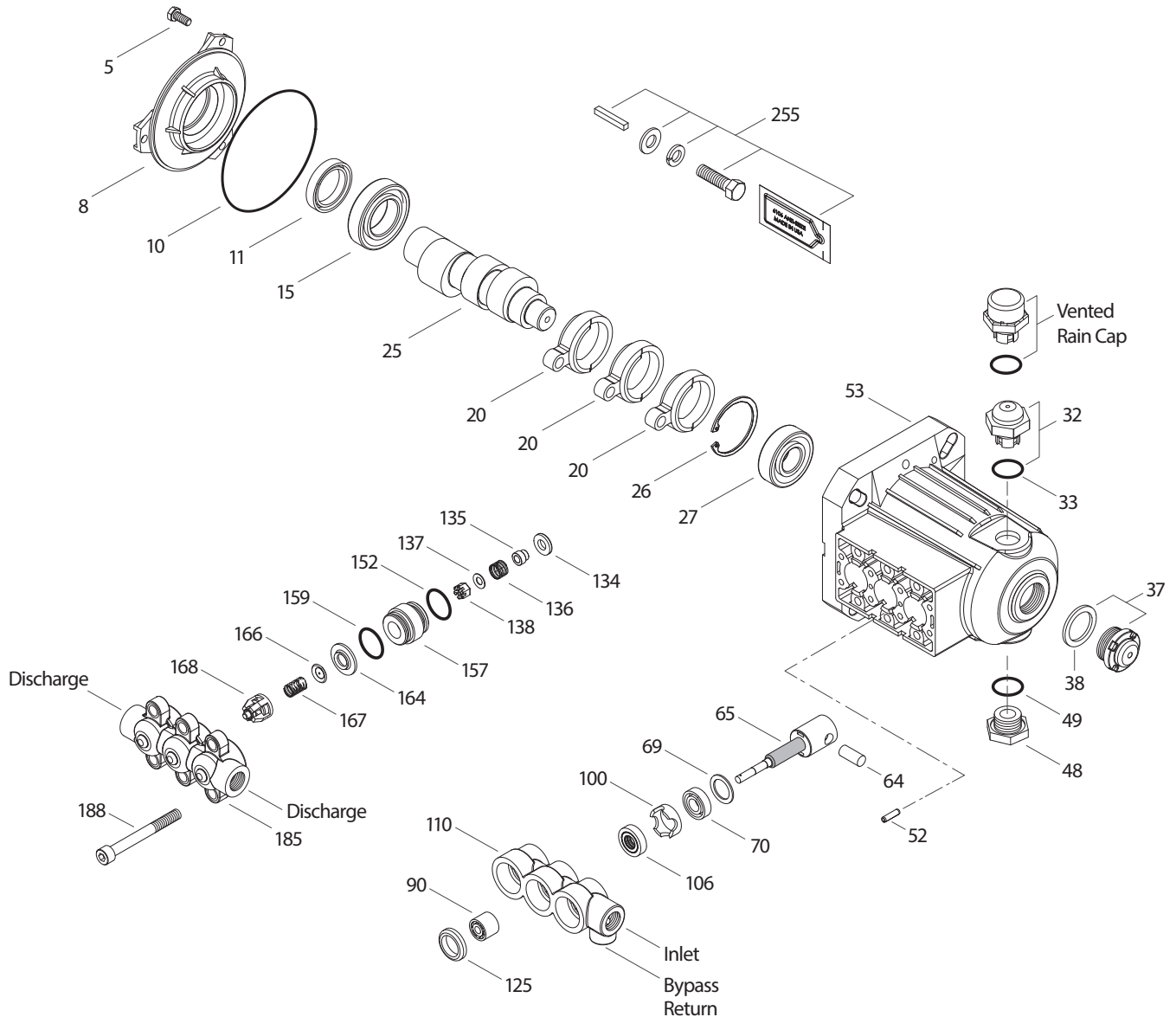

Models  
2SFQ42SEEL  
February 2022

## OPTIONAL PARTS AND ACCESSORIES

PART	DESCRIPTION	QTY
549726	Cap, Vented with O-Ring (Rain Cap)	1
80228	Screw, HH (M8 - 1.25 x 80 Full Thread) (See Tech Bulletin 055)	2
7501	Unloader, 3/8" Ports, 316 SS (Not Shown)	1
7501.100	Regulator, 3/8" Ports, 316 SS (Not Shown)	1
9960	Valve, Pop-Off, 1/4" Port, 316 SS (Not Shown)	1
990394	Kit, Oil Drain (Not Shown)	1

## SERVICE PARTS

PART	DESCRIPTION	QTY
<b>76265</b>	Seal Kit - Standard NBR	1
<b>76274</b>	Discharge Valve Kit - Standard NBR	1
<b>76278</b>	Inlet Valve Kit - Standard NBR	1
6139	Lubricant, Anti-Seize (8 oz) (See Tech Bulletin 095) (Fill to Specified Crankcase Capacity Prior to Start-up)	1
6107	Oil, Bottle (21 oz)	1

## SEAL KITS One (1) seal kit required per pump

**PUMP MODEL**      **NBR (STD)**      **FPM (.0110)**      **EPDM (.0220) ◆**      **IPFE (.0770)**

2SFQ42SEEL	<b>76265</b>	<b>76955</b>	<b>76996</b>	<b>76549</b>
------------	--------------	--------------	--------------	--------------

ITEM (Included in Seal Kits)					DESCRIPTION	QTY
106	547683	545192	546507	76443	Seal, Low-Pressure, with SS-Spring	3
125	44649	44936	46667	76395	Seal, High-Pressure, with SS-Support	3
152	549539	129977	129978	994831	O-Ring, Adapter Spacer, Inner	3
159	26089	11377	46647	703244	O-Ring, Adapter Spacer, Outer	3

◆ Silicone oil/grease required \*Review material codes for individual items (STG generally by be used as alternative)

## DISCHARGE VALVE KITS One (1) valve kit required per pump

**PUMP MODEL**      **NBR (STD)**      **FPM (.0110)**      **EPDM (.0220) ◆**      **IPFE (.0770)**

2SFQ42SEEL	<b>76274</b>	<b>76445</b>	<b>76446</b>	<b>76597</b>
------------	--------------	--------------	--------------	--------------

ITEM (Included in Valve Kits)					DESCRIPTION	QTY
152	549539	129977	129978	994831	O-Ring, Adapter Spacer, Inner	3
159	26089	11377	46647	703244	O-Ring, Adapter Spacer, Outer	3
164	544293	544293	544293	544293	Seat	3
166	833825 <sup>1</sup>	543669 <sup>2</sup>	543669 <sup>2</sup>	543669 <sup>2</sup>	Valve	3
167	543700	543700	543700	543700	Spring	3
168	44565	44565	44565	44565	Retainer, Spring	3

◆ Silicone oil/grease required

1= Acetal Material

2= 316SS Material

## INLET VALVE KITS One (1) valve kit required per pump

**PUMP MODEL**      **NBR (STD)**      **FPM (.0110)**      **EPDM (.0220) ◆**      **IPFE (.0770)**

2SFQ42SEEL	<b>76278</b>	<b>76465</b>	<b>76466</b>	<b>76587</b>
------------	--------------	--------------	--------------	--------------

ITEM (Included in Valve Kits)					DESCRIPTION	QTY
134	833821 <sup>1</sup>	831400 <sup>2</sup>	831400 <sup>2</sup>	831400 <sup>2</sup>	Valve, Inlet	3
135	543689	543689	543689	543689	Spacer	3
136	543690	543690	543690	543690	Spring	3
137	88575	88575	88575	88575	Washer, Conical	3
138	543692	543692	543692	543692	Nut	3
152	549539	129977	129978	994831	O-Ring, Adapter Spacer, Inner	3
159	26089	11377	46647	703244	O-Ring, Adapter Spacer, Outer	3

◆ Silicone oil/grease required

1= Acetal Material

2= 316SS Material

MODEL	8105	8175	8110	8115	8120	8125/8125W
Dimension A	15.9	15.9	17.1	19.3	19.3	19.3
Dimension B	9.0	9.0	10.2	12.4	12.4	12.4
Dimension C	8.2	8.2	8.2	9.7	9.7	9.7
Dimension D	9.1	9.1	9.1	9.7	9.7	9.7

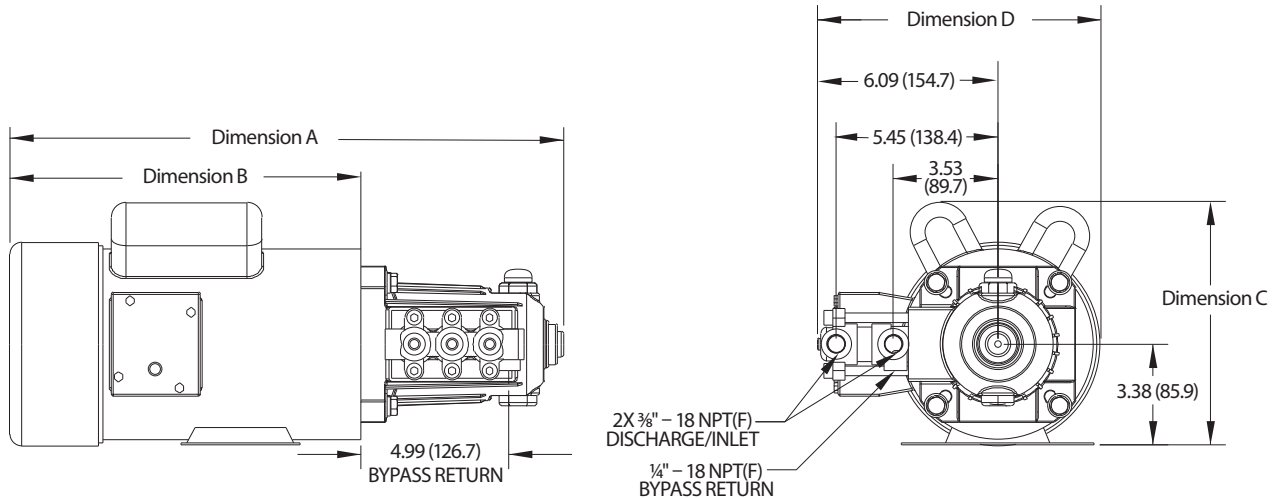

## MOTOR SPECIFICATIONS

MODEL	8105	8175	8110	8115	8120	8125/8125W
HorsePower	0.5	0.75	1.0	1.5	2.0	2.5
Phase	Single	Single	Single	Single	Single	Single
RPM	1750	1745	1750	1750	1750	1750
Frame Size	56C TEFC	56C TEFC	56C TEFC	56HC TEFC	56HC TEFC	56HC TEFC
Shaft Diameter	5/8"	5/8"	5/8"	5/8"	5/8"	5/8"
Maximum Volts	115/208-230	115/208-230	115/208-230	115/208-230	115/208-230	115/208-230
Full Load Amps	7.4/3.6-3.7	10.6/5.2-5.3	14/6.8-7.0	13.8/7.63-6.90	17.2/9.53-8.62	20.8/10.4
Hertz	60	60	60	60/50	60/50	60/50
Service Factor	1.15	1.15	1.15	1.85	1.40	1.15
Max. Ambient Temp.	104° F	104° F	104° F	104° F	104° F	104° F
Capacitor Start	Yes	Yes	Yes	Yes	Yes	Yes
Thermal Overload-Manual Reset	No	Yes	No	No	No	No
Weight (lbs.)	25	28	34	53.8	53.8	53.8

### NOTES:

1. Motor start-up Amps may vary, then settle within Full Load Amps rating after initial run time.
2. Refer to Tech Bulletin 136 for complete specifications for 50 Hz versions of Models 8115 and 8120.
3. Before mounting pump on motor, apply an antiseize lubricant (or PN 6106) to pump shaft.
4. Refer to Tech Bulletin 055 for instructions on removing pump from electric motor.
5. For electric motor warranty consideration, contact motor manufacturer's local Authorized Service Center.

### ⚠ CAUTIONS AND WARNINGS

All high-pressure systems require a primary pressure regulating device (i.e. regulator, unloader) and a secondary pressure relief device (i.e. pop-off valve, relief valve). Failure to install such relief devices could result in personal injury or damage to pump or property. Cat Pumps does not assume any liability or responsibility for the operation of a customer's high-pressure system. Read all CAUTIONS and WARNINGS before commencing service or operation of any high-pressure system. The CAUTIONS and WARNINGS are included in each Service Manual and with each Accessory Data sheet. CAUTIONS and WARNINGS can also be viewed online at [www.catpumps.com/dynamic-literature/cautions-and-warnings](http://www.catpumps.com/dynamic-literature/cautions-and-warnings) or can be requested directly from Cat Pumps.

### WARRANTY

View the Limited Warranty online at [www.catpumps.com/literature/cat-pumps-limited-warranty](http://www.catpumps.com/literature/cat-pumps-limited-warranty)