

DATA SHEET

DIRECT DRIVE PLUNGER PUMPS



Brass Models: **5SP30ELR, 5SP35ELR, 5SP40ELR**

See page 8 for complete pump model number selection.

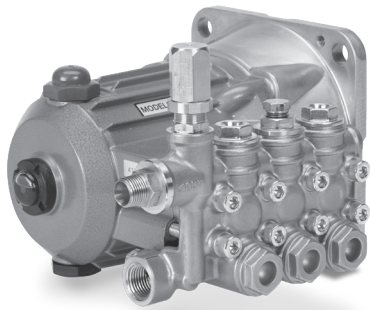

Model 5SP35ELR Shown

FEATURES

- Fits standard 182/184TC face electric motors.
- Specially-formulated high-pressure seals and concentric solid ceramic plungers provides true wear surface and extended seal life.
- Multiple accessory ports provide plumbing flexibility.
- Compact, direct mounting reduces space requirements.
- Integral pressure regulator or unloader with built-in bypass ensures system pressure control and pump protection.
- Includes crankcase oil.

COMMON SPECIFICATIONS

	U.S.	Metric
Pump RPM	1750 rpm	1750 rpm
Inlet Pressure Range	Flooded to 60 psi	Flooded to 4.1 bar
Standard Liquid Temperature	140° F	60° C
Crankcase Capacity	13.5 oz	0.4 l
Inlet Port	½" NPT(F)	½" NPT(F)
Accessory Ports (3)	¼" NPT(F)	¼" NPT(F)
Discharge Port	⅜" NPT(M)	⅜" NPT(M)
Shaft Diameter	1⅝"	28.5 mm
Weight	13.2 lbs	6.0 kg
Dimensions	9.53 x 9.73 x 7.13"	242 x 234.5 x 181 mm

Above 130°F call Cat Pumps for inlet conditions and elastomer recommendations.

SPECIFICATIONS

	U.S. Measure	Metric Measure
5SP30ELR		
Flow	3.0 gpm	11.4 lpm
Pressure Range	100–3000 psi	6.9–207 bar
Bore	0.630"	16 mm
Stroke	0.433"	11 mm
5SP35ELR		
Flow	3.5 gpm	13.2 lpm
Pressure Range	100–2500 psi	6.9–172 bar
Bore	0.708"	18 mm
Stroke	0.433"	11 mm
5SP40ELR		
Flow	4.0 gpm	15.1 lpm
Pressure Range	100–2000 psi	6.9–138 bar
Bore	0.787"	20 mm
Stroke	0.397"	10.1 mm

ELECTRIC HORSEPOWER REQUIREMENTS

MODELS	FLOW		PRESSURE						PUMP RPM
	GPM	LPM	PSI	BAR	PSI	BAR	PSI	BAR	
			2000	138	2500	172	3000	207	
			Horsepower						
5SP30ELR	3.0	11.4	4.1 hp		5.1 hp		6.2 hp		1750
5SP35ELR	3.5	13.2	4.8 hp		6.0 hp		NA		1750
5SP40ELR	4.0	15.1	5.5 hp		NA		NA		1750

$$\text{DETERMINING THE PUMP RPM} \quad \frac{\text{Rated gpm}}{\text{Rated rpm}} = \frac{\text{Desired gpm}}{\text{Desired rpm}}$$

$$\text{DETERMINING THE REQUIRED HP} \quad \frac{\text{hp (Electric Brake)}}{\text{gpm} \times \text{psi}} = \frac{\text{Desired gpm} \times \text{psi}}{1460}$$

Refer to pump **Service Manual** for repair procedure and additional technical information.

PARTS LIST

ITEM	P/N	MATL	P/N	MATL	P/N	MATL	DESCRIPTION	QTY
	5SP30ELR		5SP35ELR		5SP40ELR			
5	127285	STCP R	127285	STCP R	127285	STCP R	Screw, HH Sems (M8 x 25) (See Tech Bulletin 074)	4
8	134123	AL	134123	AL	134123	AL	Cover, Bearing	1
10	14043	NBR	14043	NBR	14043	NBR	O-Ring, Bearing Cover	1
11	134797	NBR	134797	NBR	134797	NBR	Seal, Oil, Crankshaft	1
15	134331	STL	134331	STL	134331	STL	Bearing, Ball, Inner	1
20	49364	TNM	49364	TNM	49364	TNM	Rod, Connecting	3
24	549608	LDPE	549608	LDPE	549608	LDPE	Plug, Oil Cap	1
25	134345	CM	134345	CM	—	—	Crankshaft, 1 1/8", (11 mm)	1
	—	—	—	—	134329	CM	Crankshaft, 1 1/8", (10.1 mm)	1
27	49363	STL	49363	STL	49363	STL	Bearing, Ball, Outer	1
31	549726	—	549726	—	549726	—	Cap, Vented with O-Ring (Rain Cap) (Not Shown)	1
32	547961	RTP	547961	RTP	547961	RTP	Cap, Oil Filler with O-Ring	1
33	14179	NBR	14179	NBR	14179	NBR	O-Ring, Filler Cap-70D	1
37	92241	PC	92241	PC	92241	PC	Gauge, Oil Bubble with Gasket-80D (See Tech Bulletin 074)	1
38	44428	NBR	44428	NBR	44428	NBR	Gasket, Flat, Oil Gauge-80D	1
48	44842	NY	44842	NY	44842	NY	Plug, Drain	1
49	14179	NBR	14179	NBR	14179	NBR	O-Ring, Drain Plug-70D	1
53	49352	AL	49352	AL	49352	AL	Crankcase	1
64	49366	CM	49366	CM	49366	CM	Pin, Crosshead	3
65	49368	BB	49368	BB	49368	BB	Rod, Plunger	3
70	47215	NBR	47215	NBR	47215	NBR	Seal, Oil Crankcase	3
75	49370	S	49370	S	49370	S	Slinger, Barrier	3
90	134351	CC	—	—	—	—	Plunger (M16 x 30)	3
	—	—	134346	CC	—	—	Plunger (M18 x 33)	3
	—	—	—	—	134333	CC	Plunger (M20 x 33)	3
98	46730	NBR	46730	NBR	46730	NBR	Washer, Seal-90D	3
99	49369	S	49369	S	49369	S	Retainer, Plunger (See Tech Bulletin 074)	3
100	49371	NY	49371	NY	49371	NY	Retainer, Seal	3
106	48222	NBR	43243	NBR	43305	NBR	Seal, Low-Pressure with S-Spring	3
120	134352	BB	134347	BB	134334	BB	Case, Seal	3
121	13977	NBR	13977	NBR	13978	NBR	O-Ring, Seal Case-70D	3
125	547157	SNG	—	—	—	—	Seal, High-Pressure	3
	—	—	43245	SNG	—	—	Seal, High-Pressure with S-Support	3
	—	—	—	—	43307	SNG	Seal, High-Pressure with S-Support	3
160	14181	NBR	14181	NBR	14181	NBR	O-Ring, Valve Seat, Inlet-70D	3
161	45790	S	45790	S	45790	S	Seat, Inlet	3
163	17428	NBR	17428	NBR	17428	NBR	O-Ring, Seat, Discharge-80D	3
164	547077	S	547077	S	547077	S	Seat, Discharge	3
165	43723	S	43723	S	43723	S	Valve, Inlet	3
166	547098	S	547098	S	547098	S	Valve, Discharge	3
167	43750	S	43750	S	43750	S	Spring, Inlet	3
168	46583	NY	46583	NY	46583	NY	Retainer, Spring, Inlet	3
169	49764	PVDF	49764	PVDF	49764	PVDF	Retainer, Spring, Discharge	3
170	134579	S	134579	S	134579	S	Spring, Discharge	3
171	17615	NBR	17615	NBR	17615	NBR	O-Ring, Valve Plug, Inlet-80D	3
172	142807	NBR	142807	NBR	142807	NBR	O-Ring, Valve Plug, Discharge-90D	3
173	46756	BB	46756	BB	46756	BB	Plug, Valve, Inlet	3
174	547104	BB	547104	BB	547104	BB	Plug, Valve, Discharge, with O-Ring (See Tech Bulletin 074)	2
175	101556	BB	101556	BB	101556	BB	Plug (1/4" NPT[M])	2
180	134670	BB	134670	BB	134670	BB	Plug, Valve (1/4" NPT[F]) Threaded Port with O-Ring (See Tech Bulletin 074)	1
185	134128	BB	134127	BB	134126	BB	Head, Manifold with Integral Unloader	1
188	134340	STCP R	134340	STCP R	134340	STCP R	Screw, HSH (M6 x 55) (See Tech Bulletin 074)	8
252	126761	STCP R	126761	STCP R	126761	STCP R	Screw, Set (M5 x 8)	1
253	134760	STL	134760	STL	134760	STL	Key (1/4" x 1/4" x 45)	1
255	134928	STZP R	134928	STZP R	134928	STZP R	Assembly, Bolt Mount (Includes: 252, 253)	1
300	76968	NBR	76503	NBR	33628	NBR	Kit, Seal (Includes: 98, 106, 121, 125)	1
310	76302	NBR	76302	NBR	76302	NBR	Kit, Valve, Inlet (Includes: 160, 161, 165, 167, 168, 171)	1
	76303	NBR	76303	NBR	76303	NBR	Kit, Valve, Discharge (Includes: 163, 164, 166, 169, 170, 172)	1
400	NA	—	NA	—	NA	—	Integral Unloader (See Individual Parts List)	1
469	134348	BB	134348	BB	—	—	Injector, Chemical (2.0 orifice)	1
	—	—	—	—	134338	BB	Injector, Chemical (2.1 orifice)	1

Bold part numbers are unique to a particular pump model. Italics are optional items.

R Components comply with RoHS Directive. For additional technical information see www.catpumps.com/literature/tech-bulletins.

MATERIAL CODES (Not Part of Part Number): AL=Aluminum BB=Brass CC=Ceramic CM=Chrome-moly D=Acetal LDPE=Low Density Polyethylene
NBR=Medium Nitrile (Buna-N) NY=Nylon PC=Poly Carbonate PVDF=Polyvinylidene Fluoride RTP=Reinforced Composite S=304SS SNG=Special Blend (Buna)
STL=Steel STCP=Steel/Chrome Plated STZP=Steel/Zinc Plated TNM=Special High Strength

NOTE: Discard Key which may come standard with most motors and **use only the key included in this kit.**

EXPLODED VIEW

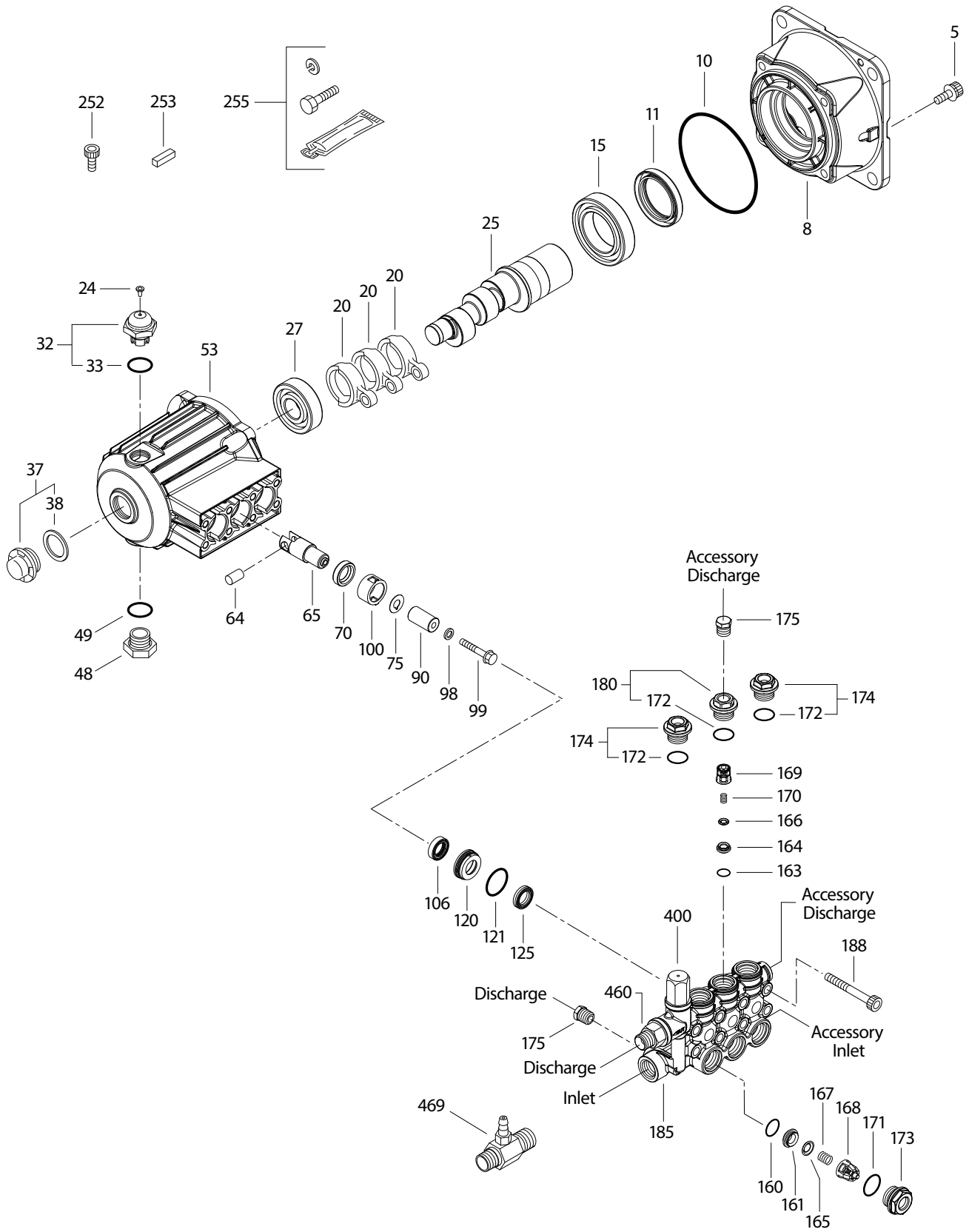

INTEGRAL REGULATOR/UNLOADER

EXPLODED VIEW

SPECIFICATIONS

	U.S.	Metric
Flow	4.0 gpm	15.1 lpm
PSI Range	100–3000 psi	6.9–207 bar
Inlet Port	½" NPT(F)	½" NPT(F)
Discharge Port	¾" NPT(M)	¾" NPT(M)

PARTS LIST

ITEM	PN	MATL	DESCRIPTION	QTY
402	547798	BB	Cap, Adjusting	1
403	548671	BB	Nut, Locking (M18 x 1)	1
404	548675	STL	Screw, Set (M4 x 4)	1
408	32094	STZP R	Spring, Pressure	1
410	549352	STCP R	Retainer, Spring	1
412	45694	S	Stem, Piston (M5)	1
414	20184	PTFE	Backup Ring, Piston Stem	1
415	14190	NBR	O-Ring, Piston Stem–70D	1
418	—	—	Assembly, Piston (Included In Repair Kit)	1
423	46249	BB	Retainer, Valve	1
424	13966	NBR	O-Ring, Valve Retainer (Outer)–70D	1
425	547799	BB	Retainer, Piston	1
426	46250	S	Washer	1
428	26133	NBR	O-Ring, Piston Retainer–80D	1
429	17399	NBR	O-Ring, Valve Retainer (Inner)–70D	1
435	547800	S	Valve	1
436	49664	S	Seat (Models: 5SP30ELR, 5SP35ELR)	1
	548075	S	Seat (Model: 5SP40ELR)	1
437	13963	NBR	O-Ring, Seat–70D	1
443	134009	D	Valve, Check	1
444	117275	S	Spring	1
446	26133	NBR	O-Ring, Body–80D	1
460	134757	BB	Fitting, Discharge (¾" NPT[M]) with O-Ring	1
468	76499	NBR	Kit, O-Ring (Includes: 414, 415, 424, 428, 429, 437, 446)	1
469	134348	BB	Injector, Chemical Fixed (2.0 mm) (Models: 5SP30ELR, 5SP35ELR)	1
	134338	BB	Injector, Chemical Fixed (2.1 mm) (Model: 5SP40ELR)	1
470	76179	NBR	Kit, Repair (Includes: 418, 425, 428, 436, 437) (Models: 5SP30ELR, 5SP35ELR)	1
	76505	NBR	Kit, Repair (Includes: 418, 425, 428, 436, 437) (Model: 5SP40ELR)	1
471	76506	NBR	*Kit, Check Valve (Includes: 443, 444, 446)	1

*76506 Kit Changes Regulator to Unloader

Bold part numbers are unique to a particular pump model.

Italics are optional items. R Components comply with RoHS Directive.

MATERIAL CODES (Not Part of Part Number): BB=Brass D=Acetal

NBR=Medium Nitrile (Buna-N) PTFE=Pure Polytetrafluoroethylene

S=304SS STCP=Steel/Chrome Plated STL=Steel

STZP=Steel/Zinc Plated

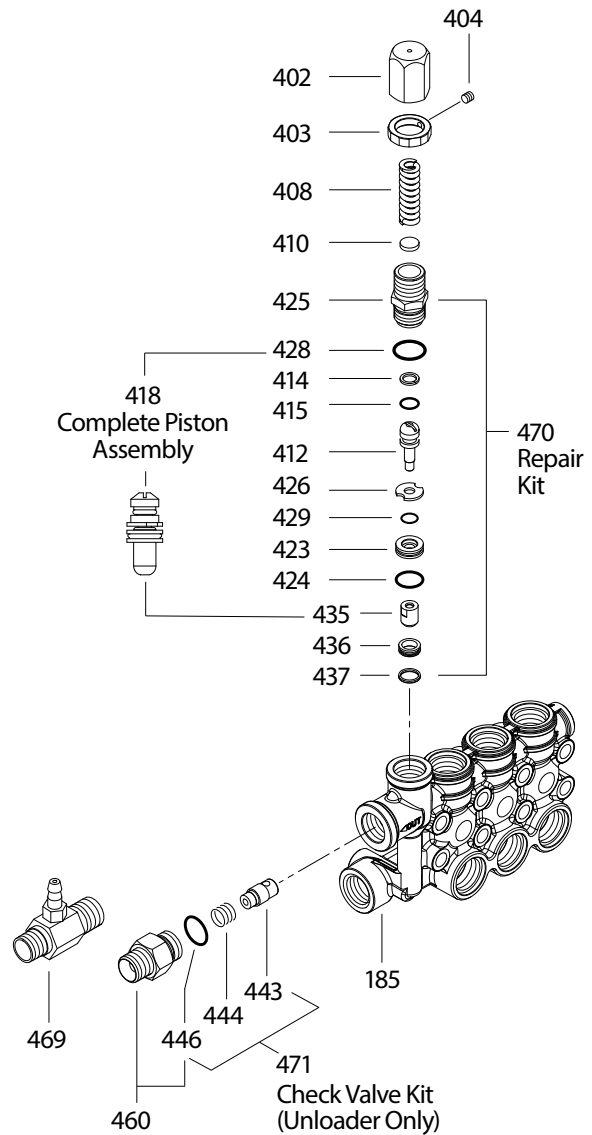

MODELS 134348, 134338 FIXED CHEMICAL INJECTOR

EXPLODED VIEW

SPECIFICATIONS	U.S.	Metric
GPM	3.1 gpm	11.7 lpm
Nozzle Orifice (134348)	2.0 mm	2.0 mm
Nozzle Orifice (134338)	2.1 mm	2.1 mm
Hose Barb	¼"	¼"
Inlet Port	M18 x 1.0	M18 x 1.0
Discharge Port	¾" NPT(M)	¾" NPT(M)
Weight	5.3 oz	0.15 kg
Dimensions	2 x 1 x 1.75	52 x 25 x 45 mm

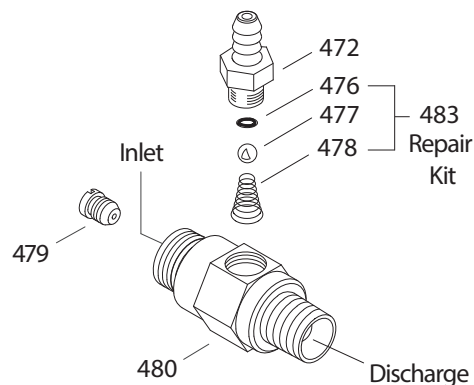

PARTS LIST

ITEM	PN	MATL	DESCRIPTION	QTY
472	—	BB	Barb	1
476	—	NBR	O-Ring, Barb-70D	1
477	—	S	Ball	1
478	—	S	Spring	1
479	—	S	Orifice	1
480	—	BB	Body	1
483	—	NBR	Kit, Repair (Includes: 476, 477, 478)	1

MATERIAL CODES (Not Part of Part Number):
 BB=Brass NBR=Medium Nitrile (Buna-N) S=304SS

REGULATING DEVICE

An integral regulator or unloader with built-in bypass is part of the discharge manifold to provide system pressure regulation and pump protection. (See back page for proper model identifications.)

OPERATION:

Pump should be purged of air before commencing with operation. Liquid must flow through the pump without discharge restriction to assure full system pressure is reached. Install a pressure gauge close to the manifold head of the pump to assist in setting system pressure and to periodically monitor system pressure. Setting and adjusting the regulator or unloader pressure must be done with the system turned on. Start the system with the regulator or unloader backed off to the lowest pressure setting (counterclockwise direction). Squeeze the trigger and read the pressure on the gauge at the pump. Do not read pressure at the gun or nozzle.

If more pressure is desired, release the trigger, turn adjusting cap one quarter turn in a clockwise direction. Squeeze the trigger and read the pressure. Repeat this process until the desired system pressure is reached.

NOTE: Pressure is not set at the factory.

SERVICE:

The regulator or unloader should be serviced on the same schedule as the seals in the pump. Refer to 5SP service manual for start-up, servicing of seals and valves, torque requirements and diagnosis and maintenance chart.

PERFORMANCE CHART

Orifice Size	Maximum Injecting Pressure	Minimum Chemical Draw	Pressure Drop Across Orifice
1.8 mm	100 psi	52 oz/min	100 psi

NOTE: Optimum performance of Chemical Injector occurs with a 35 ft. high-pressure hose with a minimum ¾" ID. The type of hose, extended lengths, reduced ID and fittings may create additional backpressure above the maximum injecting pressure rating of the injector and prevent it from drawing chemicals.

ELECTRIC MOTOR SPECIFICATIONS

Model 999839

Horsepower	3.0
Shaft Diameter	1 $\frac{1}{8}$ "
Maximum Volts	208–230/460
Full Load Amps	14.7–13.6/6.8
RPM	1760
Weight	99 lbs
Phase	Single
Frame Size	184TC TEFC
Service Factor	1.15

Model 999809

Horsepower	3.0
Shaft Diameter	1 $\frac{1}{8}$ "
Maximum Volts	208–230/460
Full Load Amps	8.4–7.6/3.8
RPM	1760
Weight	100 lbs
Phase	Three
Frame Size	182/184TC TEFC
Service Factor	1.15**

** Service Factor at 208V = 1.00

Model 997634

Horsepower	5.0
Shaft Diameter	1 $\frac{1}{8}$ "
Maximum Volts	208–230/460
Full Load Amps	22.5–21.4/10.7
RPM	1760
Weight	113 lbs
Phase	Single
Frame Size	184TC TEFC
Service Factor	1.15

Model 996543

Horsepower	5.0
Shaft Diameter	1 $\frac{1}{8}$ "
Maximum Volts	208–230/380/460
Full Load Amps	14.3–12.9/6.45
RPM	1725
Weight	104 lbs
Phase	Three
Frame Size	184TC TEFC
Service Factor	1.25**

** Service Factor at 208V = 1.15

Model 998517

Horsepower	7.5
Shaft Diameter	1 $\frac{1}{8}$ "
Maximum Volts	208–230/460
Full Load Amps	32.0–30.6/15.3
RPM	1725
Weight	180 lbs
Phase	Single
Frame Size	213/215TCZ* TEFC
Service Factor	1.15**

* Frame size - 213/215TC with 184C Face

** Service Factor at 208V = 1.00

Model 999800

Horsepower	7.5
Shaft Diameter	1 $\frac{1}{8}$ "
Maximum Volts	208–230/380/460
Full Load Amps	19.9–18.4/9.18
RPM	1750
Weight	168 lbs
Phase	Three
Frame Size	213/215TCZ* TEFC
Service Factor	1.25**

* Frame size - 213/215TC with 184C Face

** Service Factor at 208V = 1.15

Common Motor Specifications

Max. Ambient Temperature	104° F
Hertz	60 Hz
Capacitor Start	Yes

Note: Motor start-up amps may vary, then settle within full load amps rating after initial run in time.

Before mounting pump on motor, apply PN 6106 Antiseize Lubricant to pump shaft.

Refer to Tech Bulletin 055 for instructions on removing pump from electric motor.

MOTOR DIMENSIONS

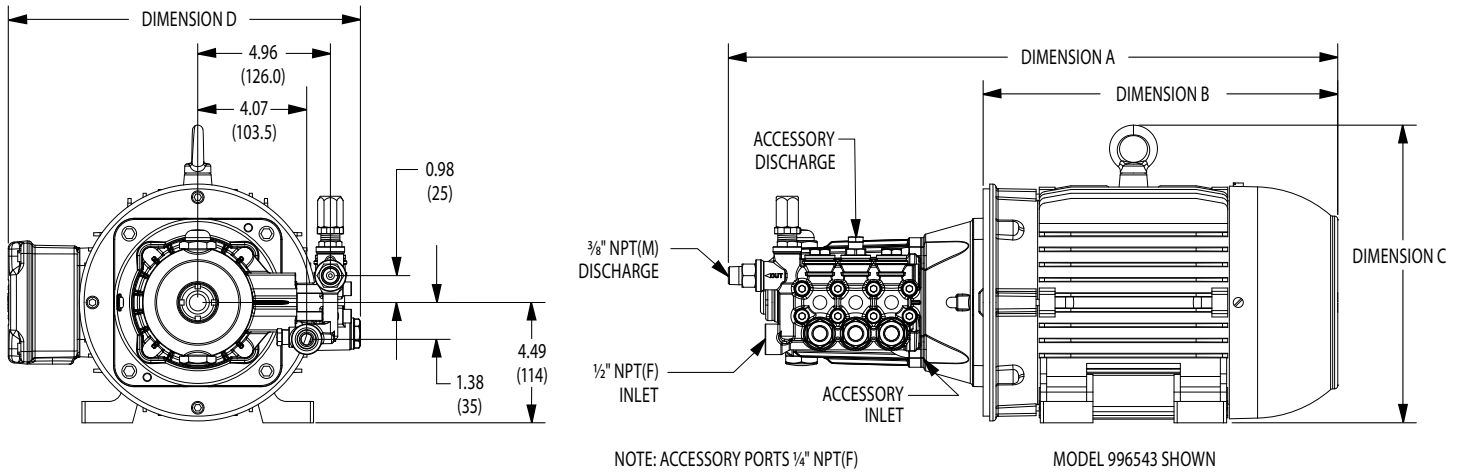

MODEL	999809	999839	997634	996543	999800	998517
Dimension A	22.79	23.79	22.79	22.79	25.91	26.35
Dimension B	13.26	14.26	13.26	13.26	16.38	16.82
Dimension C	11.11	9.15	11.11	11.11	12.61	9.15
Dimension D	13.59	12.20	15.80	13.17	14.73	14.60

ELECTRIC HORSEPOWER REQUIREMENTS

FLOW		PRESSURE						PUMP RPM
GPM	LPM	PSI	BAR	PSI	BAR	PSI	BAR	
		2000	138	2500	172	3000	207	
		Horsepower						
3.0	11.4	4.1 hp		5.1 hp		6.2 hp		1750
3.5	13.2	4.8 hp		6.0 hp		6.2 hp		1750
4.0	15.1	5.5 hp		NA		NA		1750

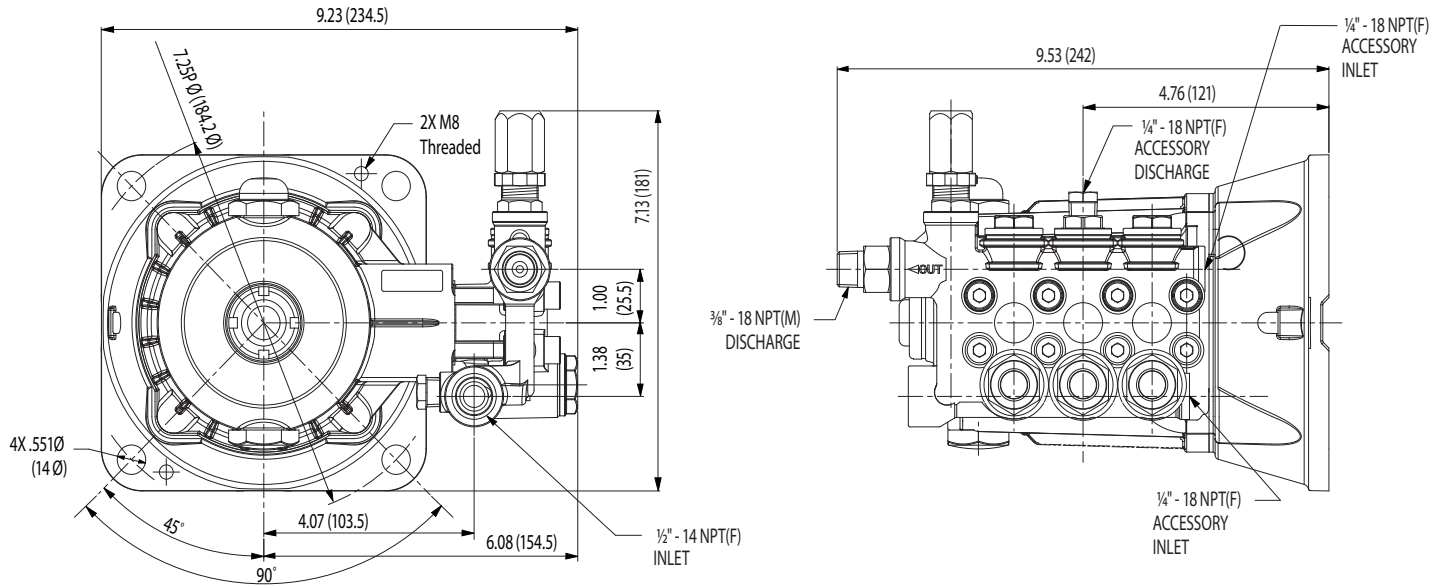

Base Models 5SP30ELR, 5SP35ELR, 5SP40ELR

5SP Pump Series Selection Chart

Pump Series							Pump Flow/RPM	
5	S	P					gpm	rpm
			3	0			3.0	1750
			3	5			3.5	1750
			4	0			4.0	1750
					EL		Electric, 1 1/8" Hollow Shaft	
						R	Regulating Device = Regulator	
						U	Regulating Device = Unloader	
						I	Fixed Chemical Injector	
							F	Inlet Garden Hose Fitting

Examples:

5SP30ELR = 3.0 gpm (1750 rpm), Regulator, Standard Inlet (1/2" NPT[F])

5SP35EUIF = 3.5 gpm (1750 rpm), Unloader, Chemical Injector, Garden Hose Inlet Fitting

CAUTIONS AND WARNINGS

All high-pressure systems require a primary pressure regulating device (e.g. regulator, unloader) and a secondary pressure relief device (e.g. pop-off valve, relief valve). Failure to install such relief devices could result in personal injury or damage to pump or property. Cat Pumps does not assume any liability or responsibility for the operation of a customer's high-pressure system. Read all CAUTIONS and WARNINGS before commencing service or operation of any high-pressure system. The CAUTIONS and WARNINGS are included in each Service Manual and with each Accessory Data sheet. CAUTIONS and WARNINGS can also be viewed online at www.catpumps.com/dynamic-literature/cautions-and-warnings or can be requested directly from Cat Pumps.

WARRANTY

View the Limited Warranty online at www.catpumps.com/literature/cat-pumps-limited-warranty