

TECH BULLETIN 036



How to Identify Your Pump — Cylinder and Plunger Reference Chart

Pumps manufactured by Cat Pumps should have a label clearly identifying the model number. If this label is not visible or has worn off, you can still identify your pump. On piston pumps, remove and measure one of the cylinders. On plunger pumps, you can remove and measure a ceramic plunger. See photos below for examples of the two different pump styles.

Page 2 has charts that list cylinder dimensions and crankshaft identification stamp numbers for current and obsolete piston pumps. Pages 3 and 4 cover ceramic plunger dimensions and crankshaft identification stamp numbers for current and obsolete ceramic plunger pumps. The final two pages list conversion model numbering and how to interpret these numbers.

Please note that the serial number stamped into the lower side of the crankcase or next to the mounting flange does not identify your pump model. The serial number does denote the date of production, however. See page 5 for more information regarding serial numbers.

Piston Pump

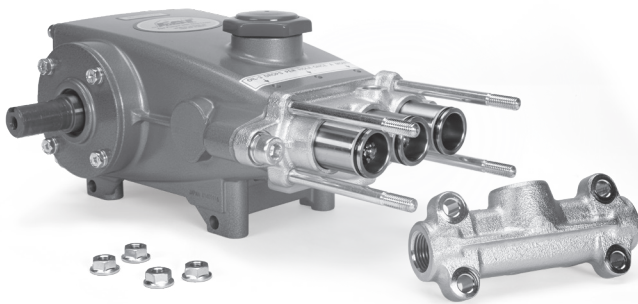

Plunger Pump

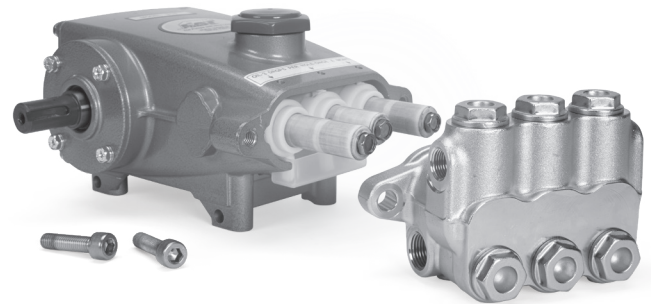

Crankshaft Identification Stamp Location

Solid Shaft Pumps

Includes all piston and plunger pumps, except 25 Frame and larger, where only 1 stroke option is used.



Hollow Shaft Pumps

1CX, 1DX, 2DX, 2SF, 2SFQ, 2SFX, 3DNX, 3DX, 3SP, 3SPX, 4DNX, 4DX, 4HP, 4SF, 4SPX, 5DX, 5SP, 6DX, 66DX, 67DX Series Pumps

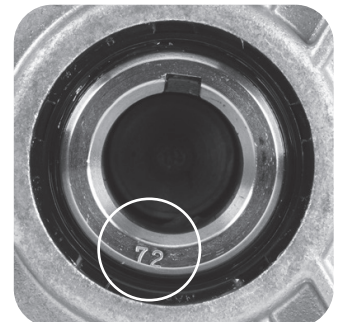

Piston Pumps

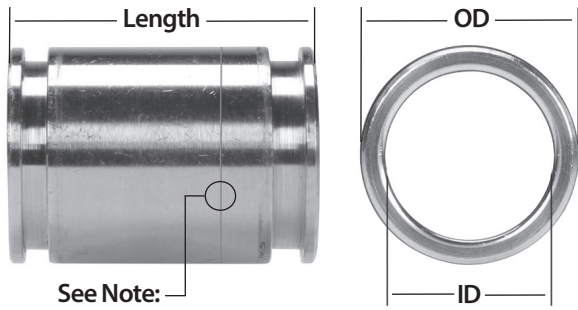

1. Remove pump discharge manifold to access cylinder.
2. Measure the length of cylinder, inside diameter (ID) and outside diameter (OD) of cylinder as shown.
3. Identify the stroke of the crankshaft. The stroke is stamped (mm) on the end of the crankshaft.
4. With information from steps 2 and 3, use the Cylinder Dimensional Reference Chart to identify piston pump.

NOTE: Models 333, 430, 623, 820, 1010 can be identified without removing the discharge manifold by looking for the machined groove on the discharge end of cylinder.

Model 333 has one machined groove
Model 430 has no machined groove

Model 623 has one machined groove
Model 820 has two machined grooves

Model 1010 has no machined groove

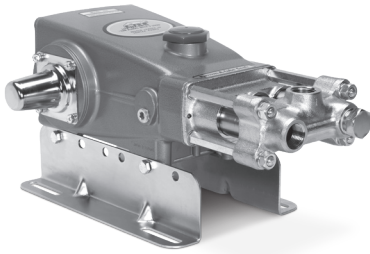

Piston Pumps – Cylinder Dimensional Reference Chart

MODEL	CYLINDER PART NUMBER	LENGTH Inches	LENGTH mm	ID Inches	ID mm	OD Inches	OD mm	CRANKSHAFT ID STAMP
280/281	26112	1.181	30	0.787	20	1.024	26	10
290/291	101802	1.378	35	0.787	20	1.024	26	13
323	43768	1.575	40	0.866	22	1.142	29	18
333/331	25660	1.575	40	0.709	18	1.024	26	20.5
430/431	24285	1.575	40	0.787	20	1.024	26	20.5
820/821	28340	1.969	50	0.984	25	1.417	36	—
1010/1011	28341	1.969	50	1.122	28.5	1.417	36	—
623/621	28342	1.969	50	0.787	20	1.417	36	—
390	44288	2.205	56	1.260	32	1.398	35.5	18
2520/2520C	27844	2.559	65	1.496	38	1.850	47	—
6020/6021	29466	4.409	112	2.205	56	2.559	65	—
6040/6041	43204	4.409	112	1.811	46	2.559	65	—

Obsolete Piston Pumps – Cylinder Dimensional Reference Chart

MODEL	PART NUMBER	LENGTH Inches	LENGTH mm	ID Inches	ID mm	OD Inches	OD mm	CRANKSHAFT ID STAMP
284	27877	1.319	33.5	0.787	20	1.024	26	10
410	24285	1.575	40	0.787	20	1.024	26	20.5
420	24285	1.575	40	0.787	20	1.024	26	20.5
260	24285	1.575	40	0.787	20	1.063	27	—
300	25660	1.575	40	0.709	18	1.024	26	—
330	25660	1.575	40	0.709	18	1.024	26	20.5
520	28763	1.969	50	0.709	18	1.417	36	—
400	22161	2.047	52	0.787	20	1.024	26	20.5
500	21984	2.047	52	0.787	20	1.024	26	—
1020/1021	27823	2.559	65	0.984	25	1.850	47	—
1520/1521	27817	2.559	65	1.122	28.5	1.850	47	—
2020/2021	28533	2.559	65	1.260	32	1.850	47	—
2521	27844	2.559	65	1.496	38	1.850	47	—
1000	20253	2.559	65	1.122	28.5	1.260	32	—
524	43131	2.579	65.5	1.020	25.9	1.496	38	—
1024	28673	2.598	66	1.102	28	1.772	45	—
1044	29080	2.677	68	1.339	34	1.772	45	—
624	43264	3.071	78	0.945	24	1.260	32	—
2500	13632	3.346	85	1.500	38.1	1.677	42.6	—
6024	43118	6.496	165	1.500	38	2.756	70	—
6044	43119	6.496	165	1.850	47	2.756	70	—

Note: For configurations with multiple pump options, see Pump Model Number Breakdown.

Plunger Pumps

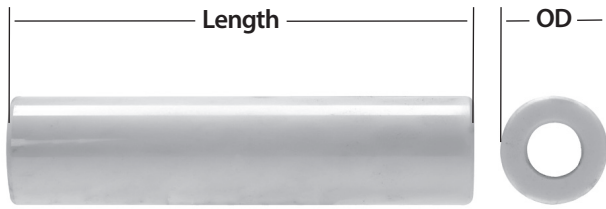

1. Remove pump manifold(s) to access ceramic plunger.
2. Measure the length of ceramic plunger and outside diameter as shown.
3. Identify the stroke of the crankshaft. The stroke is stamped (mm) on the end of the crankshaft for both hollow shaft and solid shaft models.
4. With information from steps 2 and 3, use the Ceramic Dimensional Reference Chart to identify plunger pump.

NOTE: If you have a hollow shaft pump, you will need to remove the pump from engine/motor to identify crankshaft identification stamp.

Plunger Pumps – Ceramic Dimensional Reference Chart

MODEL	CERAMIC PN	LENGTH Inches	LENGTH mm	OD Inches	OD mm	CRANKSHAFT ID STAMP
2SF10ES	45847	0.551	14.0	0.709	18	18
2SF20ES/2SFX20ES	45847	0.551	14.0	0.709	18	31
2SF22ES	45847	0.551	14.0	0.709	18	335
2SF30ES/2SFX30ES	45847	0.551	14.0	0.709	18	46
2SF30GS/2SFX30GS/2SFX30GZ	45847	0.551	14.0	0.709	18	48
2SF35ES/2SF35GS	45847	0.551	14.0	0.709	18	56
2SF22ELS	45847	0.551	14.0	0.709	18	63
2SF29ELS	45429	0.663	16.0	0.709	18	85
2SF05SEEL	544697	0.709	18.0	0.709	18	18
2SF10SEEL	544697	0.709	18.0	0.709	18	31
2SF15SEEL	544697	0.709	18.0	0.709	18	45
2SF22SEEL	544697	0.709	18.0	0.709	18	63
2SFQ25SEEL	544697	0.709	18.0	0.709	18	73
2SFQ29SEEL	544697	0.709	18.0	0.709	18	85
2SFQ35SEEL	544697	0.709	18.0	0.709	18	102
2SFQ42SEEL	831290	0.709	18.0	0.787	20	102
4SP21EL/4SP21ELR/4SP21ELU	132606	0.969	24.6	0.630	16	83
4SP29ELR/4SP29ELU	133988	0.969	24.6	0.709	18	85
4DNX25GSI	547091	1.004	25.5	0.551	14	68
4DNX27GSI	547091	1.004	25.5	0.551	14	72
4SPX32G1I	547091	1.004	25.5	0.551	14	83
1CX013R/4DX10ER	542403	1.063	27.0	0.630	16	20
4DX15ER	542403	1.063	27.0	0.630	16	30
1CX025R	542403	1.063	27.0	0.630	16	33
4DX20ER	542403	1.063	27.0	0.630	16	40
4DX27ER	542403	1.063	27.0	0.630	16	56
4DX29GUIF	542403	1.063	27.0	0.630	16	59
4DX30ER	542403	1.063	27.0	0.630	16	62
1CX050R	542403	1.063	27.0	0.630	16	63
67DX39G1I	49367	1.102	28.0	0.551	14	103
66DX50G1I	134351	1.181	30.0	0.630	16	107
5SP30ELR/5SP30ELU	134351	1.181	30.0	0.630	16	11
5SP35ELR/5SP35ELU	134346	1.299	33.0	0.709	18	11
5SP40ELR/5SP40ELU	134333	1.299	33.0	0.787	20	11

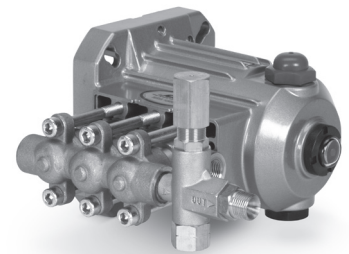

2SF Plunger Pumps

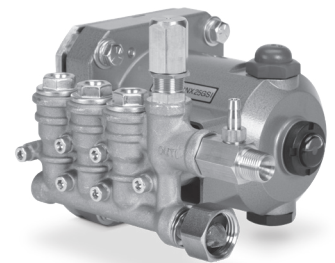

4DNX Plunger Pumps

Note: For configurations with multiple pump options, see Pump Model Number Breakdown.

Plunger Pumps – Ceramic Dimensional Reference Chart

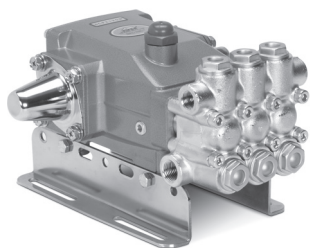

CP Plunger Pumps

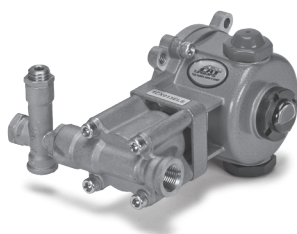

1CX Plunger Pumps
(Single Plunger)

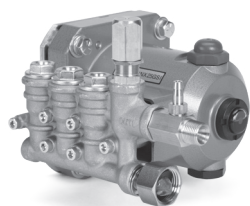

DX Plunger Pumps

MODEL	CERAMIC PN	LENGTH Inches	LENGTH mm	OD Inches	OD mm	CRANKSHAFT ID	STAMP
5CP4120CSS	49906	1.614	41.0	0.591	15	20	
5CP4110CSS	49906	1.614	41.0	0.591	15	10	
5CP4112CSS	49906	1.614	41.0	0.591	15	12	
5CP4114CSS	49906	1.614	41.0	0.591	15	14	
5CP4116CSS	49906	1.614	41.0	0.591	15	165	
5CP4118CSS	49906	1.614	41.0	0.591	15	18	
230/231/237	43901	1.693	43.0	0.709	18	73	
3CP1211CS	46976	1.693	43.0	0.709	18	15	
3CP1130/3CP1231	46976	1.693	43.0	0.709	18	73	
240/241/247	43901	1.693	43.0	0.709	18	11	
3CP1140/3CP1241	46976	1.693	43.0	0.709	18	11	
270/271/277	43901	1.693	43.0	0.709	18	127	
3CP1120/3CP1221	46976	1.693	43.0	0.709	18	127	
66DX30G1I	48752	1.850	47.0	0.551	14	86	
66DX35G1I	48752	1.850	47.0	0.551	14	10	
66DX40G1I	48752	1.850	47.0	0.551	14	114	
5CP2140WCS/5CP2140BCS/5CPQ6241CS	46841	1.969	50.0	0.787	20	10	
5CP3105CSS	46884	1.969	50.0	0.630	16	10	
5CP2150W/5CP2150B/5CPQ6251	46841	1.969	50.0	0.787	20	12	
5CP3110CSS	46884	1.969	50.0	0.630	16	14	
5CP3160CSS	46884	1.969	50.0	0.630	16	165	
5CPQ6281CSS	46841	1.969	50.0	0.787	20	14	
5CPQ6271CSS	46841	1.969	50.0	0.787	20	16.5	
5CP2120W/5CP2120B/5CP6120/5CPQ6221	46841	1.969	50.0	0.787	20	18	
5CP3120/5CP3120CSS	46884	1.969	50.0	0.630	16	18	
5CP3150CSS	46884	1.969	50.0	0.630	16	20	
5CP5120/5CP5120CSS/5CP5135CSS	49655	1.969	50.0	0.709	18	18	
5CP5140/5CP5140CSS	49655	1.969	50.0	0.709	18	20	
5CP6180CSS	121391	1.969	50.0	0.866	22	165	
5CP6190	121391	1.969	50.0	0.866	22	20	
7CP6160CS	134938	2.086	53.0	0.707	20	26	
7CP6110CS/7CP6111CS/7CP6111CSS	48559	2.165	55.0	0.866	22	217	
7CP6170/7CP6171CS/7CP6171CS	48559	2.165	55.0	0.866	22	26	
1540E/1540EC/1541/1541C	48938	2.559	65.0	1.181	30	—	
30/301/301C	43367	2.835	72.0	0.787	20	8	
340/340B/340S/341/341C/347	43367	2.835	72.0	0.787	20	10	
350/350B/350S/351/351C/357	43367	2.835	72.0	0.787	20	12	
310/310B/310S/311/311C	43367	2.835	72.0	0.787	20	18	
740/784KM	45890	2.835	72.0	0.551	14	15	
45	45783	2.835	72.0	0.630	16	18	
700/781/781K/781KM	45890	2.835	72.0	0.551	14	24	
760	45890	2.835	72.0	0.551	14	185	
60	43232	3.031	77.0	0.709	18	15	
57	43232	3.031	77.0	0.709	18	185	
56/56HS/530	43232	3.031	77.0	0.709	18	24	
550	43311	3.031	77.0	0.630	16	24	
650/660/661C/661D/1560	43300	3.031	77.0	0.787	20	—	
1050/1051/1051C/1051D/1057/1580	43552	3.031	77.0	0.945	24	—	
1810/1810K	76595	3.142	79.8	0.433	11	—	
1570	132150	3.268	83.0	0.630	16	—	
1730/1731	48606	3.622	92.0	0.984	25	25	
1530/1530C/1531	48606	3.622	92.0	0.984	25	—	
2560/2560BH	134986	3.661	93.0	0.866	22	—	
2565/2565BH	134968	3.661	93.0	0.984	25	—	
2530/2530E/2531/2531C/2537/2831/2831K	45749	3.661	93.0	1.260	32	—	
3550	132953	4.331	110.0	0.787	20	—	
2510/2511/3560	48535	4.331	110.0	0.984	25	—	
6810	76347	4.803	122.0	0.827	21	—	
3501/3501C/3507/3507C/3801/3801K	43945	5.709	145.0	0.787	20	—	
3511/3511C/3517/3517C/3811/3811K	43866	5.709	145.0	0.984	25	—	
3520/3520C/3521DHS/3521C/3527/3570/3570C 3570S/3821HS/3821KHS/6821/6821K	43957	5.709	145.0	1.260	32	—	
3531D/3531C/3535/3535C/3537/3831/3831K	43921	5.709	145.0	1.575	40	—	
3541D/3541C/3545/3547/3547C/3841/3841K	46806	5.709	145.0	1.772	45	—	
6801/6801K/6811/6811K	43866	5.709	145.0	0.984	25	—	
6831/6831K/6832/6835/6835K	43921	5.709	145.0	1.575	40	—	
67070	134489	6.220	158.0	1.772	45	—	
67102/67102C	133721	6.850	174.0	2.440	62	—	
6747/6841/6841K	45672	7.283	185.0	1.772	45	—	
6760/6761/6762/6767/6767C/6775/6861/6861K	44749	7.283	185.0	2.165	55	—	

Note: For configurations with multiple pump options, see Pump Model Number Breakdown.

Obsolete Plunger Pumps – Ceramic Dimensional Reference Chart

MODEL	CERAMIC PN	LENGTH Inches	LENGTH mm	OD Inches	OD mm	CRANKSHAFT ID STAMP
2SF22ES	45847	0.551	14.0	0.709	18	335
4SF30GS1	45848	0.945	24.0	0.787	20	44
4SF35GS1	45848	0.945	24.0	0.787	20	50
4SF40GS1	45848	0.945	24.0	0.787	20	57
4SF45GS1	45848	0.945	24.0	0.787	20	65
4SF50GS1	45848	0.945	24.0	0.787	20	70
4SF32ELS	45848	0.945	24.0	0.787	20	79
4SF40ELS	45848	0.945	24.0	0.787	20	97
4SF45ELS	45848	0.945	24.0	0.787	20	111
4SF50ELS	45848	0.945	24.0	0.787	20	115
3DNX25GSI	547091	1.004	25.5	0.551	14	68
3DNX27GSI	547091	1.004	25.5	0.551	14	72
3SP30G1I/3SPX30G1I	547091	1.004	25.5	0.551	14	8
3SP35GEI/3SPX35GEI	547091	1.004	25.5	0.551	14	88
1DX015ELS.MIST/1DX03ELS.MIST/ 2DX05ELS.MIST	542403	1.063	27.0	0.630	16	20
2DX15ES/2DX15ES.MIST	542403	1.063	27.0	0.630	16	30
2DX20ES/2DX20ES.MIST	542403	1.063	27.0	0.630	16	40
3DX25GSI	542403	1.063	27.0	0.630	16	52
2DX27ES/2DX27ES.MIST/3DX27GSI	542403	1.063	27.0	0.630	16	56
3DX29GSI	542403	1.063	27.0	0.630	16	59
2DX30ES/2DX30ES.MIST/3DX30GSI	542403	1.063	27.0	0.630	16	62
2DX30GS	542403	1.063	27.0	0.630	16	64
4HP35G1/5DX35G1	46524	1.693	43.0	0.630	16	79
4HP40G1/5DX40G1	46524	1.693	43.0	0.630	16	9
3CP1131	46976	1.693	43.0	0.709	18	73
3CP1141	46976	1.693	43.0	0.709	18	11
3CP1121	46976	1.693	43.0	0.709	18	127
5DX30G1	46727	1.850	47.0	0.630	16	64
6DX35G1I	48752	1.850	47.0	0.551	14	10
5DX50G1	46727	1.850	47.0	0.630	16	112
6DX40G1I	48752	1.850	47.0	0.551	14	114
5CP6141/5CP6241CS	46841	1.969	50.0	0.787	20	10
5CP6151/5CP6251	46841	1.969	50.0	0.787	20	12
5CP5150	49655	1.969	50.0	0.709	18	16
5CP5140	49655	1.969	50.0	0.709	18	20
5CP3130	46884	1.969	50.0	0.630	16	165
5CP6121/5CP6221	46841	1.969	50.0	0.787	20	18
1540	48938	2.559	65.0	1.181	30	30
42HS	45783	2.835	72.0	0.630	16	85
34/340W	43367	2.835	72.0	0.787	20	10
43HS	45890	2.835	72.0	0.551	14	11
35/350W	43367	2.835	72.0	0.787	20	12
31/310W	43367	2.835	72.0	0.787	20	18
70	45890	2.835	72.0	0.551	14	24
58	43232	3.031	77.0	0.709	18	17
51	43311	3.031	77.0	0.630	16	185
59	43232	3.031	77.0	0.709	18	185
55	43311	3.031	77.0	0.630	16	24
53	43232	3.031	77.0	0.709	18	24
654	43232	3.031	77.0	0.709	18	—
651/681/681K/1861/1861K/1861KM	43300	3.031	77.0	0.787	20	—
1851/1851K	43552	3.031	77.0	0.945	24	—
3510	43945	5.709	145.0	0.787	20	—
6771/6777	44749	7.283	185.0	2.165	55	—

Note: For configurations with multiple pump options, see Pump Model Number Breakdown.

Serial Numbers

The serial number is stamped on the crankcase near the mounting feet for most models. On SF models, this number is on a label located on the flange of the pump.

The serial number lists the month and year of production in the first three characters. The date of production can assist you in determining the effective dates for changes in pump construction, performance or design, which will be listed on our Technical Bulletins.

The first character of the serial number indicates the month of production. Months are noted with a number for January through September (1, 2, 3, etc.) and a letter from October through December (O, N, and D). The second and third characters indicate the year of production.

- Example: Serial Number N010101 means the pump was built in November 2001 (N01).
- Example: Serial Number 2020253 means the pump was built in February 2002 (202).

Pump Model Number Breakdown

Once you have tentatively identified the possible pump models based on the plunger and crankshaft ID stamp combinations, the model number and suffix provide more information about the pump. Please read below to determine various manifold materials or configurations, seals or O-ring materials, shaft sizes, electric or gas drives, etc.

The last numerical digit in a three or more digit model number indicates the specific manifold material, manifold configuration, or if it has cups or cylinders/sleeves.

Suffix	Examples	
0	280 310	Base models equipped with Buna-N seals and O-rings Piston pump Plunger pump
1	281 311	316 stainless steel manifolds 304 stainless steel valves – piston pumps 316 stainless steel valves – plunger pumps
2	432 6762	Piston pumps Unchromed 304 stainless steel cylinders, sleeves and manifolds Plunger pumps Duplex stainless steel manifolds
3	333	Piston pumps Machined high-pressure cups, standard manifold
4	6864	Plunger pumps Super duplex stainless steel block-style manifolds
5	335	Piston pumps Pulse ported discharge manifold
6	436	Piston pumps Unchromed 304 stainless steel cylinders and sleeves, standard manifold
7	317	Nickel aluminum bronze Plunger pump

The last three or four alpha characters in a model number covers a wide range of options as noted.

B	5CP2120B	Special formulated brass manifolds Plunger pump
BH	2560BH	Bell housing ready Plunger pump
C	2520C 311C	Flushed inlet manifold Piston pump Plunger pump
C1	290C1 340C1	Clutch pump – 1 groove Piston pump Plunger pump
C2	290C2 340C2	Clutch pump – 2 grooves Piston pump Plunger pump
CS	3CP1120CS	Single shaft, right side Plunger pump
CSS	5CP3120CSS	Single shaft, right side, side gauge left Plunger pump
D	661D	Duplex stainless steel Plunger pump
E	1540E	Epoxy painted, special liquid gasket Plunger pump
EES	2SF10EES	Direct drive – electric, 5/8" hollow shaft, no unloader, 3450 RPM Plunger pump
EL	4SP21EL	Direct drive – electric, 5/8" hollow shaft, no unloader, 1750 RPM Plunger pump

Suffix	Examples	
ELS	2SF22ELS 5SP30ELR	Direct drive – electric, with unloader, 1725 RPM Plunger pump – 5/8" hollow shaft Plunger pump – 1 1/8" hollow shaft
ER	4DX10ER	Direct drive – electric, 5/8" hollow shaft, integral regulator, 3450 RPM Plunger pump
ES	2SF22ES	Direct drive – electric, 5/8" hollow shaft, with unloader, 3450 RPM Plunger pump
EUF	4DX15EUF	Direct drive – electric, 5/8" hollow shaft, integral unloader, garden hose fitting, 3450 RPM Plunger pump
G	3CP1120G	Gearbox pump – 3/4" shaft Plunger pump
G1	45G1	Gearbox pump – 1" shaft Plunger pump
G118	56G118	Gearbox pump – 1 1/8" shaft Plunger pump
G1I	66DX40G1I	Direct drive – gas, 1" hollow shaft, with unloader, chemical injector, 3400 RPM Plunger pump
GES	2SF35GES	Direct drive – electric, 3/4" hollow shaft, with unloader, 3450 RPM Plunger pump
GG1	66DX40GG1	Direct drive – gas, 1" hollow shaft, no unloader, 3400 RPM Plunger pump
GS	2SF30GS	Direct drive – gas, 3/4" hollow shaft, with unloader, 3450 RPM Plunger pump
GSI	4DNX25GSI	Direct drive – gas, 3/4" hollow shaft, chemical injector, integral unloader, 3450 RPM Plunger pump
GZ	2SF30GZ	Direct drive – gas, 3/4" hollow shaft, with unloader, 3450 RPM Plunger pump
HS	3507HS	High-strength drive-end Plunger pump
HYD	3K121HYD	Hydraulic-powered pump unit Centrifugal pump
K	781K	Flushed block-style inlet manifold Plunger pumps
P	1560P	Manifold with pulsator assembly Plunger pump
RS	56RS	Reverse shaft Plunger pump
RSS	5CP3160RSS	Reverse shaft left side, side gauge right side Plunger pump
S	310S	Solid stainless steel inserts Plunger pump
SEEL	2SF22SEEL	Direct drive – electric, 5/8" hollow shaft, no unloader, 1725 RPM, SS Manifolds Plunger pump
W	5CP2120W	Special W770 alloy manifolds Plunger pump

The suffix numbering following the period after the base number covers valves (flat), inverting manifolds, seals, cups and O-rings:

Suffix	Examples	
.0001	820.0001	Flat valve assemblies found in piston pumps Standard in 25 and 60 frame piston pumps (quiet valves are standard in 3, 4, 5 and 10 frame piston pumps)
.0005	333.0005	Inverted inlet and discharge manifolds on both piston and plunger pumps
.0008	290.0008	Inverted inlet manifolds on both piston and plunger pumps
.0009	390.0009	Inverted discharge manifolds on both piston and plunger pumps
.0090	781K.0090	Piston or plunger pumps with 90 duro O-rings
.0100	280.0100	Piston or plunger pumps with FPM seals
.0110	310.0110	Piston or plunger pumps with FPM seals and O-rings
.0220	310.0220	Piston or plunger pumps with EPDM seals and O-rings
.0300	333.0300	Piston pumps with Blue Dot Seals
.0700	1050.0700	Piston or plunger pumps with PTFE seals and NBR O-rings
.0710	1810.0710	Piston or plunger pumps with PTFE seals and FPM O-rings
.0770	1050.0770	Piston or plunger pumps with PTFE seals and O-rings
.0777	3531.0777	Piston or Plunger pumps with PTFE seals and PTFE backup rings, O-rings
.3000	430.3000	Piston or Plunger pumps with high-temperature, high-pressure cups or seals Piston pump – V-hot cups
	56.3000	Plunger pump – high-temperature high-pressure seal
.3400	3CP1130.3400	Plunger pump high-temperature high-pressure seal or V-packing, special blend PTFE low-pressure seals
.3410	1051.3410	Plunger pump high-temperature high-pressure seal or V-packing, special blend PTFE low-pressure seals, FPM O-rings
.4400	1540E.4400	Piston or plunger pumps with special blend PTFE high and low-pressure seals
.4410	241.4410	Plunger pumps with special blend PTFE high and low-pressure seals, FPM O-rings
.44101		Plunger pump seals and O-rings
	1050.44101	Special-blend PTFE high-pressure and low-pressure seals, FPM O-rings, FPM crankcase seals and O-rings
.6000	1051.6000	Piston or plunger pumps with silicone free seals and O-rings
.9000	550.9000	Piston or plunger pumps – rebuilt

Cat Pumps configures a number of pumps for special applications and certifications such as ATEX, CO2, TEG, Flushed, High-Temperature and others. Need help determining your pump model? Contact us at (763) 780-5440 or techsupport@catpumps.com.

Cat Pumps

Technical Services Department

99TCH036 Rev C 22256 11/21