

DATA SHEET

PRESSURE-SENSITIVE REGULATING UNLOADER



Brass Model: 7630



FEATURES

- Provides system pressure setting and protection for single gun, non-weep and single pump applications.
- Maintains full system pressure while running in bypass with minimal load on pump.
- Compact size allows for easy installation.
- Adjusting cap permits easy adjustments of pressure.
- Unloader comes standard with NBR O-rings. Alternate O-ring materials are available for higher temperatures and chemical compatibility.

SPECIFICATIONS

	U.S.	Metric
Flow Range	2.0–10.5 gpm	7.6–40 lpm
Pressure Range	507–5076 psi	35–350 bar
Maximum Temperature (NBR)	140° F	60° C
Inlet Port	3/8" BSPP(M)	3/8" BSPP(M)
Discharge Port	3/8" BSPP(F)	3/8" BSPP(F)
Bypass Port	1/2" BSPP(F)	1/2" BSPP(F)
Auxiliary Port (Optional)	1/4" BSPP(F)	1/4" BSPP(F)
Weight	1.87 lbs	0.85 kg
Dimensions	6.62 x 3.66 x 1.75"	168 x 93 x 44 mm

Note: Use only at above specifications to ensure proper unloader life and performance.

 This Pressure-Sensitive Regulating Unloader can be converted to a Secondary Relief Valve. See page 4 for Relief Valve conversion.

ALTERNATIVE O-RING CONFIGURATION

MATERIAL	SUFFIX CODE	MAXIMUM TEMPERATURE	
NBR	—	140° F	(60° C)
FPM	.0110	240° F	(115° C)

Read all CAUTIONS and WARNINGS before commencing service or operation of any high-pressure system

SELECTION

This pressure-sensitive regulating unloader is designed for systems with single pumps, solenoid (gate) valves and nozzles and shut-off guns. Weep guns are not recommended with this unloader.

Note: For multiple-pump systems, it is best to use a pressure regulator, not a pressure-sensitive regulating unloader.

This unloader should meet both the desired system flow (combined nozzle flow rate requirement) and the desired system pressure.

NOTICE Operation below the minimum rated flow of the unloader causes the unloader to cycle. Operation above the maximum rated flow of the unloader causes cycling and premature wear, preventing achieving the desired system pressure.

INSTALLATION

This unloader operates properly when mounted in any direction. However, keeping the plumbing to a minimum and the red handle cap easily accessible is preferred. The ideal mounting location is directly onto the pump's discharge manifold.

The inlet connection is a 3/8" BSPP(M) port. An arrow and the word IN are marked into opposite sides of the body indicating the direction of flow. Liquid from the discharge of the pump goes into this connection.

The discharge connection is a 3/8" BSPP(F) port located on the front side (hex end). There is an arrow and the word OUT marked on the body, indicating the direction of flow. Plumbing to the spray guns, solenoid (gate) valves or nozzles connect here.

The bypass connection is a 3/8" BSPP(F) sized port located on the bottom. An arrow and the word BY-PASS are marked into opposite sides of the body. Bypass liquid is directed out of this port and can be routed to a reservoir (preferred method), drain or pump inlet.

OPERATION

This unloader holds established system pressure in the discharge line when the trigger gun is closed or solenoid (gate) valve is closed or the nozzle is clogged, thus bypassing all unrequired flow. Squeezing the trigger gun or opening the solenoid (gate) valve will close off the bypass and return to established system pressure.

PRESSURE ADJUSTMENT

Note: Pressure is not set at the factory.

1. Setting and adjusting the unloader pressure must be done while the system is running.
2. Start the system with unloader backed off to the lowest pressure setting (counterclockwise direction).
3. Increase the unloader pressure setting by turning the red handle cap clockwise.
4. Squeeze the trigger and read the pressure on the gauge at the pump.

Note: Do not read the pressure at the gun or nozzle.

5. If more pressure is desired, release the trigger, turn red handle cap one quarter turn in clockwise direction.
6. Squeeze the trigger and read the pressure.
7. Repeat this process until desired system pressure is reached.
8. If desired system pressure cannot be reached, review TROUBLESHOOTING chart.

NOTICE A secondary pressure safety relief device (e.g. pop-off valve, relief valve) should be used along with this pressure-sensitive regulating unloader. Final adjustment for the secondary relief valve should be approximately 200 psi above the system operating pressure.

Note: A minimum of 5% of the flow through the unloader should bypass for proper regulator performance. If the entire unloader flow pumps through the nozzle (zero-bypass), the valve can easily be set for pressure higher than the desired pressure, causing a malfunction or premature wear

Note: By removing the check valve and spring, this unloader can function as a secondary relief valve.

🔧 See page 4 for Relief Valve conversion.

TYPICAL UNLOADER INSTALLATION

1. Pressure Gauge
2. Pop-Off Valve
(Secondary Pressure Relief Device)
3. **Pressure-Sensitive Regulating Unloader**
(Primary Pressure Regulating Device)
4. Triplex Plunger Pump

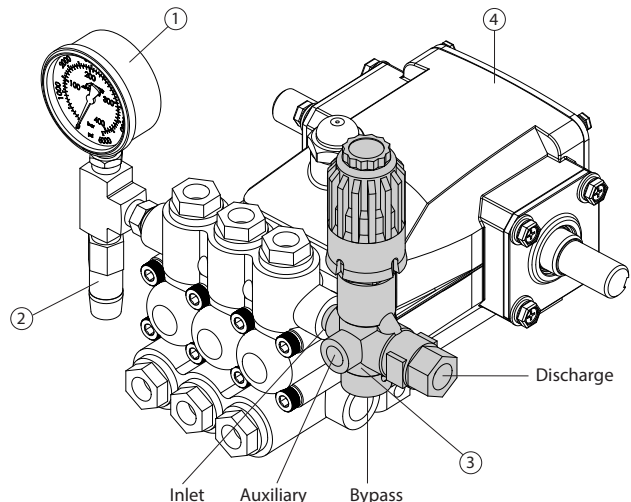

Read all CAUTIONS and WARNINGS before commencing service or operation of any high-pressure system

SERVICING

Disassembly

1. Disconnect bypass, discharge and inlet plumbing from unloader.
2. Remove unloader from pump.
3. Secure body of unloader in a vise with red handle cap facing up.
4. Remove discharge fitting and O-ring, spring, check valve and O-ring, check valve seat and O-ring

Note: If check valve seat remains in the unloader, exercise caution in removing to avoid damage to unloader walls and seat.

5. Examine check valve, check valve seat and discharge fitting for wear, spring for wear or fatigue and O-rings for cuts or wear. Replace as needed.

Note: While the discharge fitting is removed, inspect sealing area for grooves, pitting and wear. Where the check valve makes contact within the internal body of the unloader. If damage is found, stop the repair and replace with complete new unloader. If not, proceed with disassembly.

6. Remove red handle cap. Please note the brass adjusting cap will stay in the red handle cap.
7. Remove spring, spring retainer and ball.
8. Examine spring, spring retainer and ball for scale build up, fatigue or wear. Replace as needed.
9. Loosen set screw in the lock nut. Turn lock nut counterclockwise (away from the body) to allow a wrench to be used on the piston retainer.
10. Use a wrench to remove piston retainer. Pull upwards to remove the piston retainer along with the piston stem, spacer ring and valve/ball assembly.
11. Remove body from vise and reposition so the bypass port is facing up.
12. Use a tool in the bypass port to push the valve seat with O-ring out.
13. Examine seat for scale build up, scoring and wear. Replace as needed. Examine O-ring for cuts or wear. Replace as needed.
14. Remove unloader body from vise and place the piston retainer assembly into the vise.
15. Removal of piston stem and valve/ball assembly from the piston retainer requires the use of a M16 wrench and 6mm Allen wrench. Place M16 wrench onto hex surface of valve/ball assembly and then insert 6mm Allen wrench from the top and place into head of piston stem. Unthread by turning in a counterclockwise direction to separate.
16. Examine piston retainer, piston stem, spacer ring and valve/ball assembly for scale build up, scoring, pitting and wear. Replace as needed. Examine all O-rings and backup rings for cuts or wear. Replace as needed.

Reassembly

1. Place unloader body in a vise with bypass port facing down.
2. Lubricate and install O-ring on valve seat. Insert and press the valve seat into place.
3. Lubricate and install O-ring onto piston retainer.
4. Lubricate and install O-ring and backup ring onto piston stem.
5. Lubricate and install O-ring and backup ring into counterbored end of spacer ring.
6. Lubricate and install O-ring onto outside diameter of spacer ring.
7. Insert threaded end of piston stem into piston retainer and press into place.
8. Apply a drop of Loctite® 242® to the first few threads of the piston stem.
9. Place counter bored end of spacer onto piston retainer.
10. Hand thread the valve/ball assembly onto the piston stem.
11. Using the same tools from the disassembly, place 6mm Allen wrench through the top of the piston retainer and into head of piston stem. Then use the M16 wrench on the hex surface of the valve/ball assembly and tighten.
12. Insert complete assembly into unloader body and thread into place.
13. Lubricate and install O-ring on discharge fitting.
14. Lubricate and install O-ring onto check valve seat. Insert check valve seat with O-ring into unloader body. Insert spring into discharge fitting, then insert check valve with large opening facing the spring. Hand thread into unloader body and tighten with a wrench.
15. Place spring retainer on top of piston stem.
16. Place spring onto spring retainer.
17. Hand thread red handle cap onto piston retainer.
18. Remove unloader from vise.
19. Re-install unloader onto pump.
20. Reconnect bypass, discharge and inlet plumbing to the unloader.
21. Proceed to PRESSURE ADJUSTMENT

Loctite® and 242® are registered trademarks of the Henkel Corporation.

TROUBLESHOOTING

Unloader cycles	<ul style="list-style-type: none"> • Check valve O-ring is worn out • Fitting leaking downstream • Worn O-ring inside gun • Insufficient flow through unloader
Liquid leaking from bottom	<ul style="list-style-type: none"> • Seat or inlet fitting O-ring is cut or worn
Liquid leaking from middle	<ul style="list-style-type: none"> • Piston O-ring is worn or cut
Unloader will not come up to pressure	<ul style="list-style-type: none"> • Not properly sized for system pressure • Foreign material in unloader • Piston O-rings worn • Nozzle worn or too large • Pressure adjuster is not properly set
Extreme pressure spikes	<ul style="list-style-type: none"> • Adjusting handle turned completely into unloader • Restricted bypass or no bypass • System flow exceeds unloader rating

PARTS LIST

ITEM	P/N	MATL	DESCRIPTION	QTY
401	31295	NYBB	Cap, Handle Red	1
402	31167	BB	Cap, Adjusting	1
403	31727	BB	Nut, Locking (M27 x 1)	1
404	33061	STZP	Screw, Set (M4 x 4)	1
405	32289	SSSS	Ball (1 ¹ / ₃₂ "	1
408	31143	STL	Spring	1
410	34574	BB	Retainer, Spring	1
412	—	SS	Piston	1
414	—	PTFE	Backup Ring, Piston	1
415	—	NBR	O-Ring, Piston	1
423	34582	BB	Spacer	1
424	33043	NBR	O-Ring, Spacer	1
425	31159	BB	Retainer, Piston	1
428	32926	NBR	O-Ring, Piston-85D	1
429	—	NBR	O-Ring, Piston-85D	1
430	—	PTFE	Backup Ring, Piston Retainer	1
435	34581	SS	Valve and Ball Assembly (M8)	1
436	34575	SS	Seat	1
437	—	NBR	O-Ring, Seat	1
438	31153	S	Seat, Check Valve	1
439	—	NBR	O-Ring, Check Valve Seat	1
440	—	FBB	Housing	1
443	33339	S	Valve, Check with O-Ring	1
444	33843	S	Spring	1
446	—	NBR	O-Ring, Discharge Fitting	1
460	31855	BB	Fitting, Discharge (3/8" BSPP(F))	1
468	31155	NBR	Kit, O-Ring (Includes: 414, 415, 424, 428, 429, 430, 437, 439, 441, 446)	1
	32211	FPM	Kit, O-Ring (Includes: 414, 415, 424, 428, 429, 430, 437, 439, 441, 446)	1

Italics are optional items.

MATERIAL CODES (Not Part of Part Number): BB=Brass FBB=Forged Brass
 NBR=Medium Nitrile (Buna-N) NY=Nylon PTFE=Pure Polytetrafluoroethylene
 S=304SS SS=316SS SSSS=440SS STL=Steel STZP=Steel/Zinc Plated

EXPLODED VIEW

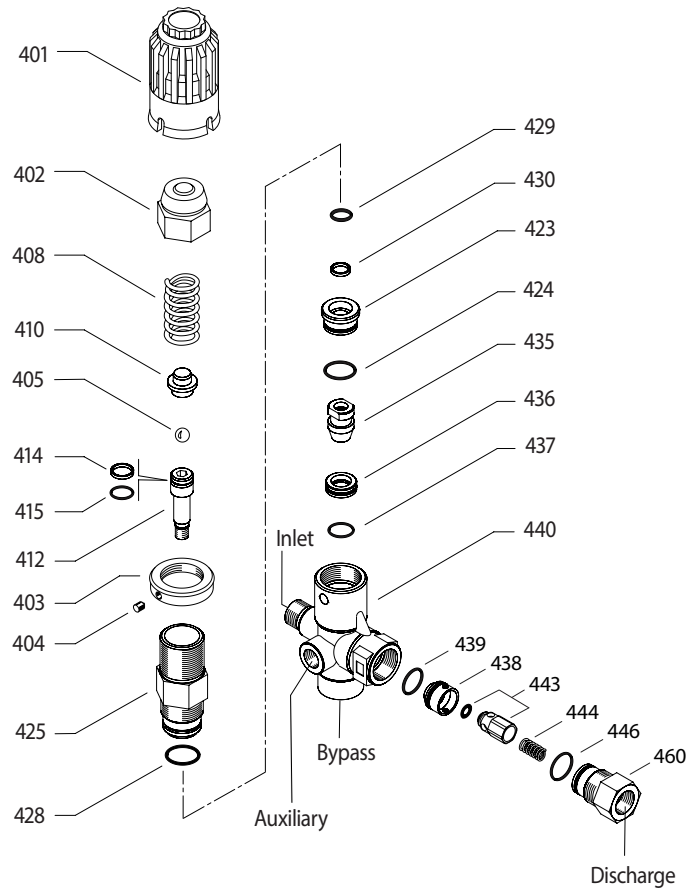

REGULATING UNLOADER TO RELIEF VALVE CONVERSION

The 7630 Pressure-Sensitive Regulating Unloader is typically used as a primary pressure regulating device. It can be converted to a Relief Valve to be used as a secondary pressure relief device by removing the discharge check valve with O-ring, spring and check valve seat with O-ring.

Unloader PN	Modifications	Converted Relief Valve PN	
7630	Remove parts 438, 439, 443, 444	7630.100 (NBR Seals)	7630.1110 (FPM Seals)

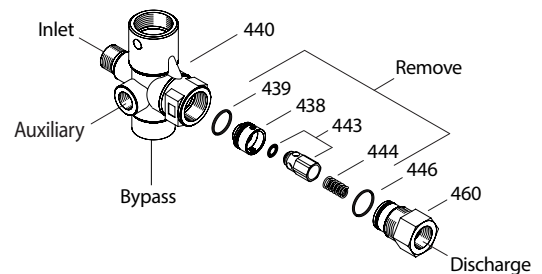

CAUTIONS AND WARNINGS

All high-pressure systems require a primary pressure regulating device (e.g. regulator, unloader) and a secondary pressure relief device (e.g. pop-off valve, relief valve). Failure to install such relief devices could result in personal injury or damage to pump or property. Cat Pumps does not assume any liability or responsibility for the operation of a customer's high-pressure system. Read all CAUTIONS and WARNINGS before commencing service or operation of any high-pressure system. The CAUTIONS and WARNINGS are included in each Service Manual and with each Accessory Data sheet. CAUTIONS and WARNINGS can also be viewed online at www.catpumps.com/dynamic-literature/cautions-and-warnings or can be requested directly from Cat Pumps.

WARRANTY

View the Limited Warranty online at www.catpumps.com/literature/cat-pumps-limited-warranty