

DATA SHEET

35 FRAME PLUNGER PUMPS



Brass Models: 3570, 3570S

Flushed Model: 3570C

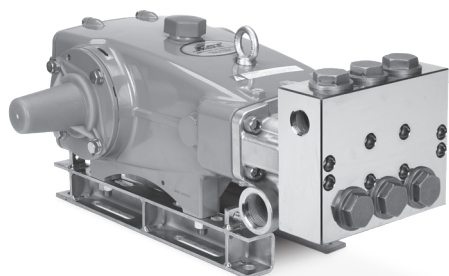

Model 3570 Shown
(Shaft protector included, mounting rails sold separately)

FEATURES

- Triplex plunger design ensures high efficiency and low pulsation.
- V-packings and low-pressure seals are completely lubricated and cooled by pumped liquid.
- Special high-density, polished concentric plungers provide a true wear surface and extended seal life.
- Model 3570C offers an external flush for high-temperature or low-lubricity liquids.
- Pump comes standard with NBR seals. Alternative seal materials are available for higher temperature or chemical compatibility.

SPECIFICATIONS

	U.S. Measure	Metric Measure
Flow*	30 gpm	114 lpm
Pressure Range (3570, 3570C)	100–2500 psi	6.9–170 bar
Pressure Range* (3570S)	100–3000 psi	6.9–207 bar
Pump RPM**	1080 rpm	1080 rpm
Inlet Pressure Range	Flooded to 70 psi	Flooded to 4.8 bar
Maximum Liquid Temp. (NBR)	120° F	48° C
Alternative seals available for higher temperatures up to 140° F		
Bore	1.260"	32 mm
Stroke	1.890"	48 mm
Crankcase Capacity	4.2 qts	4 l
Inlet Ports (2)	1½" NPT(F)	1½" NPT(F)
Flush Ports (2)	¼" NPT(F)	¼" NPT(F)
Discharge Ports (2)	1" NPT(F)	1" NPT(F)
Shaft Diameter	1.378"	35 mm
Pulley Mounting	Either Side	Either Side
Weight	138.9 lbs	63 kg
Dimensions	23.94 x 18.11 x 9.74"	608 x 460 x 247 mm

*Intermittent duty only

**Pump minimum is 100 RPM.

INTERMITTENT DUTY CYCLE DEFINED AS:

Operating pump at maximum rated flow and pressure for no more than 50% of the time in any given hour.

ALTERNATIVE SEAL CONFIGURATION

MATERIAL	SUFFIX CODE	MAXIMUM TEMPERATURE	
NBR	—	120° F	(48° C)
FPM	.0110	140° F	(60° C)
EPDM	.0220	160° F	(71° C)

See **Tech Bulletin 002** for inlet conditions and RPM at high-temperature.

**DETERMINING
THE PUMP RPM**

$$\frac{\text{Rated gpm}}{\text{Rated rpm}} = \frac{\text{Desired gpm}}{\text{Desired rpm}}$$

**DETERMINING
THE REQUIRED HP**

$$\frac{\text{hp}}{\text{(Electric Brake)}} = \frac{\text{gpm x psi}}{1460}$$

**DETERMINING
MOTOR PULLEY SIZE**

$$\frac{\text{Motor Pulley OD}}{\text{Pump rpm}} = \frac{\text{Pump Pulley OD}}{\text{Motor rpm}}$$

Refer to pump **Service Manual** for repair procedure and additional technical information.

PARTS LIST

ITEM	P/N	MATL	DESCRIPTION	QTY
5	96049	S	Screw, HHC, Sems (M10 x 25) (See Tech Bulletins 074, 125)	8
8	134604	ALE	Cover, Bearing (See Tech Bulletins 118, 125)	2
9	815279	FBR	Shim, Split, 2-Piece (See Tech Bulletin 125)	2
10	12398	NBR	O-Ring, Bearing Cover-70D	2
11	13296	NBR	Seal, Oil, Crankshaft	2
12	855049	S	Shim, Split, 2-Piece	0-2
15	29326	STL	Bearing, Roller	2
20	121467	TNM	Rod, Connecting Assembly (Includes: 21, 22, 23) (See Tech Bulletin 074)	3
21	126749	STCP R	Washer, Locking (M10)	3
22	126593	STCP R	Washer, Flat (M10.5)	6
23	122045	STZP	Screw, HH (M10 x 55)	6
25	29325	FCM	Crankshaft, Dual End (M48)	1
31	828710	PE	Protector, Oil Cap with Foam Gasket	1
32	43211	ABS	Cap, Oil Filler	1
33	14177	NBR	O-Ring, Oil Filler Cap-70D	1
34	126743	STCP R	Bolt, Eye (M12 x 1.75) (For Lifting Pump Only)	1
37	92241	PC	Gauge, Oil, Bubble with Gasket	1
38	44428	NBR	Gasket, Flat, Oil Gauge-80D	1
40	125753	S	Screw, HHC, Sems (M8 x 25) (See Tech Bulletin 074)	8
48	25625	STCP	Plug, Drain (1/4" x 19 BSP)	1
49	23170	NBR	O-Ring, Drain Plug-70D	1
50	45936	ALE	Cover, Crankcase (See Tech Bulletin 118)	1
51	16612	NBR	O-Ring, Crankcase-70D	1
53	134784	ALE	Crankcase Assembly (Includes: 54) (See Tech Bulletins 118, 125)	1
54	27488	S	Pins, Guide	2
56	27790	POP	Pan, Oil	1
59	92538	S	Screw, HHC, Sems (M6 x 16)	2
64	43864	CM	Pin, Crosshead	3
65	49166	SSHB	Rod, Plunger	3
69	126587	STCP R	Washer, Oil Seal	3
70	100488	NBRS	Seal, Oil, Crankcase	3
75	43865	S	Slinger, Barrier	3
88	45676	S	Washer, Keyhole (M16)	3
90	43957	CC	Plunger (M32 x 145)	3
95	† 89778	SS	Stud, Plunger Retainer (M10 x 135)	3
96	20189	PTFE	Backup Ring, Plunger Retainer	3
97	11345	NBR	O-Ring, Plunger Retainer-70D	3
98	44085	SS	Gasket, Retainer	3
99	† 44084	SS	Retainer, Plunger (M10) (See Tech Bulletin 074)	3
100	44119	PPG	Retainer, Seal (See Tech Bulletin 105)	3
101	44106	—	Wick, Long Tab	3
104	43875	NBR	O-Ring, Adapter-70D	3
105	49741	BB	Adapter, Low-Pressure Seal	3
106	† 44098	NBR	Seal, Low-Pressure with SS-Spring	3
107	43962	S	Washer, Low-Pressure Seal	3
110	49464	BBCP R	Manifold, Inlet - (Models 3570, 3570S)	1
	49464C	BBCP R	Manifold, Inlet, Flushed (1/4" Flush Ports) - (Model 3570C)	1
112	11379	NBR	O-Ring, Inlet Manifold-70D	3
117	44585	S	Screw, HSH (M14 x 40) (See Tech Bulletin 074)	4
122	49744	BB	Spacer, V-Packing	3
123	12391	NBR	O-Ring, Spacer-70D	3
124	49742	BB	Cylinder, V-Packing	3
126	43963	BB	Adapter, Female	3
127	† 44608	STG	V-Packing	6
128	43965	BB	Adapter, Male	3
141	49743	SS	Spring, Coil	3
155	48860	NBR	O-Ring, V-Packing Cylinder-90D	3
156	48362	D	Backup Ring, V-Packing Cylinder	3
162	48363	D	Backup Ring, Valve Seat	6
163	26142	NBR	O-Ring, Valve Seat-80D	6
164	133052	S	Seat, Valve	6
166	43932	S	Valve	6
167	133053	S	Spring	6
168	44728	PVDF	Retainer, Spring	6
170	44729	SS	Washer, Spring	6
171	44644	SS	Spring, Coil	6
172	89827	NBR	O-Ring, Valve Plug-90D	6
173	48364	D	Backup Ring, Valve Plug	6
174	44643	NAB	Plug, Valve	6
185	133049	BBCP	Manifold, Discharge (Models 3570, 3570C)	1
	133559	SS	Manifold, Discharge (Model 3570S)	1
188	89981	S	Screw, HSH (M12 x 70) (See Tech Bulletin 074)	8
250	855042	NY	Protector, Shaft with 2 Screws, Lockwashers and Washers (Included with Pump) (See Tech Bulletin 125)	1

Optional Parts and Accessories and Service parts listed on page 3. Standard and optional Seal and Valve Kits listed on page 4.

EXPLODED VIEW

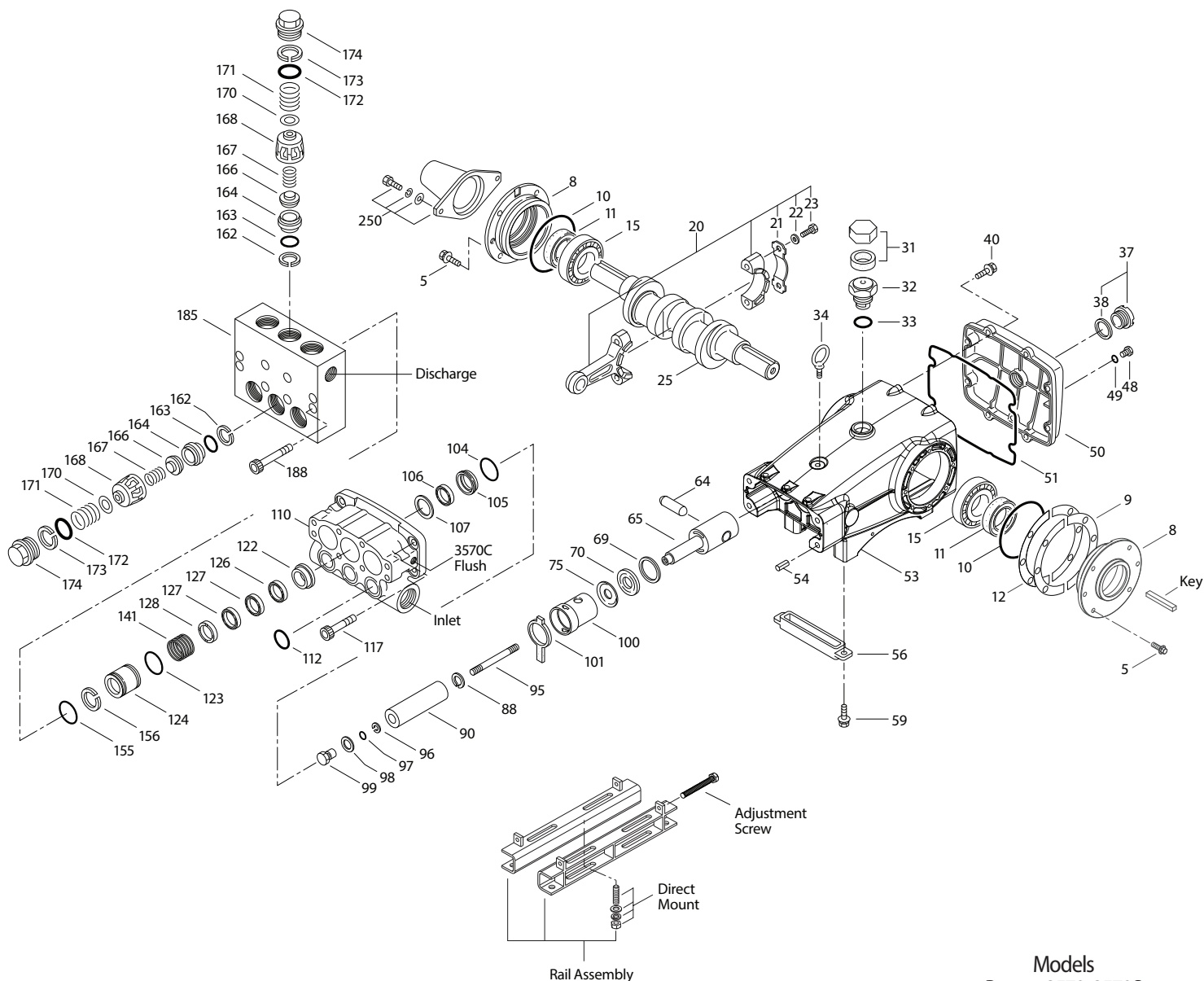

Models
 Brass – 3570, 3570S
 Brass Flushed – 3570C
 June 2023

OPTIONAL PARTS AND ACCESSORIES

PART	DESCRIPTION	QTY
34021	Key (M10 x 8 x 70)	1
92674	Mount, Rail Assembly (Includes: 34018)	1
34018	Mount, Direct	1
990013	Hub, "B", 35 mm (Not Shown)	1
80540	Screw, Adjusting (M12 x 100)	2
34334	Kit, Oil Drain (3/8" x 24") (Not Shown)	1
819000	Assembly, Crankcase, Cast Iron Conversion (Not Shown)	1

SERVICE PARTS

PART	DESCRIPTION	QTY
31039	Kit, Seal – Standard NBR	1
76794	Kit, Valve – Standard NBR	2
6100	Oil, Case (12 - 21 oz bottle) ISO-68 Hydraulic (Fill to Specified Crankcase Capacity Prior to Start-up)	1
6124	Gasket, Liquid (3 oz)	1
6139	Lubricant, Anti-seize (8 oz) (See Tech Bulletin 095)	1
818610	Head, Complete, with NBR Seals and O-Rings (Model 3570)	1
818610S	Head, Complete, with NBR Seals and O-Rings (Model 3570S)	1

Bold print part numbers are unique to a particular pump model. R Components comply with RoHS Directive.

For additional technical information see www.catpumps.com/literature/tech-bulletins. † Production parts different from service parts.

MATERIAL CODES (Not Part of Part Number): ABS=ABS Plastic ALE=Aluminum Epoxy BB=Brass BBCP=Brass/Chrome Plated CC=Ceramic CM=Chrome-Moly
 D=Acetal FBR=Fiber FCM=Forged Chrome-Moly FPM=Fluorocarbon NAB=Nickel Aluminum Bronze NBR=Medium Nitrile (Buna-N) NBR5=Buna, Silicone Free
 NY=Nylon PC=Poly Carbonate PE=Polyethylene POP=Polypropylene PPG=Glass Filled Polypropylene PTFE=Pure Polytetrafluoroethylene
 PVDF=Polyvinylidene Fluoride S=304SS SS=316SS SSHB=316SS/High Strength STCP=Steel/Chrome Plated STG=Special Blend PTFE White
 STL=Steel STZP=Steel/Zinc Plated TNM=Special High Strength

Kits – NBR, FPM (.0110), listed on page 4.

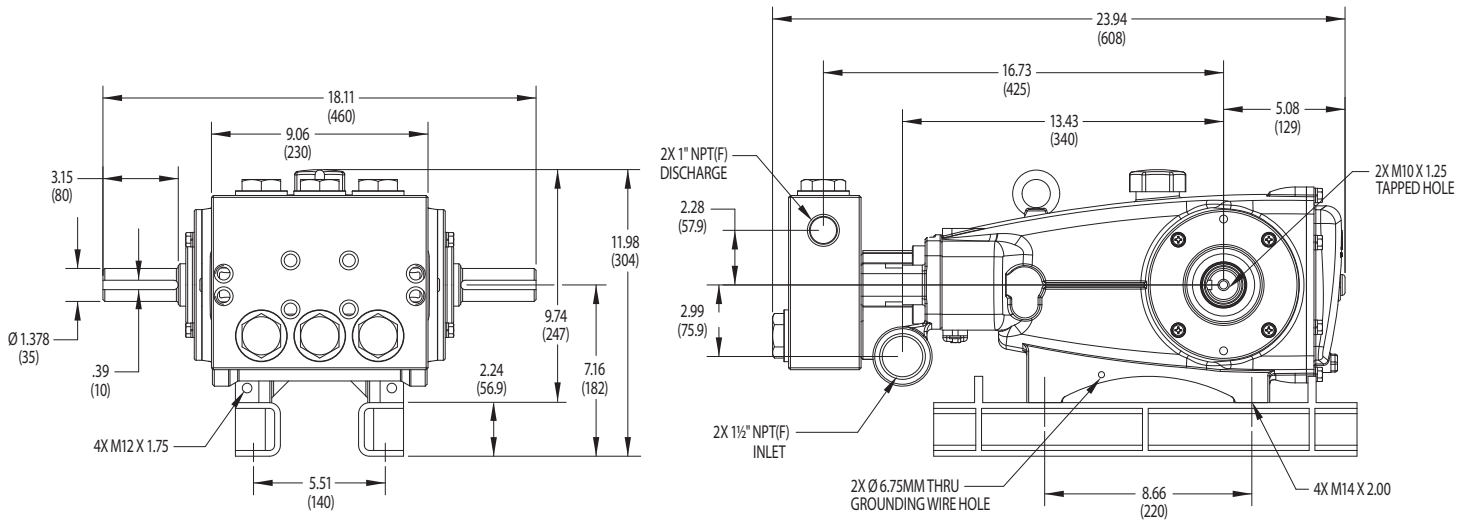

Models: 3570, 3570S

SEAL KITS One (1) seal kit required per pump

PUMP MODEL	NBR (STD)	FPM (.0110)	EPDM (.0220)
3570, 3570C, 3570S	31039*	76842*	76843*

ITEM (Included in Seal Kits)				DESCRIPTION	QTY
97	11345	11375	701490	O-Ring, Plunger Retainer	3
104	43875	44826	701656	O-Ring, Adapter	3
106	44098	44827	48244	Seal, Low-Pressure with SS-Spring	3
112	11379	14183	701491	O-Ring, Inlet Manifold	3
123	12391	13266	701657	O-Ring, V-Packing Spacer	3
127	44608	44829	44608	V-Packing	6
155	48860	20137	701492	O-Ring, V-Packing Spacer	3
156	48362	48362	48362	Backup Ring, V-Packing Spacer	3

* Review material codes for individual items (STG generally may be used as an alternative)

VALVE KITS Two (2) valve kits required per pump

PUMP MODEL	NBR (STD)	FPM (.0110)	EPDM (.0220)
3570, 3570C, 3570S	76794	76831	76869

ITEM (Included in Valve Kits)				DESCRIPTION	QTY
162	48363	48363	48363	Backup Ring, Valve Seat	3
163	26142	14330	701493	O-Ring, Discharge Seat	3
164	133052	133052	133052	Seat, Valve	3
166	43932	43932	43932	Valve	3
167	133053	133053	133053	Spring	3
168	44728	44728	44728	Retainer, Spring	3
170	44729	44729	44729	Washer, Spring	3
172	89827	11747	701494	O-Ring, Valve Plug	3
173	48364	48364	48364	Backup Ring, Valve Plug	3

⚠ CAUTIONS AND WARNINGS

All high-pressure systems require a primary pressure regulating device (e.g. regulator, unloader) and a secondary pressure relief device (e.g. pop-off valve, relief valve). Failure to install such relief devices could result in personal injury or damage to pump or property. Cat Pumps does not assume any liability or responsibility for the operation of a customer's high-pressure system. Read all CAUTIONS and WARNINGS before commencing service or operation of any high-pressure system. The CAUTIONS and WARNINGS are included in each Service Manual and with each Accessory Data sheet. CAUTIONS and WARNINGS can also be viewed online at www.catpumps.com/dynamic-literature/cautions-and-warnings or can be requested directly from Cat Pumps.

WARRANTY

View the Limited Warranty online at www.catpumps.com/literature/cat-pumps-limited-warranty