

DATA SHEET

25 FRAME PLUNGER PUMPS



Brass Model: 2530.44101

Stainless Steel Model: 2531.44101

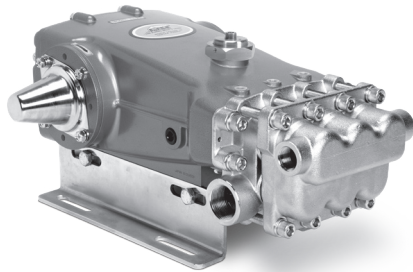

Model 2530.44101 Shown
(Shaft protector and mounting rails sold separately)

FEATURES

- Field tested, high-pressure triplex pump configured for high-temperature TEG (triethylene glycol) applications up to 240° F/115° C. May be used in other high-temperature applications with liquids possessing adequate lubrication properties. Contact Cat Pumps for more information.
- Positive displacement technology delivers optimum energy efficiency.
- TEG* pump configuration option consists of following modifications:
 - FPM elastomers and O-ring material throughout the pump.
 - Stainless steel vented oil filler cap assembly.
 - Stainless steel sight gauge assembly and aluminum adapter.
 - Aluminum seal retainers.
 - Special PTFE blended V-packings and low-pressure seals.

* TEG pump configuration is denoted by adding ".44101" to the end of the pump model.

SPECIFICATIONS	U.S. Measure	Metric Measure
Flow	25 gpm	95 lpm
Pressure Range	100–1200 psi	6.9–83 bar
Pump RPM*	1025 rpm	1025 rpm
Inlet Pressure Range	Flooded to 70 psi	Flooded to 4.8 bar
Maximum Liquid Temperature	240° F	115° C
Bore	1.260"	32 mm
Stroke	1.516"	38.5 mm
Crankcase Capacity	84 oz	2.48 l
Inlet Ports (2)	1¼" NPT(F)	1¼" NPT(F)
Discharge Ports (2)	¾" NPT(F)	¾" NPT(F)
Shaft Diameter	1.181"	30 mm
Pulley Mounting	Either Side	Either Side
Weight	68.3 lbs	31 kg
Dimensions	19.43 x 15.04 x 9.07"	493 x 382 x 230 mm

*Pump minimum is 100 RPM.

ELECTRIC HORSEPOWER REQUIREMENTS

FLOW		PRESSURE				PUMP RPM
GPM	LPM	PSI	BAR	PSI	BAR	
25	95	800	55	1000	69	1025
Horsepower						
		13.7 hp		17.1 hp		

DETERMINING THE PUMP RPM

$$\frac{\text{Rated gpm}}{\text{Rated rpm}} = \frac{\text{Desired gpm}}{\text{Desired rpm}}$$

DETERMINING THE REQUIRED HP

$$\frac{\text{hp}}{\text{(Electric Brake)}} = \frac{\text{gpm} \times \text{psi}}{1460}$$

DETERMINING MOTOR PULLEY SIZE

$$\frac{\text{Motor Pulley OD}}{\text{Pump rpm}} = \frac{\text{Pump Pulley OD}}{\text{Motor rpm}}$$

Refer to pump **Service Manual** for repair procedure and additional technical information.

PARTS LIST

ITEM	PART NUMBER	MATL	PART NUMBER	MATL	DESCRIPTION	QTY
	2530.44101		2531.44101			
5	126544	STCP R	125753	S	Screw, HHC, Sems (M8x25) (See Tech Bulletin 074)	8
8	134966	ALE	134966	ALE	Cover, Bearing (See Tech Bulletins 118, 135)	2
10	76772	FPM	76772	FPM	O-Ring, Bearing Cover-75D	2
11	76771	FPM	76771	FPM	Seal, Oil, Crankshaft	2
15	26512	STL R	26512	STL R	Bearing, Ball	2
20	48613	TNM	48613	TNM	Assembly, Rod, Connecting (Includes: Lockwasher, Washer, Screws) (See Tech Bulletin 074)	3
21	126562	STCP R	126562	STCP R	Washer, Locking	3
25	49795	FCM	49795	FCM	Crankshaft - Dual End (38.5mm)	1
32	997574	SS	997574	SS	Cap, Filler with O-Ring	1
35	76792	SS	76792	SS	Gauge, Sight	1
36	26996	FPM	26996	FPM	O-Ring, Dipstick-70D	1
37	76791	AL	76791	AL	Adapter, Sight	1
38	44428	NBR	44428	NBR	Gasket, Flat, Oil Gauge-80D	1
39	76769	AL	76769	AL	Dipstick	1
40	126544	STCP R	125753	S	Screw, HHC, Sems (M8 x 25) (See Tech Bulletin 074)	8
48	25625	STCP	25625	STCP	Plug, Drain (1/4" x 19 BSP)	1
49	30322	FPM	30322	FPM	O-Ring, Drain Plug	1
50	133582	ALE	133582	ALE	Cover, Rear (See Tech Bulletins 118, 126)	1
51	76767	FPM	76767	FPM	O-Ring, Rear Cover-70D	1
53	133609	ALE	133609	ALE	Crankcase Assembly (Includes: 54) (See Tech Bulletins 118, 135)	1
54	27488	S	27488	S	Pin, Guide	2
64	27784	CM	27784	CM	Pin, Crosshead	3
65	† 48719	SSHS	48719	SSHS	Rod, Plunger	3
70	76785	FPM	76785	FPM	Seal, Crankcase Oil	3
75	110669	S	110669	S	Slinger, Barrier	3
88	110670	S	110670	S	Washer, Keyhole	3
90	45749	CC	45749	CC	Plunger (M32 x 93)	3
95	† 89835	SS	† 89835	SS	Stud, Retainer (M7 x 87)	3
96	20184	PTFE	20184	PTFE	Backup Ring, Plunger Retainer	3
97	14161	FPM	14161	FPM	O-Ring, Plunger Retainer-70D	3
98	44069	SS	44069	SS	Gasket, Plunger Retainer	3
99	44068	SS	44068	SS	Retainer, Plunger (See Tech Bulletin 074)	3
100	76116	AL	76116	AL	Retainer, Low-Pressure	3
106	76298	ST2	76298	ST2	Seal, Low-Pressure with SS-Spring	3
110	670134	NABC	48583	SS	Manifold, Inlet	1
116	126570	STCP R	19085	S	Lockwasher	4
117	126518	STCP R	88398	S	Screw, HSH (M12 x 40) (See Tech Bulletin 074)	4
125	76832	ST4	76832	ST4	Seal, High-Pressure with S	3
143	11731	FPM	11731	FPM	O-Ring, Adapter, Low-Pressure, Rear	3
150	45752	BB	45835	SS	Adapter, Low-Pressure	3
154	11744	FPM	11744	FPM	O-Ring, Adapter, Low Pressure, Front	3
155	11745	FPM	11745	FPM	O-Ring, Adapter, Valve-70D	6
157	45751	BB	45834	SS	Adapter, Valve	3
164	† 46857	SS	† 46857	SS	Seat (See Tech Bulletin 076)	6
165	48238	FPM	48238	FPM	O-Ring, Seat	6
166	† 45839	SS	† 45839	SS	Valve	6
167	† 45840	SS	† 45840	SS	Spring	6
168	110682	PVDF	110682	PVDF	Retainer, Spring	6
185	670135	NABC	48585	SS	Manifold, Discharge	1
186	126570	STCP R	19085	S	Lockwasher	8
188	126517	STCP R	89628	S	Screw, HSH (M12 x 65) (See Tech Bulletin 074)	8

Bold print part numbers are unique to a particular pump model.

† Production parts different from service parts. R Components comply with RoHS Directive.

*Review individual parts in each kit for material code identification. For additional technical information see www.catpumps.com/literature/tech-bulletins.

MATERIAL CODES (Not Part of Part Number): AL=Aluminum ALE=Aluminum Epoxy BB=Brass CC=Ceramic CM=Chrome-moly FCM=Forged Chrome-moly FPM=Fluorocarbon NABC=Nickel Aluminum Bronze Chrome Plated NBR=Medium Nitrile (Buna-N) PTFE=Pure Polytetrafluoroethylene PVDF=Polyvinylidene Fluoride S=304SS SS=316SS STL=Steel ST2=Special PTFE 2 ST4=Special PTFE4 SSHS=316SS/High Strength STCP=Steel/Chrome Plated TNM=Special High Strength

EXPLODED VIEW

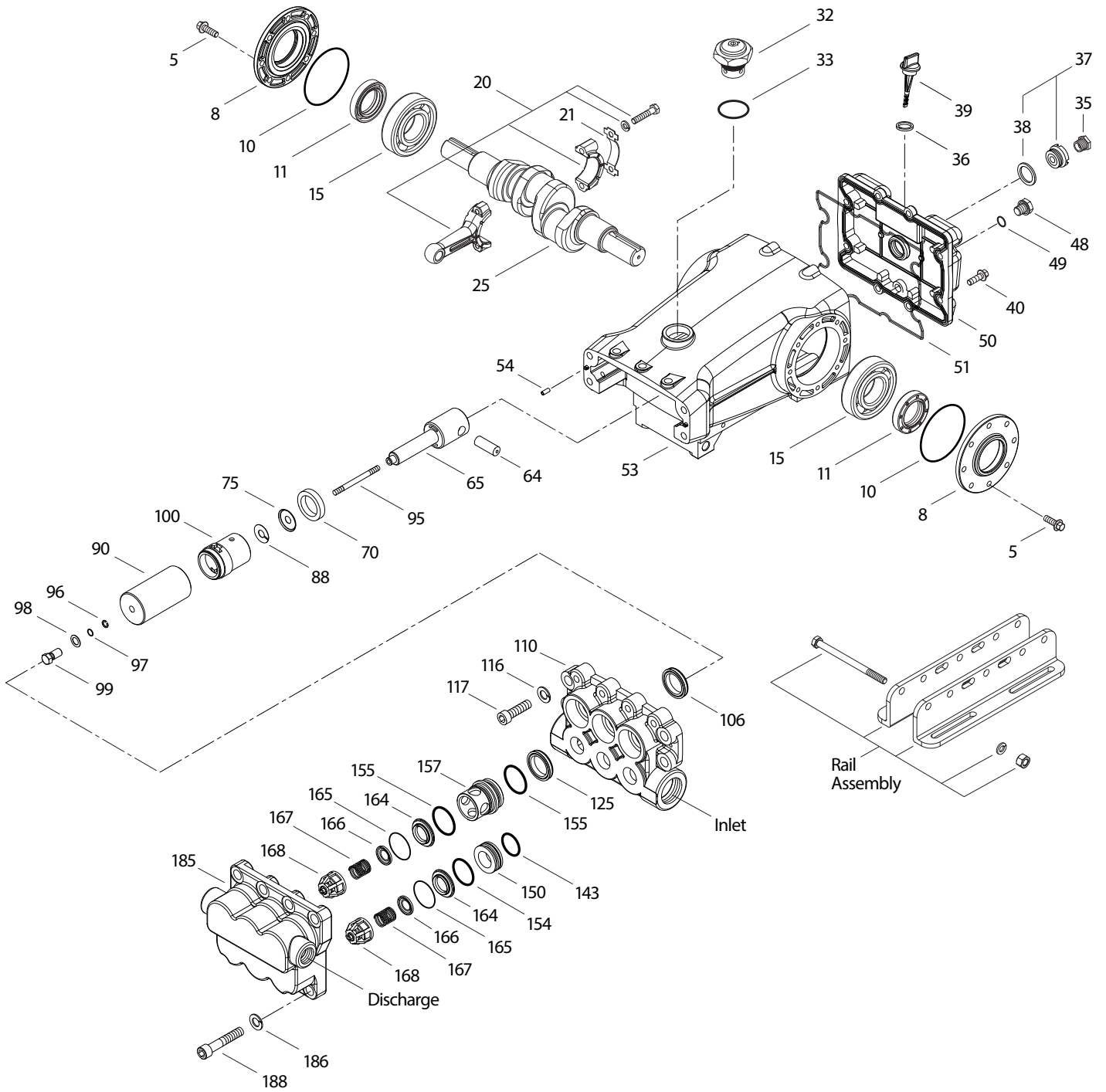

Models
 Standard – 2530.44101
 Stainless Steel – 2531.44101
 September 2023

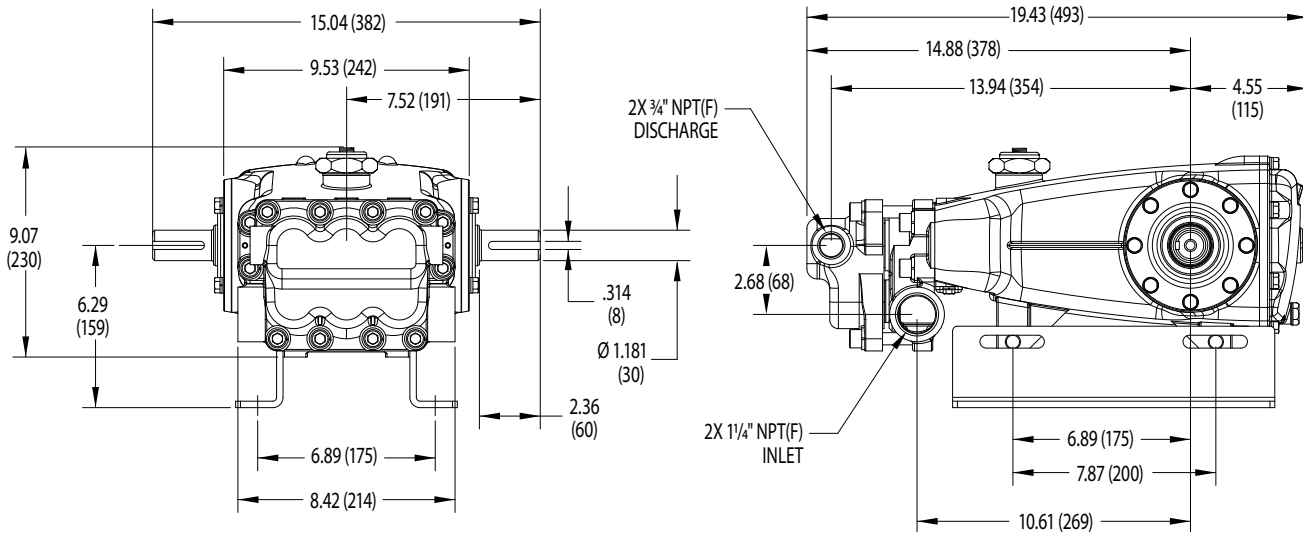

Models 2530.44101, 2531.44101

REPAIR KITS AND PARTS

Part Number	Description	QTY
76087	Kit, Seal (Includes Items: 97, 106, 125, 143, 154, 155)	1
31267	Kit, Valve (Includes Items: 143, 154, 155, 164, 165, 166, 167, 168)	2
6107	Oil, Bottle (21 oz) ISO 68 Hydraulic	4
6139	Lubricant, Anti-Seize (8 oz)	1
990036	Key (M8 x 7 x 40)	1



7022
7022.100

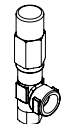

7595.0110

OPTIONAL PARTS AND ACCESSORIES

Part Number	Description	QTY
7022/ 7022.100	Regulator (Primary Pressure Control)	1
7590.1110/890702	Valve, Relief (Primary or Secondary Pressure Control)	1
9940.0110/9941.0110	Valve, Pop-Off (Secondary Pressure Control)	1
6073	Gauge, Pressure	1
6013	Dampener, Pulsation	1
30614	Assembly, Rail	1
26516	Protector, Shaft	1
76144	Kit, Oil Indicator (3/8" x 24") See Individual Data Sheet	1
34334	Kit, Oil Drain (3/8" x 24") See Individual Data Sheet	1
30696	Reverse Pliers	1



9941.0110



6073



6013

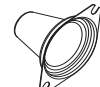

26516



6107



34334

⚠ CAUTIONS AND WARNINGS

All high-pressure systems require a primary pressure regulating device (e.g. regulator, unloader) and a secondary pressure relief device (e.g. pop-off valve, relief valve). Failure to install such relief devices could result in personal injury or damage to pump or property. Cat Pumps does not assume any liability or responsibility for the operation of a customer's high-pressure system. Read all CAUTIONS and WARNINGS before commencing service or operation of any high-pressure system. The CAUTIONS and WARNINGS are included in each Service Manual and with each Accessory Data sheet. CAUTIONS and WARNINGS can also be viewed online at www.catpumps.com/dynamic-literature/cautions-and-warnings or can be requested directly from Cat Pumps.

WARRANTY

View the Limited Warranty online at www.catpumps.com/literature/cat-pumps-limited-warranty