

DATA SHEET

35 FRAME PLUNGER PUMPS



Brass Model: 3520

Brass Flushed Model: 3520C

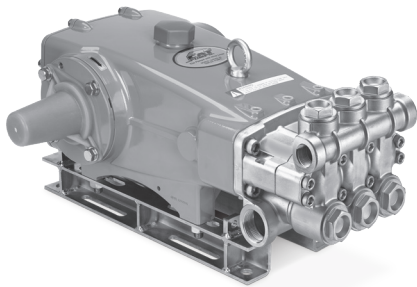

Model 3520 Shown
(Shaft protector included, mounting rails sold separately)

FEATURES

- Triplex plunger design ensures high efficiency and low pulsation.
- V-packings and low-pressure seals are completely lubricated and cooled by pumped liquid, greatly increasing service life.
- Model 3520C offers an external flush for high-temperature or low-lubricity liquids.
- Pump comes standard with NBR seals. Alternative seal materials are available for higher temperature or chemical compatibility.

SPECIFICATIONS	U.S. Measure	Metric Measure
Flow	25 gpm	94.6 lpm
Pump Pressure Range	100–2000 psi	6.9–138 bar
Pump RPM*	870 rpm	870 rpm
Inlet Pressure Range	Flooded to 70 psi	Flooded to 4.8 bar
Maximum Liquid Temp. (NBR)	160° F	71° C
Alternative seals available for higher temperatures up to 200° F		
Bore	1.260"	32 mm
Stroke	1.890"	48 mm
Crankcase Capacity	4.2 qts	4 l
Inlet Ports (2)	1½" NPT(F)	1½" NPT (F)
Flush Ports (2) "C"	¼" NPT (F)	¼" NPT (F)
Discharge Ports (2)	1" NPT (F)	1" NPT (F)
Shaft Diameter	1.378"	35 mm
Pulley Mounting	Either Side	Either Side
Weight	139 lbs	63 kg
Dimensions	23.86 x 18.11 x 9.72"	606 x 460 x 247 mm

*Pump minimum is 100 RPM.

ALTERNATIVE SEAL CONFIGURATION

MATERIAL	SUFFIX CODE	MAXIMUM TEMPERATURE	
NBR	—	160° F	(71° C)
FPM	.0110	180° F	(82° C)
EPDM	.0220	160° F	(71° C)
FFKM	.0770	200° F	(93° C)
STHT	.3400	190° F	(88° C)

See **Tech Bulletin 002** for inlet conditions and RPM at higher temperatures.

DETERMINING THE PUMP RPM	$\frac{\text{Rated gpm}}{\text{Rated rpm}} = \frac{\text{Desired gpm}}{\text{Desired rpm}}$
DETERMINING THE REQUIRED HP	$\text{hp (Electric Brake)} = \frac{\text{gpm} \times \text{psi}}{1460}$
DETERMINING MOTOR PULLEY SIZE	$\frac{\text{Motor Pulley OD}}{\text{Pump rpm}} = \frac{\text{Pump Pulley OD}}{\text{Motor rpm}}$

Refer to pump **Service Manual** for repair procedure and additional technical information.

PARTS LIST

ITEM	P/N	MATL	DESCRIPTION	QTY
	3520/C			
5	96049	S	Screw, HHC Sems (M10 x 25) (See Tech Bulletin 074)	8
8	134604	ALE	Cover, Bearing	2
9	815279	FBR	Shim, Split, 2-Piece	2
10	12398	NBR	O-Ring, Bearing Cover-70D	2
11	13296	NBR	Seal, Oil, Crankshaft	2
12	855049	S	Shim, Split, 2-Piece	0-2
15	29326	STL	Bearing, Roller	2
20	121467	TNM	Rod, Connecting Assembly (Includes: 21, 22, 23) (See Tech Bulletin 074)	3
21	126749	STCP R	Washer, Locking	3
22	126593	STCP R	Washer, Flat (M10.5)	6
23	122045	STZP	Screw, HH (M10 x 55)	6
25	29325	FCM	Crankshaft, Dual End (M48)	1
31	828710	PE	Protector, Oil Cap with Foam Gasket	1
32	43211	ABS	Cap, Oil Filler	1
33	14177	NBR	O-Ring, Oil Filler Cap-70D	1
34	126743	STCP R	Bolt, Eye (M12 x 1.75) (For Lifting Pump Only)	1
37	92241	PC	Gauge, Oil, Bubble with Gasket-80D (See Tech Bulletin 074)	1
38	44428	NBR	Gasket, Flat Oil Gauge-80D	1
40	125753	S	Screw, HHC Sems (M8 x 25) (See Tech Bulletin 074)	8
48	25625	STCP	Plug, Drain (1/4" x 19 BSP)	1
49	23170	NBR	O-Ring, Drain Plug-70D	1
50	45936	ALE	Cover, Rear (See Tech Bulletin 118)	1
51	16612	NBR	O-Ring, Cover-70D	1
53	134784	ALE	Crankcase Assembly (Includes: 54)	1
54	27488	S	Pins, Guide	2
56	27790	POP	Pan, Oil	1
59	92538	S	Screw, HHC Sems (M6 x 16)	2
64	43864	CM	Pin, Crosshead	3
65	† 45116	SSZZ	Rod, Plunger	3
69	126587	STCP R	Washer, Oil Seal	3
70	100488	NBR S	Seal, Oil, Crankcase	3
75	43865	S	Slinger, Barrier	3
88	45676	S	Washer, Keyhole (M16)	3
90	43957	CC	Plunger (M32 x 145)	3
95	† 89778	SS	Stud, Plunger Retainer (M10 x 135)	3
96	20189	PTFE	Backup Ring, Plunger Retainer	3
97	11345	NBR	O-Ring, Plunger Retainer-70D	3
98	44085	SS	Gasket, Retainer	3
99	† 44084	SS	Retainer, Plunger (M10) (See Tech Bulletin 074)	3
100	44119	PPG	Retainer, Seal	3
101	44106	—	Wick, Long Tab	3
104	43875	NBR	O-Ring, Inlet Adapter-70D	3
105	49741	BB	Adapter, Inlet	3
106	44098	NBR	Seal, Low-Pressure, with SS-Spring	3
107	43962	S	Washer	3
110	49464	BBCP R	Manifold, Inlet	1
	49464C	BBCP R	Manifold, Inlet, Flushed (Model 3520C)	1
112	11379	NBR	O-Ring, Inlet Manifold-70D	3
117	44585	S	Screw, HSH (M14 x 40) (See Tech Bulletin 074)	4
122	49744	BB	Spacer	3
123	12391	NBR	O-Ring, V-Packing Cylinder-70D	3
124	49742	BB	Cylinder, V-Packing	3
126	43963	BB	Adapter, Female	3
127	† 44608	STG	V-Packing	6
128	43965	BB	Adapter, Male	3
141	49743	SS	Spring, Coil	3
158	48362	D	Backup Ring, V-Packing Cylinder	3
159	48860	NBR	O-Ring, V-Packing Cylinder-90D	3
162	48363	D	Backup Ring, Valve Seat	6
163	26142	NBR	O-Ring, Seat-80D	6
164	44727	S	Seat, Stepped	6
166	43932	S	Valve	6
167	44109	SS	Spring	6
168	44728	PVDF	Retainer, Spring	6
170	44729	SS	Washer, Spring Retainer	6
171	44644	SS	Coil Spring (70 kg), Valve Plug	6
172	89827	NBR	O-Ring, Valve Plug-90D	6
173	48364	D	Backup Ring, Valve Plug	6
174	46444	FBB	Plug, Valve (See Tech Bulletin 074)	6
185	49465	BBCP R	Manifold, Discharge	1
188	89981	S	Screw, HSH (M12 x 70) (See Tech Bulletin 074)	8
250	855042	NY	Protector, Shaft with Two (2) Screws, Lockwashers and Washers	1

Bold print part numbers are unique to a particular pump model. Italics are optional items.

† Production Parts different from service parts. R Components comply with RoHS Directive. For additional technical information see www.catpumps.com/literature/tech-bulletins.

MATERIAL CODES (Not Part of Part Number): ABS=ABS Plastic AL=Aluminum ALE=Aluminum Epoxy BB=Brass BBCP=Brass/Chrome Plated CC=Ceramic CM=ChromeMoly

D=Acetal EPDM=Ethylene Propylene Diene Monomer F=Cast Iron FBR=Fiber FCM=Forged Chrome-moly FFKM=Perfluoroelastomer FPM=Fluorocarbon

NBR=Medium Nitrile (Buna-N) NBR S=Buna, Silicone Free NY=Nylon PC=Poly Carbonate PE=Polyethylene POP=Polypropylene

PPG=Glass Filled Polypropylene PTFE=Pure Polytetrafluoroethylene PVDF=Polyvinylidene Fluoride S=304SS SS=316SS

SFG=Special Blend FPM ST 2=Special PTFE 2 STG=Special Blend PTFE White STCP=Steel/Chrome Plated STL=Steel

STZP=Steel/Zinc Plated SSZZ=316SS/Zamak TNM=Special High Strength ZP=Zinc Plated

Optional Parts and Accessories and Service parts listed on page 3. Standard and optional Seal and Valve Kits listed on page 4.

EXPLODED VIEW

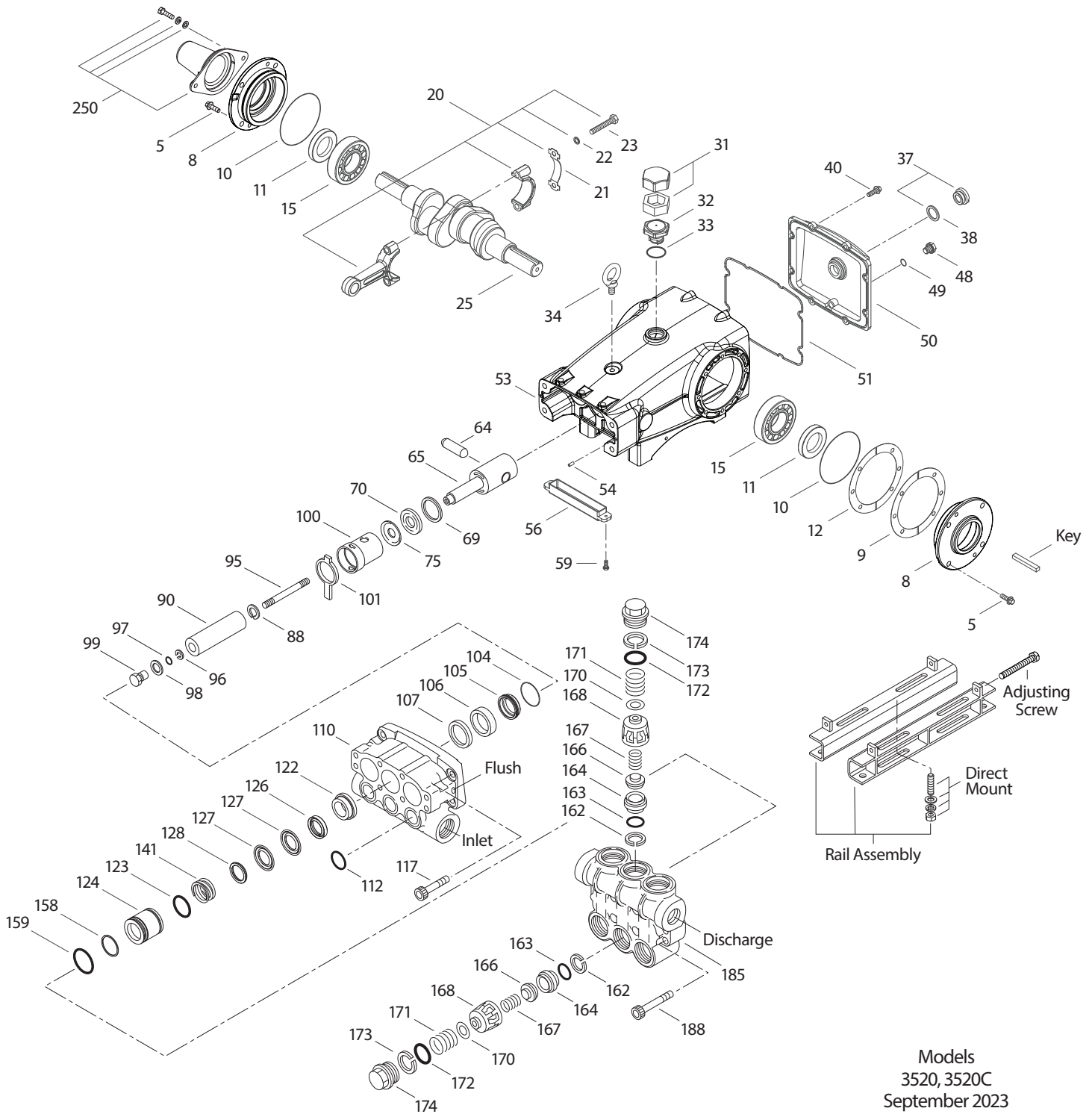

Models
3520, 3520C
September 2023

OPTIONAL PARTS AND ACCESSORIES

PART	DESCRIPTION	QTY
34021	Key (M10 x 8 x 70)	1
92674	Mount, Rail, Assembly (STZP R) (Includes: 34018)	1
34018	Mount, Direct (STZP R)	1
990013	Hub, "B", 35 mm (Not Shown)	1
80540	Screw, Adjusting (M12 x 100)	2
30278	Oiler (1 oz) (Not Shown)	3
34314	Kit, Oil Drain (3/8" x 48") (Not Shown)	1
819000	Assembly, Crankcase, Cast Iron Conversion	1

SERVICE PARTS

PART	DESCRIPTION	QTY
76841	Seal Kit – Standard NBR	1
34235	Valve Kit – Standard NBR	2
6100	Oil, Case (12 – 21 oz bottles) (Fill to Specified Crankcase Capacity Prior to Start-up)	1
6124	Gasket, Liquid (3 oz)	1
32273	Crankcase Oil Seal Removal and Installation Kit (Not Shown) (Includes: Oil Seals, Guide Tool, Screws, Washers, Driver)	1
30696	Reverse Pliers (Not Shown)	1
818473	Head, Complete with NBR Seals and O-Rings (Model 3520)	1

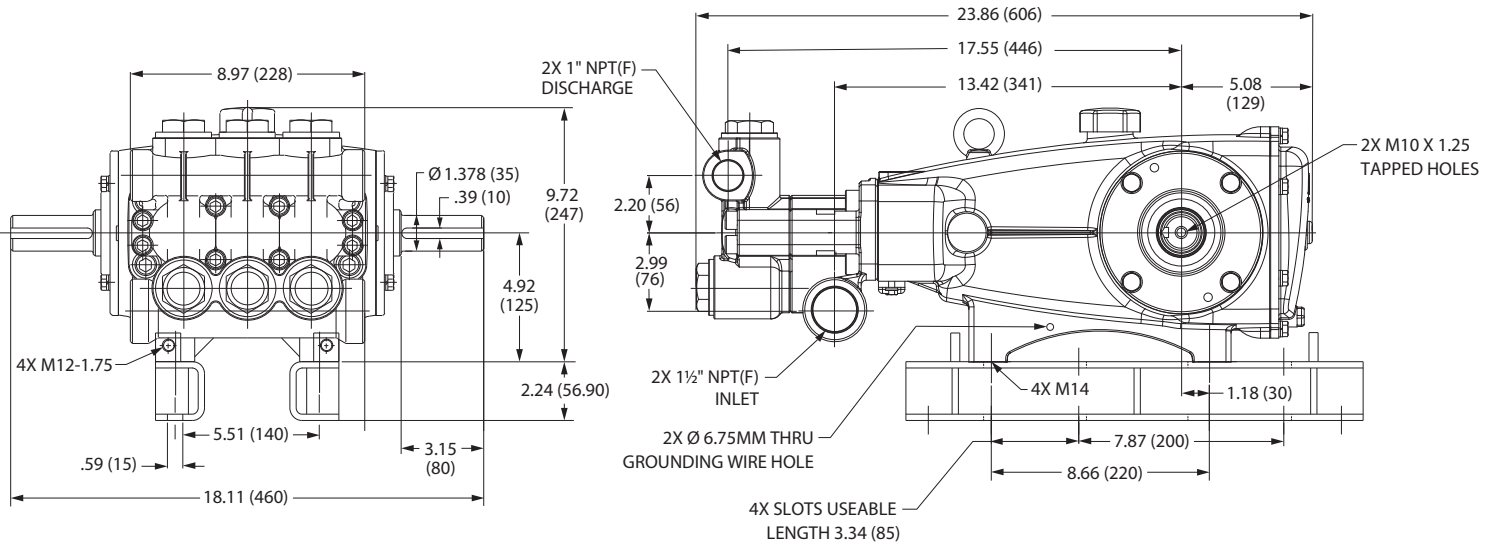

Model 3520

SEAL KITS One (1) seal kit required per pump

PUMP MODELS	NBR (STD)	FPM (.0110)	EPDM (.0220) ♦	FFKM (.0770)	STHT (.3400)
3520, 3520C	76841*	76842	76843*	76844*	76877

ITEM (Included in Seal Kits)						DESCRIPTION	QTY
97	11345	11375	701490	702961	11345	O-Ring, Plunger Retainer	3
104	43875	44826	701656	702977	43875	O-Ring, Inlet Adapter	3
106	44098	44827	48244	76298	76298	Seal, Low-Pressure, with SS-Spring	3
112	11379	14183	701491	702705	11379	O-Ring, Inlet Manifold	3
123	12391	13266	701657	703481	12391	O-Ring, V-Packing Cylinder	3
127	44608	44829	44608	44608	44608	V-Packing	6
158	48362	48362	48362	20464	48362	Backup Ring, V-Packing Cylinder	3
159	48860	20137	701492	703159	48860	O-Ring, V-Packing Cylinder	3

♦ Silicone oil/grease required *Review material codes for individual items (STG generally may be used as alternative)

VALVE KITS Two (2) valve kits required per pump

PUMP MODELS	NBR (STD)	FPM (.0110)	EPDM (.0220) ♦	FFKM (.0770)	STHT (.3400)
3520, 3520C	34235	31955	31952	76617	34235

ITEM (Included in Valve Kits)						DESCRIPTION	QTY
162	48363	48363	48363	44614	48363	Backup Ring, Valve Seat	3
163	26142	14330	701493	702808	26142	O-Ring, Valve Seat	3
164	44727	44612	44612	44612	44727	Seat, Stepped	3
166	43932	44108	44108	44108	43932	Valve	3
167	44109	44109	44109	44109	44109	Spring	3
168	44728	44728	44728	44728	44728	Retainer, Spring	3
170	44729	44729	44729	44729	44729	Washer, Spring Retainer	3
172	89827	11747	701494	703169	89827	O-Ring, Valve Plug	3
173	48364	48364	48364	20388	48364	Backup Ring, Valve Plug	3

♦ Silicone oil/grease required

⚠ CAUTIONS AND WARNINGS

All high-pressure systems require a primary pressure regulating device (e.g. regulator, unloader) and a secondary pressure relief device (e.g. pop-off valve, relief valve). Failure to install such relief devices could result in personal injury or damage to pump or property. Cat Pumps does not assume any liability or responsibility for the operation of a customer's high-pressure system. Read all CAUTIONS and WARNINGS before commencing service or operation of any high-pressure system. The CAUTIONS and WARNINGS are included in each Service Manual and with each Accessory Data sheet. CAUTIONS and WARNINGS can also be viewed online at www.catpumps.com/dynamic-literature/cautions-and-warnings or can be requested directly from Cat Pumps.

WARRANTY

View the Limited Warranty online at www.catpumps.com/literature/cat-pumps-limited-warranty