

# DATA SHEET

## 150 FRAME R-SERIES PLUNGER PUMP



The Pumps with Nine Lives

### Duplex Stainless Steel Model: **157R060**

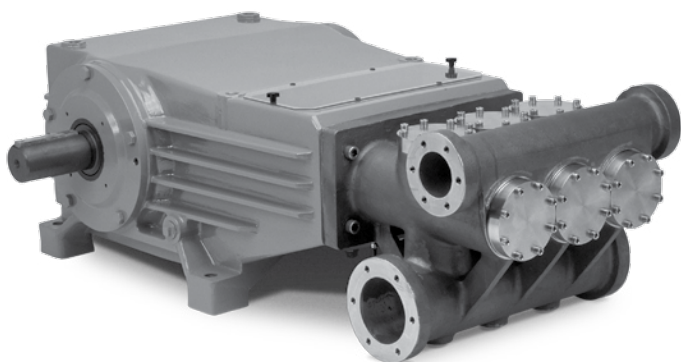

Model 157R060 Shown

#### FEATURES

- Triplex design delivers high efficiency and low pulsation.
- Durable dual V-Packings are lubricated and cooled by pumped liquid.
- Pre-Set Lo-Pressure Seals provide secondary protection against external leaks and require no packing adjustment.
- Special high density, polished, concentric plungers provide a true wear surface and extended seal life.
- Specially formulated Seals and V-Packings offer unmatched performance and extended seal life.
- Ceramic plungers, Seals and V-Packings are serviceable from the top of the crankcase permitting easy in-field servicing.

#### SPECIFICATIONS

	U.S. Measure	Metric Measure
Flow	100 gpm	378 lpm
Pressure Range*	100 to 2700 psi	6.9 to 186 bar
Pump RPM**	310 rpm	310 rpm
Inlet Pressure Range	Flooded to 50 psi	Flooded to 3.5 bar
Maximum Temperature	160° F	71° C
Bore	2.375"	60.3 mm
Stroke	5.91"	150 mm
Crankcase Capacity	22.4 gal	85 l
Lubrication	Splash	Splash
Inlet Ports (2) (Flange Required)	6.0"	150 mm
Discharge Ports (2) (Flange Required)	4.0"	100 mm
Shaft Diameter	3.937"	100 mm
Shaft Length	8.15"	207 mm
Weight	3087 lbs.	1400 kg
Dimensions	68.9 x 42.1 x 22"	1750 x 1069 x 560 mm

#### API

Flow	87 gpm	329 lpm
Barrels Per Day (U.S. Petrol)	2983 bbl/d	—
Pressure Range*	100 to 2700 psi	6.9 to 186 bar
Maximum RPM**	270 rpm	270 rpm

\* Relief pressure should be set at maximum 10% over system pressure.

\*\*Pump minimum is 75 RPM.

#### ELECTRIC HORSEPOWER REQUIREMENTS

MODELS	FLOW		PRESSURE					PUMP RPM
			psi 1000	psi 1500	psi 2000	psi 2500	psi 2700	
			gpm	lpm	bar 69	bar 103	bar 138	
<b>157R060</b>	100	378	69	103	137	172	185	310
<b>157R060 API</b>	87	329	59	89	118	148	159	270

$$\frac{\text{DETERMINING THE PUMP R.P.M.}}{\text{Rated rpm}} = \frac{\text{Rated gpm}}{\text{"Desired" gpm}}$$

$$\frac{\text{DETERMINING THE REQUIRED H.P.}}{\text{(Electric Brake)}} = \frac{\text{Hp}}{\frac{\text{gpm x psi}}{1460}}$$

$$\frac{\text{DETERMINING MOTOR PULLEY SIZE}}{\text{Pump rpm}} = \frac{\text{Motor Pulley O.D.}}{\text{Pump Pulley O.D.}}$$

See complete Drive Packages [Incls: Pulleys, Belts, Hubs, Key] Tech Bulletin 003.  
Refer to pump **Service Manual** for repair procedure and additional technical information.

# PARTS LIST

ITEM	PART NUMBER	MATL	DESCRIPTION	QTY
2	890602	STL	Key (M28x16x170)	1
3	891238	STL	Screw, Grub (M20x20)	4
4	891275	SS	Plate, Serial No. (Not Shown)	1
5	891228	STL	Screw, HH (M20x60)	10
8	891235	F	Cover, Bearing	1
10	890215	FPM	O-Ring, Bearing Cover - 70D	2
11	890270	NBR	Seal, Oil	1
12	890230	POP	Shim Set	1
15	891240	STL	Bearing, Roller	2
20	891360	MZ	Rod, Connecting Assy (Incls: 2-Sleeves, 2-Washers, 2-Screws) [03/09]	3
25	891361	CM	Crankshaft, Single End [03/09]	1
30	891230	F	Cover, Bearing, Blind	1
32	891234	NY	Cap, Filler w/Gasket	1
35	891226	SS	Rivet, (M2.9x6.5) (Not Shown)	6
36	891202	SS	Nameplate (Not Shown)	1
37	891233	—	Gauge, Oil Bubble w/Gasket	1
40	890295	STL	Screw, HH (M16x50)	10
42	891237	SS	Washer, Flat (M8)	6
43	891225	SS	Screw, HSH (M8x15)	6
45	891243	SS	Screw, Grub (M10x20) (Not Shown)	4
48	891232	AL	Plug, HH Drain	1
50	891250	F	Cover, Rear	1
52	891244	STL	Screw, Grub (M16)	2
53	891272	F	Crankcase	1
55	891203	SS	Pin, Guide (M16x50) (Not Shown)	2
60	891201	PC	Cover, Rod Box	1
61	891224	SS	Screw, HSH (M10x15)	2
62	891282	STL	Pin, Roll (M6x25)	3
63	891280	F	Crosshead	3
64	891281	STL	Pin, Crosshead	3
65	891261	SS	Rod, Plunger	3
66	891236	RBR	Grommet, Cover	6
70	890275	PTFE	Seal, Oil - 70D [07/05]	3
77	890216	FPM	O-Ring, Carrier	3
80	891255	SS	Carrier, Oil Seal [07/05]	3
88	890347	SS	Insert, Plunger	3
90	890415	CC	Plunger (M60.3x262) (See Tech Bulletin 115)	3
95	890368	SS	Stud, (M20 x 200)	3
96	890336	PTFE	Back-Up Ring - 70D	3
97	890335	NBR	O-Ring - 70D	3
98	890348	SSD	Gasket, Plunger Retainer	3
99	890312	SSD	Retainer, Plunger	3
102	890372	NAB	Adjuster, Packing	3
104	890203	NBR	O-Ring, Spacer - 70D	3
	890227	FPM	O-Ring, Spacer - 70D	3
105	890580	SSD	Case, Seal [01/11]	3
106	890565	NBR	Seal, LPS	3
	890561	FPM	Seal, LPS	3
118	890389	SSD	Plug, [1/16"NPT(M)]	3
124	890352	SSD	Housing, Seal	3
127	890520	SFTK	V-Packing, Set	3
129	890202	NBR	O-Ring, Housing - 70D	3
	890228	FPM	O-Ring, Housing - 70D	3
130	890591	PTFE	Back-up-Ring, Housing	6
145	890589	D	Ring, Sealing	3
164	890259	SS	Seat, QV	6
166	890250	SSSS	Valve, QV	6
167	890319	SS	Spring	6
171	890300	SS	Nut, QV	6
172	890225	NBR	O-Ring, Plug - 90D	6
	890245	FPM	O-Ring, Plug - 70D	6
174	890292	SSD	Plug, Valve, Inlet	3
175	890222	STTC	Screw, HSH (M12x55)	72
176	891294	SSD	Plug, Valve, Discharge [09/02]	3
185	892009	SSD	Head, Manifold [09/02]	1
188	891273	STTC	Screw, HSH (M24x100)	8
200	892016	POP	Barb, 1/4" NPT x 1/4" Barb	6
201	892018	RBR	Hose, 9"x1/4" LOP	3
202	892019	SS	Clamp, 1/4" Hose	6
290	890999	—	Loctite® 641, 10ML (Not Shown)	1
	890997	—	Loctite® 243, 10ML (Not Shown)	1
295	891101	—	Drive-end w/o Plungers (Includes: Items 2 thru 80, 349, 351, 352)	1
296	890395	SSD	Assembly, Plunger (Incls: 88, 90, 95, 96, 97, 98, 99) (See Tech Bulletin 115)	3
297	891151	SSD	Assembly, Head (Incls: 164 thru 202) [09/02]	1
300	890036	NBR*	Kit, Seal (Incls: 70,77,96,97,104,106,127) [07/05]	1
310	890018	NBR	Kit, Valve w/o Seat (Incls: 166,167,171,172,290)	2
	890019	NBR	Kit, Valve (Incls: 164,166,167,171,172,290)	2
349	891231	SS	Screw, HSH (M3x5)	2

# EXPLODED VIEW

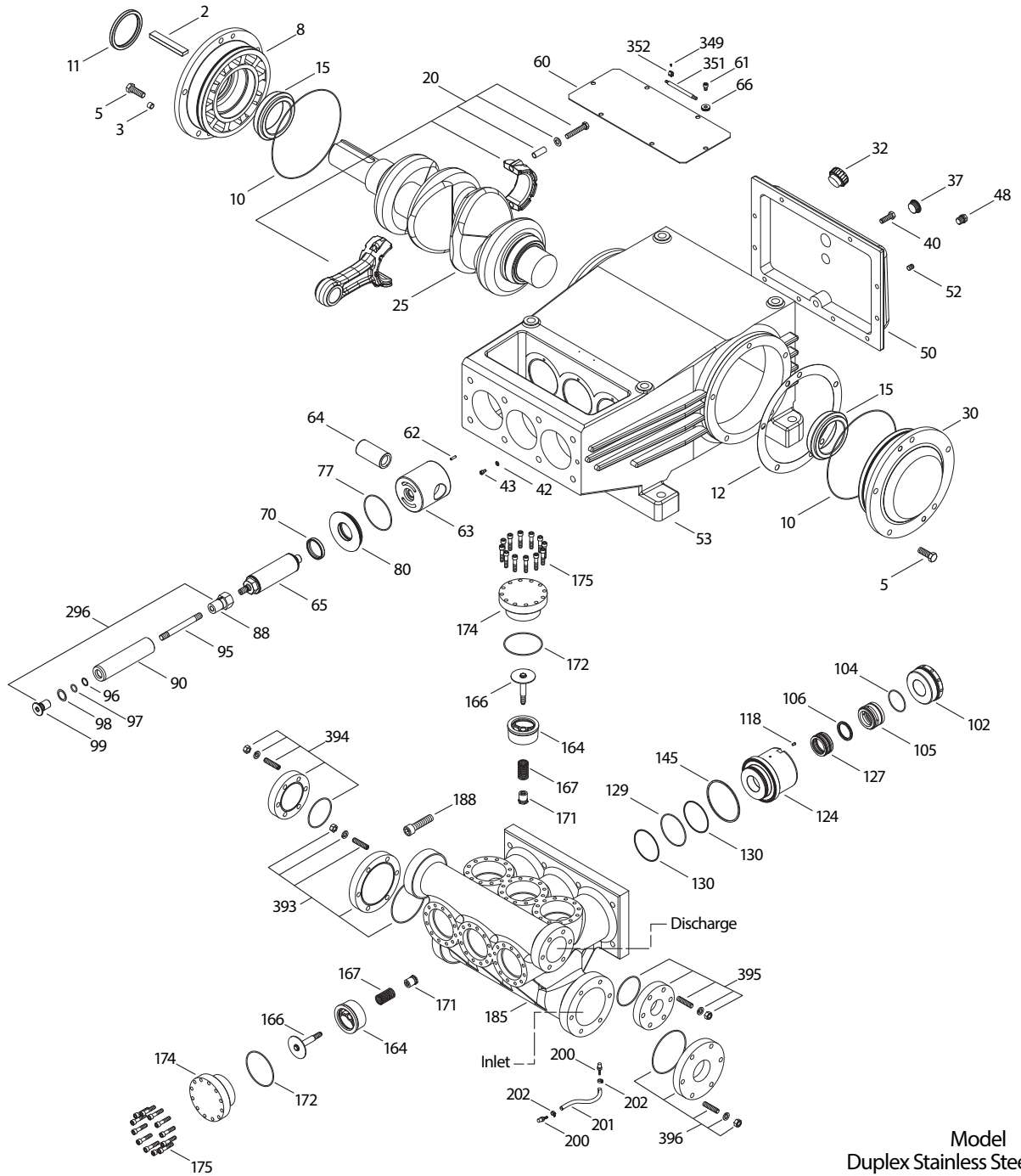

Model  
Duplex Stainless Steel 157R060  
August 2016

ITEM	PART NUMBER	MATL	DESCRIPTION	QTY
351	890990	SS	<i>Tool, Packing Adjuster</i>	1
352	890998	STZP	<i>Clip, Tool</i>	2
390	719500	SS	<i>C.A.T. (Inlet pressure stabilizer for RO and boosted inlet applications)</i>	1
	890700	SS	<i>Valve, Relief 2"</i>	1
	701550	SS	<i>Dampener, Pulsation (NBR Bladder)</i>	1
393	892092	SS	<i>Flange, Blank, Inlet (Specify Flange Type When Ordering)</i>	1
394	892093	SS	<i>Flange, Blank, Discharge (Specify Flange Type When Ordering)</i>	1
395	892096	SS	<i>Flange, Discharge 2" NPT (Specify Flange Type When Ordering)</i>	1
396	892088	SS	<i>Flange, Inlet 3" NPT (Specify Flange Type When Ordering)</i>	1
—	6119	—	<i>Lubricant, Antiseize (2oz.) (See Tech Bulletin 095)</i>	1
—	6116	—	<i>Oil, Drum (16 gal.) ISO 100 Mult-viscosity Hydraulic (Fill to specified crankcase capacity prior to start-up)</i>	1-2

Loctite is a registered trademark of Henkel Corporation.

View Tech Bulletins 002, 043, 115. [ ] Date of latest production change. *italics are optional items.* \*Review material codes for individual items (SFTK generally may be used as alternate).  
 MATERIAL CODES (Not Part of Part Number): AL=Aluminum CC=Ceramic CM=Chrome-Moly D=Acetal F=Cast Iron FPM=Fluorocarbon MZ=Mazak NAB=Nickel Aluminum Bronze  
 NBR=Medium Nitrile (Buna-N) NY=Nylon PC=Polycarbonate POP=Polypropylene PTFE=Pure Polytetrafluoroethylene RBR=Rubber SFTK=Polytetrafluoroethylene/Aramid Fiber Blend  
 SS=316SS SSSS=404SS SSD=Duplex Stainless STL=Steel STTC=Steel PTFE Coated STZP=Steel/Zinc Plated

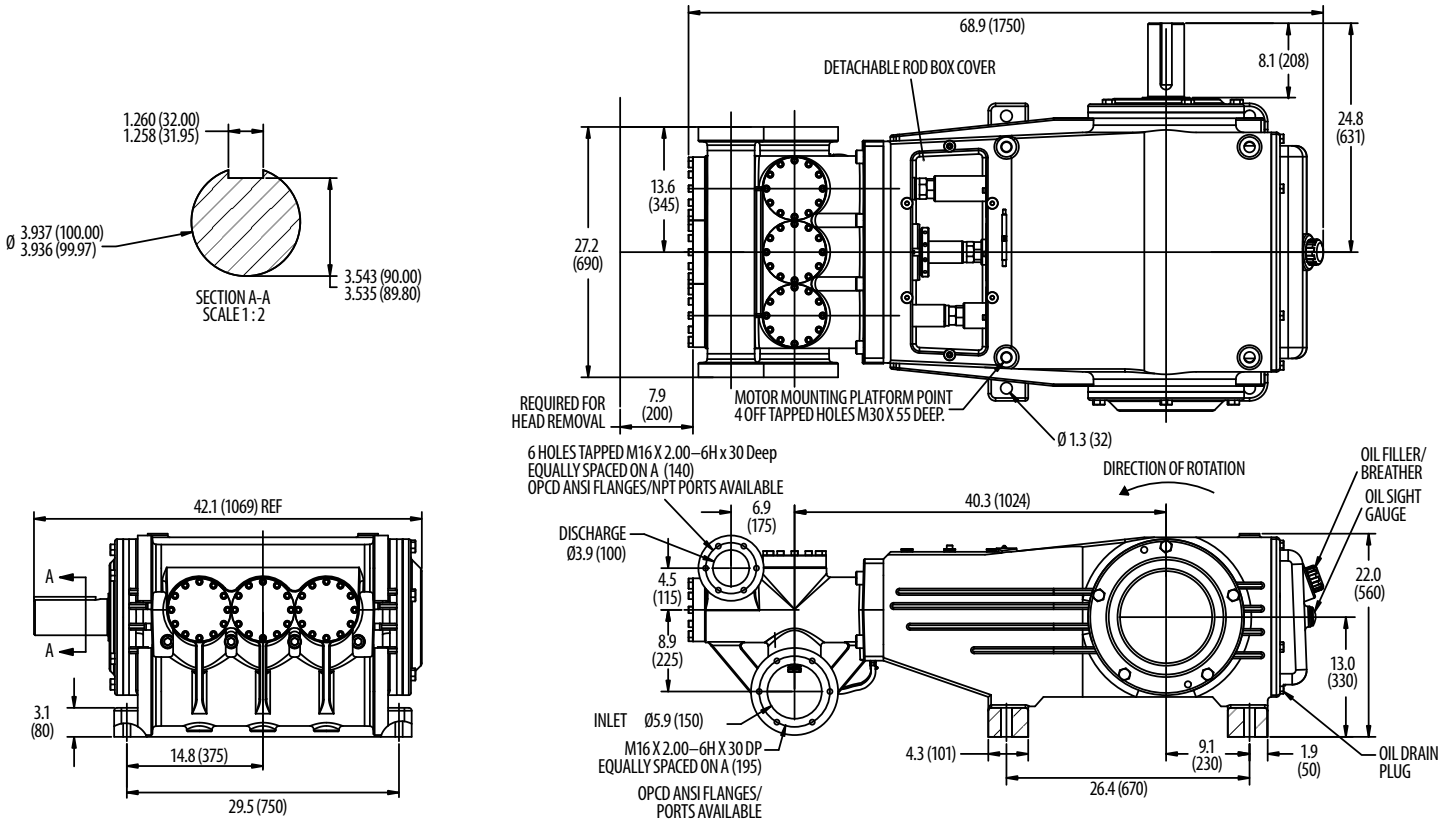

### ⚠ CAUTIONS AND WARNINGS

All High Pressure Systems require a primary pressure regulating device (i.e. regulator, unloader) and a secondary pressure relief device (i.e. pop-off valve, relief valve). Failure to install such relief devices could result in personal injury or damage to pump or property. Cat Pumps does not assume any liability or responsibility for the operation of a customer's high pressure system.

Read all CAUTIONS and WARNINGS before commencing service or operation of any high pressure system. The CAUTIONS and WARNINGS are included in each service manual and with each Accessory Data sheet. CAUTIONS and WARNINGS can also be viewed online at [www.catpumps.com/cautions-warnings](http://www.catpumps.com/cautions-warnings) or can be requested directly from Cat Pumps.

### WARRANTY

View the Limited Warranty on-line at [www.catpumps.com/warranty](http://www.catpumps.com/warranty).



### CAT PUMPS

1681 - 94TH LANE N.E. MINNEAPOLIS, MN 55449-4324  
PHONE (763) 780-5440 — FAX (763) 780-2958  
e-mail: [techsupport@catpumps.com](mailto:techsupport@catpumps.com)  
[www.catpumps.com](http://www.catpumps.com)