

15 Frame Plunger Pump

**Standard Brass
Model**

1540

FEATURES

Superior Design

- Triplex plunger design provides smoother liquid flow.
- Hi-Pressure seals are completely lubricated and cooled by the liquid being pumped.
- Inlet and discharge valve assemblies interchange for easier maintenance.
- Lubricated Lo-Pressure Seals provide double protection against external leakage.
- Oil bath crankcase assures optimum lubrication.
- Close tolerance concentricity of the ceramic plunger maximizes seal life.

Quality Materials

- Precision design 304 stainless steel valves and seats are hardened and polished for ultimate seating and extended valve life.
- Forged Brass manifolds are strong and corrosion resistance.
- Special concentric, high-density, polished, solid ceramic plungers provide a true wear surface and extended seal life.
- Specially formulated, CAT PUMP exclusive, Hi-Pressure seals offer unmatched performance and seal life.
- Die cast aluminum crankcase provides high strength, minimum weight and precision tolerance control.
- Chrome-moly crankshaft gives unmatched strength and surface hardness.
- Oversized crankshaft bearings with greater loading capacity mean longer bearing life.

Easy Maintenance

- Wet-end is easily serviced without entering crankcase, requiring less time and effort.
- Preset packings mean no packing gland adjustment is necessary, reducing maintenance costs.

⚠ WARNING

All systems require both a primary pressure regulating device (i.e., regulator, unloader) and a secondary pressure safety relief device (i.e., pop-off valve, safety valve). Failure to install such relief devices could result in personal injury or damage to the pump or to system components. CAT PUMPS does not assume any liability or responsibility for the operation of a customer's high pressure system.

SPECIFICATIONS

	U.S. Measure	Metric Measure
Flow	18.0 GPM	(68 L/M)
Pressure Range.....	100 to 1200 PSI	(7 to 85 BAR)
RPM	1100 RPM	(1100 RPM)
Inlet Pressure Range	Flooded to 70 PSI	(Flooded to 4.9 BAR)
Bore.....	1.181"	(30 mm)
Stroke.....	1.181"	(30 mm)
Crankcase Capacity	42 oz.	(1.26 L)
Maximum Liquid Temperature	140°F	(60°C)
Above 130°F call CAT PUMPS for inlet conditions and elastomer recommendations.		
Inlet Ports (2)	1" NPTF	(1" NPTF)
Discharge Ports (2).....	3/4" NPTF	(3/4" NPTF)
Pulley Mounting	Either Side	(Either Side)
Shaft Diameter	1.181"	(30 mm)
Weight.....	42.6 lbs.	(21 kg)
Dimensions.....	14.57 x 13.0 x 7.20"	(370 x 330 x 183 mm)

ELECTRIC HORSEPOWER REQUIREMENTS

FLOW		PRESSURE			RPM
		PSI 800	PSI 1000	PSI 1200	
U.S. GPM	L/M	BAR 55	BAR 70	BAR 85	
18	68	9.9	12.3	14.8	1100
15	57	8.2	10.3	12.3	917

DETERMINING THE PUMP R.P.M.	$\frac{\text{Rated G.P.M.}}{\text{Rated R.P.M.}}$	=	$\frac{\text{"Desired" G.P.M.}}{\text{"Desired" R.P.M.}}$
DETERMINING THE REQUIRED H.P.	$\frac{\text{GPM} \times \text{PSI}}{1460}$	=	Electric Brake H. P. Required
DETERMINING MOTOR PULLEY SIZE	$\frac{\text{Motor Pulley O.D.}}{\text{Pump R.P.M.}}$	=	$\frac{\text{Pump Pulley O.D.}}{\text{Motor R.P.M.}}$

See complete Drive Packages [Incls: Pulleys, Belts, Hubs, Key] Tech Bulletin 003.
Refer to pump **Service Manual** for repair procedure, additional technical information and **pump warranty**.

“Customer confidence is our greatest asset”

PARTS LIST

ITEM	P/N	MATL	DESCRIPTION	QTY
2	990036	STL	Key (M8x7x40) Use w/30059 and 990012	1
—	30067	STL	Key (M8x7.5x25) Use w/30059 "H" Hub	1
5	92538	S	Screw, Sems HHC (M6x16)	8
8	48929	AL	Cover, Bearing	2
10	11340	NBR	O-Ring, Bearing Cover - 70D	2
11	43495	NBR	Seal, Oil, Crankshaft - 70D	2
15	47068	STL	Bearing, Roller	2
20	48600	TNM	Rod, Connecting Assembly	3
25	43494	FCM	Crankshaft, Dual-End (M30)	1
31	828710	—	Protector, Oil Cap	1
32	43211	ABS	Cap, Oil Filler	1
33	14177	NBR	O-Ring, Filler Cap - 70D	1
37	92241	—	Gauge, Oil, Bubble w/Gasket - 80D	1
38	44428	NBR	Gasket, Flat, Oil Gauge - 80D	1
40	92542	S	Screw, Sems HHC (M6x20)	4
48	25625	STCP	Plug, Drain (1/4"x19BSP)	1
49	23170	NBR	O-Ring, Drain Plug - 70D	1
50	43491	AL	Cover, Rear	1
51	44834	NBR	O-Ring, Rear Cover - 70D	1
53	48925	AL	Crankcase	1
64	43507	CM	Pin, Crosshead	3
65	48933	SHS	Rod, Plunger (Off Center)	1
65	48931	SHS	Rod, Plunger (Center)	2
69	48935	NBR	Washer, Oil Seal	3
70	43500	NBR	Seal, Oil Crankcase - 80D	3
75	48937	S	Slinger, Barrier	3
90	48938	CC	Plunger, Ceramic (M30x65)	3
98	46730	NBR	Washer, Seal - 90D	3
99	48201	SSL	Retainer, Plunger	3
100	48936	PVDF	Retainer, Seal	3
106	49067	NBR	Seal, LPS w/SS-Spg	3
110	48940	FBB	Manifold, Inlet	1
112	123903	NBR	O-Ring, Inlet Manifold - 90D	3
117	49044	S	Screw, HSH (M10x25)	4
125	48944	SNG	Seal, HPS w/S	3
155	123903	NBR	O-Ring, Spacer - 90D	6
157	48946	BB	Spacer, HPS	3
163	26143	NBR	O-Ring, Seat - 80D	6
164	48951	S	Seat	6
166	48686	SSL	Valve	6
167	48687	SS	Spring, Valve	6
168	48994	PVDF	Retainer, Spring	6
170	123764	S	Washer, Spring Retainer	6
172	17629	NBR	O-Ring, Valve Plug - 80D	3
174	48952	FBB	Plug, Valve	3
185	48948	FBB	Manifold, Discharge	1
188	87952	S	Screw, HSH (M10x55)	10
250	30764	NY	Protector, Shaft	1
260	30613	STZP	Rail, Angle Assy (Incls: 30635,30903,30912,30921)	1
269	30206	F	Pulley (10") [See Drive Packages, Tech Bulletin 003]	1
270	30059	STL	Hub, "H", M30 (Keyway M8) [See Drive Packages, Tech Bulletin 003]	1
—	990012	STL	Hub, "B", M30 (Keyway M8) [See Drive Packages, Tech Bulletin 003]	1
283	34334	—	Kit, Oil Drain	1
290	6104	—	Sealant, Hylomar (1 oz.)	1
299	816863	FBB	Head, Complete	1
300	31770	NBR	Kit, Seal (Incls: 98,106,112,125,155)	1
310	31775	NBR	Kit, Valve (Incls: 163,164,166,167,168,170,172)	2
—	6100	—	Oil, Case (12 Bottles) ISO 68 Multi-viscosity Hydraulic (Fill to specified crankcase capacity prior to start-up)	1

Italics are optional items. See Tech Bulletins 002, 003, 024, 035, 036, 043, 053, 074, 077 and 083 for additional information.
MATERIAL CODES (Not Part of Part Number): ABS=ABS Plastic AL=Aluminum BB=Brass CC=Ceramic CM=Chrome-moly
F=Cast Iron FBB=Forged Brass FCM=Forged Chrome-moly NBR=Medium Nitrile (Buna-N) NY=Nylon
PVDF=Polyvinylidene Fluoride S=304SS SHS=304SS/High Strength SS=316SS SSL=316SS/Low Carbon
SNG=Special Blend (Buna) STCP=Steel/Chrome Plated STL=Steel STZP=Steel/Zinc Plated TNM=Special High Strength

EXPLODED VIEW

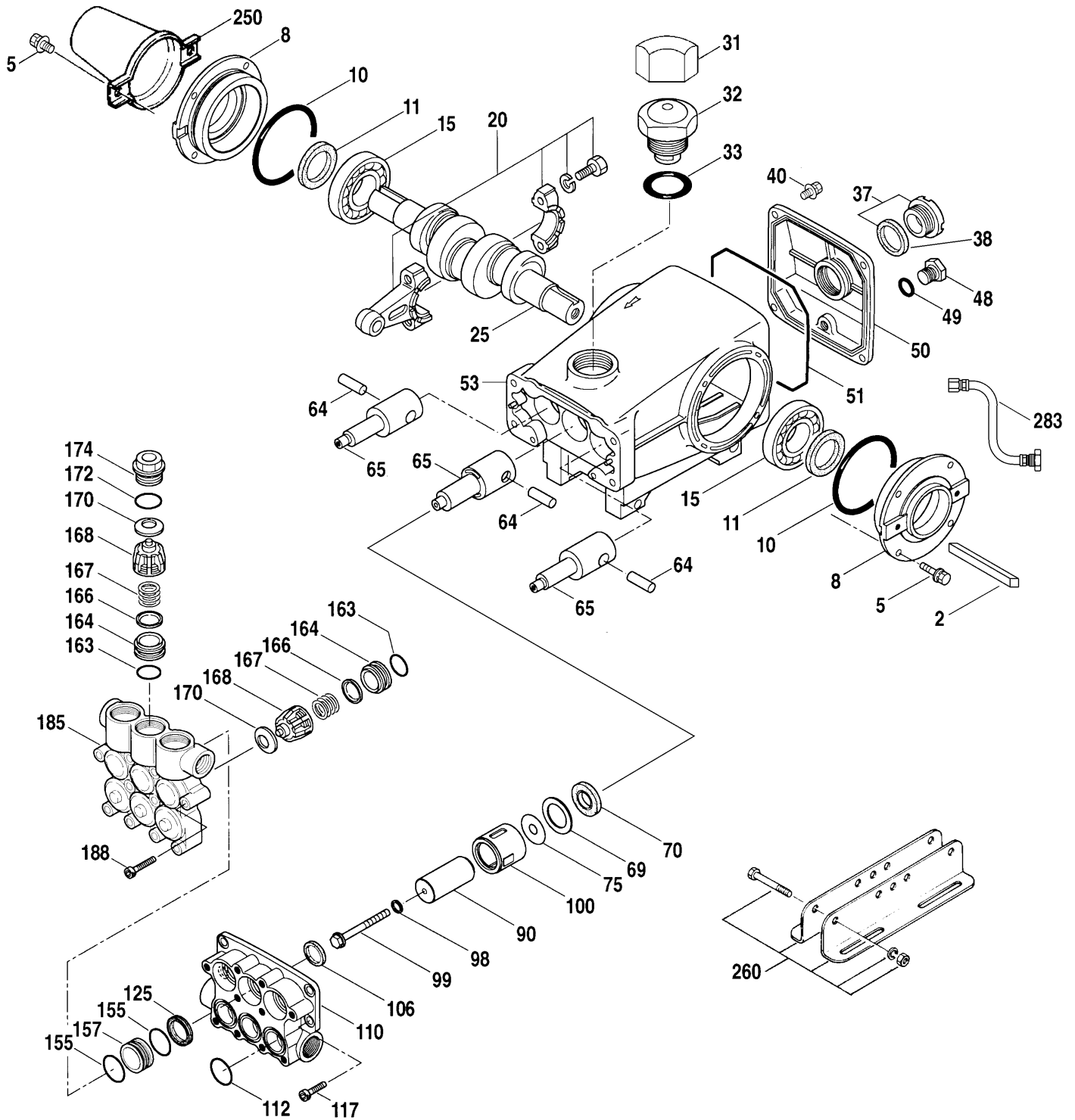

Model
Standard - 1540
August 2005

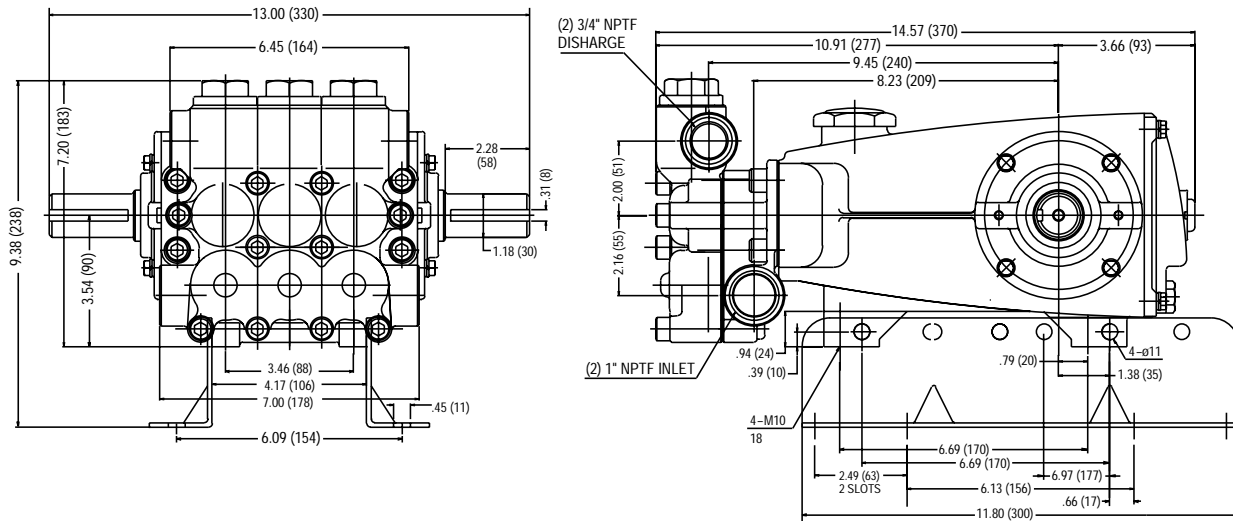

Model 1540

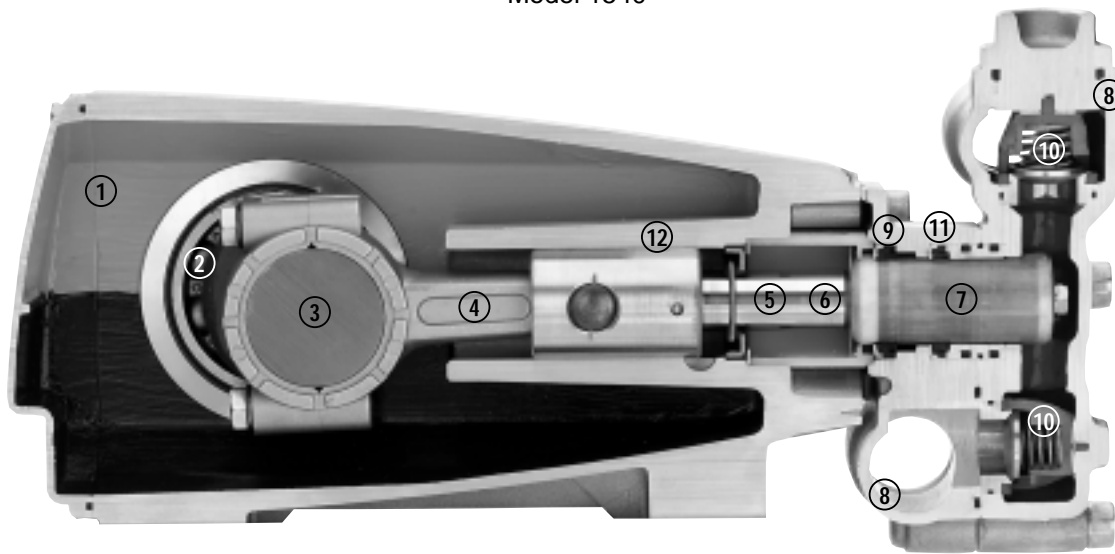

- 1 Die cast aluminum **crankcase** means high strength, light weight, and excellent tolerance control.
- 2 Oversized crankshaft **bearings** provide extended bearing life and pump performance.
- 3 Chrome-moly **crankshaft** provides unmatched strength and surface hardness for long life.
- 4 Matched oversized TNM **connecting rods** noted for superior tensile strength and bearing quality.

- 5 Special stainless steel **plunger rods** with high strength crossheads for longevity and corrosion resistance.
- 6 The stainless steel **slinger** provides back-up protection for the crankcase seal, keeping pumped liquids out of the crankcase.
- 7 Special concentric, high-density, polished, solid ceramic **plungers** provide a true wear surface and extended seal life.
- 8 **Manifolds** are a high strength forged brass for long-term, continuous duty.
- 9 100% wet **seal** design adds to service

- life by allowing pumped liquids to cool and lubricate on both sides of seals.
- 10 Stainless steel **valves, seats and springs** provide corrosion-resistance, ultimate seating and extended life.
- 11 Specially formulated, CAT PUMP exclusive, **Hi-Pressure Seals** offer unmatched performance and seal life.
- 12 **Crossheads** are 360° supported for uncompromising alignment.

Products described hereon are covered by one or more of the following U.S. patents 3558244, 3652188, 3809508, 3920356, 3930756 and 5035580

World Headquarters
CAT PUMPS
 1681 - 94th Lane N.E. Minneapolis, MN 55449-4324
 Phone (763) 780-5440 — FAX (763) 780-2958
 e-mail: techsupport@catpumps.com
 www.catpumps.com

International Inquiries
 FAX (763) 785-4329
 e-mail: intlsales@catpumps.com



CAT PUMPS (U.K.) LTD.
 1 Fleet Business Park, Sandy Lane, Church Crookham, Fleet
 Hampshire GU52 8BF, England
 Phone Fleet 44 1252-622031 — Fax 44 1252-626655
 e-mail: sales@catpumps.co.uk

N.V. CAT PUMPS INTERNATIONAL S.A.
 Heiveldekens 6A, 2550 Kontich, Belgium
 Phone 32-3-450.71.50 — Fax 32-3-450.71.51
 e-mail: cpi@catpumps.be www.catpumps.be

CAT PUMPS DEUTSCHLAND GmbH
 Buchwiese 2, D-65510 Idstein, Germany
 Phone 49 6126-9303 0 — Fax 49 6126-9303 33
 e-mail: catpumps@t-online.de www.catpumps.de