

Electric motor must be purchased separately.

FEATURES

- Triplex plunger design provides a smooth liquid flow.
- Specially formulated Hi-Pressure Seals and concentrically ground ceramic plungers assure maximum seal life.
- Stacked Stainless steel valve design for long life and easy servicing.
- Ultimate compact, direct-drive unit for maximum portability.
- Standard Integral Regulator with built-in by-pass assures system pressure control and pump protection.

COMMON SPECIFICATIONS

Inlet Pressure Range	Flooded to 60 PSI	(Flooded to 4 Bar)
Bore	0.630"	(16 mm)
Max. Liquid Temperature	140° F	(60° C)
Crankcase Capacity	8.5 oz.	(0.25 L)
Inlet Ports (1)	3/8" NPTF	(3/8" NPTF)
Discharge Port (1)	3/8" NPTM	(3/8" NPTM)
Shaft Diameter	5/8"	(15.8 mm)
Weight	10.7 lbs.	(4.9 kg)
Dimensions	7.75 x 7.12 x 6.29"	(197 x 180 x 160 mm)

NOTE: 3450 RPM models with 1725 RPM motor deliver half original flow.

⚠ WARNING

All systems require both a primary pressure regulating device (i.e., regulator, unloader) and a secondary pressure safety relief device (i.e., pop-off valve, safety valve). Failure to install such relief devices could result in personal injury or damage to the pump or to system components. CAT PUMPS does not assume any liability or responsibility for the operation of a customer's high pressure system.

Direct-Drive Misting Plunger Pumps

1725 RPM Model 2DX05ELS.MIST

3450 RPM Models 2DX15ES.MIST
2DX20ES.MIST
2DX27ES.MIST
2DX30ES.MIST

SPECIFICATIONS

	U.S. Measure	Metric Measure	U.S. Measure	Metric Measure
MODEL	2DX05ELS.MIST		2DX15ES.MIST	
Flow	0.5 GPM	(1.89 L/M)	1.5 GPM	(5.7 L/M)
Max. Discharge Pressure	2000 PSI	(140 BAR)	2000 PSI	(140 BAR)
Max. RPM	1725 RPM	(1725 RPM)	3450 RPM	(3450 RPM)
Stroke	0.078"	(2.0 mm)	0.118"	(3.0 mm)
MODEL	2DX20ES.MIST		2DX27ES.MIST	
Flow	2.0 GPM	(7.6 L/M)	2.7 GPM	(10.2 L/M)
Max. Discharge Pressure	2000 PSI	(140 BAR)	2000 PSI	(140 BAR)
Max. RPM	3450 RPM	(3450 RPM)	3450 RPM	(3450 RPM)
Stroke	0.157"	(4.0 mm)	0.220"	(5.6 mm)
MODEL	2DX30ES.MIST			
Flow	3.0 GPM	(11.4 L/M)		
Max. Discharge Pressure	1500 PSI	(105 BAR)		
Max. RPM	3450 RPM	(3450 RPM)		
Stroke	0.244"	(6.2 mm)		

ELECTRIC HORSEPOWER REQUIREMENTS

MODEL	FLOW		PRESSURE				RPM
	U.S. GPM	L/M	PSI 1000 BAR 70	PSI 1200 BAR 85	PSI 1500 BAR 105	PSI 2000 BAR 140	
2DX05ELS.MIST	0.5	1.89	0.34	0.41	0.51	0.68	1725
2DX15ES.MIST	1.5	5.7	1.03	1.23	1.54	2.05	3450
2DX20ES.MIST	2.0	7.6	1.37	1.64	2.05	2.74	3450
2SX27ES.MIST	2.7	10.2	1.85	2.22	2.77	3.70	3450
2DX30ES.MIST	3.0	11.4	2.05	2.46	3.08	N/A	3450

DETERMINING THE PUMP R.P.M.	<u>Rated G.P.M.</u>	=	<u>"Desired" G.P.M.</u>
	<u>Rated R.P.M.</u>	=	<u>"Desired" R.P.M.</u>
DETERMINING THE REQUIRED H.P.	<u>GPM x PSI</u>	=	<u>Electric Brake</u>
	1460	=	<u>H. P. Required</u>
DETERMINING MOTOR PULLEY SIZE	<u>Motor Pulley O.D.</u>	=	<u>Pump Pulley O.D.</u>
	<u>Pump R.P.M.</u>	=	<u>Motor R.P.M.</u>

Refer to pump Service Manual for repair procedure, additional technical information and pump warranty.

"Customer confidence is our greatest asset"

EXPLODED VIEW

January 2009

PLUNGER PUMP MODELS

2DX05ELS.MIST, 2DX15ES.MIST,
2DX20ES.MIST, 2DX27ES.MIST
2DX30ES.MIST

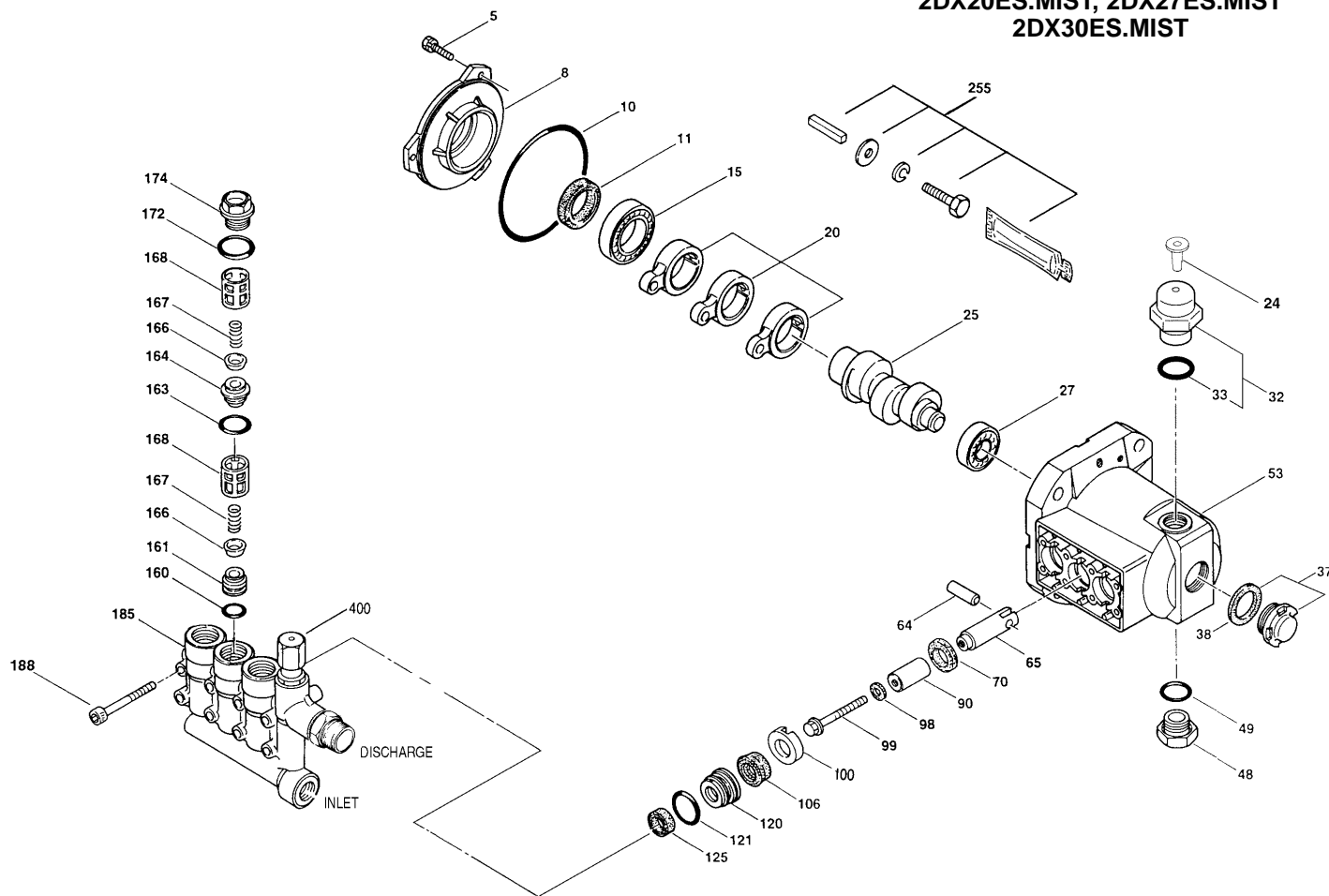

PARTS LIST

ITEM	P/N	MATL	DESCRIPTION	MODEL USED	QTY	ITEM	P/N	MATL	DESCRIPTION	MODEL USED	QTY
5	547161	STCP	Screw, HH (M6x14) [04/05]	All Models	3	98	46730	NBR	Washer, Seal - 90D	All Models	3
	549360	STCP R	Screw, HH (M6x14)	All Models	3	99	542405	S	Retainer, Plunger (M6x35)	All Models	3
8	547153	AL	Cover, Bearing [04/05]	All Models	1	100	46233	NY	Retainer, Seal	All Models	3
10	14041	NBR	O-Ring, Bearing Cover - 70D	All Models	1	106	48222	NBR	Seal, LPS w/S-Spg - 85D	All Models	3
11	55337	NBR	Seal, Oil - 70D	All Models	1	120	547357	BB	Case, Seal [02/03]	All Models	3
15	14488	STL	Bearing, Ball - Inner	All Models	1	121	13976	NBR	O-Ring, Seal Case - 70D	All Models	3
20	547048	TNM	Rod, Connecting	All Models	3	125	46240	NBR	Seal, HPS w/S	All Models	3
24	76045	LDPE	Plug, Oil Cap (remove before startup)	All Models	1	160	13965	NBR	O-Ring, Inlet Valve Seat - 70D	All Models	3
25	545653	CM	Crankshaft, 1725 RPM, 5/8", 2.0 mm	05ELS.MIST	1	161	545177	S	Seat, Inlet	All Models	3
	545144	CM	Crankshaft, 3450 RPM, 5/8", 3.0 mm	15ES.MIST	1	163	19285	NBR	O-Ring, Seat - 70D	All Models	3
	545765	CM	Crankshaft, 3450 RPM, 5/8", 4.0 mm	20ES.MIST	1	164	545178	S	Seat, Discharge	All Models	3
	545145	CM	Crankshaft, 3450 RPM, 5/8", 5.6 mm	27ES.MIST	1	166	46764	S	Valve	All Models	6
	549901	CM	Crankshaft, 3450 RPM, 5/8", 6.2 mm	30ES.MIST	1	167	46865	S	Spring	All Models	6
27	13832	STL	Bearing, Ball - Outer	All Models	1	168	543988	PVDF	Retainer, Spring	All Models	6
32	547961	RTP	Cap, Oil Filler w/O-Ring	All Models	1	172	142807	NBR	O-Ring, Plug - 90D	All Models	3
33	14179	NBR	O-Ring, Oil Filler Cap - 70D	All Models	1	174	46759	BB	Plug, Valve (M20x1.5)	All Models	3
37	92241	—	Gauge, Bubble Oil w/Gasket	All Models	1	185	548592	BB	Head, Manifold w/Integral Regulator Body	All Models	1
38	44428	NBR	Gasket, Flat Flex, Oil Gauge - 80D	All Models	1	188	542406	STZP	Screw, HSH (M6x60)	All Models	8
48	44842	NY	Plug, Drain	All Models	1		549357	STCP R	Screw, HSH (M6x60)	All Models	8
49	14179	NBR	O-Ring, Drain Plug - 70D	All Models	1	255	30516	STZP R	Assy, Bolt Mount	All Models	1
53	542407	AL	Crankcase [02/05]	All Models	1	300	33053	NBR	Kit, Seal (Incls: 98,106,121,125)	All Models	1
64	46229	CM	Pin, Crosshead	All Models	3	310	33057	NBR	Kit, Valve	All Models	1
65	542402	BBCP	Rod, Plunger	All Models	3				(Incls: 160,161,163,164,166,167,168,172)		
70	47215	NBR	Seal, Oil - 70D	All Models	3	400	—	—	Regulator, Integral (See Indiv. Parts)	All Models	1
90	542403	CC	Plunger (M16x27)	All Models	3						

Bold Part Numbers are unique to a particular pump model. Italics are optional items. [] Date of latest production change. R Components comply with RoHS Directive. See Tech Bulletins 002, 024, 036, 043, 055, 074, 083, and 094 for additional information.

MATERIAL CODES (Not Part of Part Number): AL=Aluminum BB=Brass BBCP=Brass/Chrome Plated CC=Ceramic CM=Chrome-moly LDPE=Low Density Polyethylene NBR=Medium Nitrile (Buna-N) NY=Nylon PVDF=Polyvinylidene Fluoride RTP=Reinforced Composite S=304SS STL=Steel STCP=Steel/Chrome Plated STZP=Steel/Zinc Plated TNM=Special High Strength

NOTE: Discard Key which may come standard with most motors and **use only the key included in this kit.**

INTEGRAL REGULATOR

SPECIFICATIONS

	U.S. Measure	Metric Measure
GPM.....	3.1 GPM	(11.7 L/M)
PSI Range.....	100-2000 PSI	(7-140 BAR)
Discharge Port	3/8" NPTM	(3/8" NPTM)

REGULATOR TYPE

An integral regulator with built-in by-pass is part of the discharge manifold to provide system pressure regulation and pump protection.

OPERATION:

Pump should be purged of air before commencing with operation. Liquid must flow through the pump without discharge restriction to assure full system pressure is reached.

Install a pressure gauge close to the manifold head of the pump to assist in setting system pressure and to periodically monitor system pressure.

Setting and adjusting the regulator pressure must be done with the system turned on. Start the system with the regulator backed off to the lowest pressure setting (counterclockwise direction). Read the pressure on the gauge at the pump. Do not read pressure at the nozzle. If more pressure is desired, turn adjusting cap one quarter turn in a clockwise direction and read the pressure. Repeat this process until the desired system pressure is reached.

NOTE: Pressure is not set at the factory.

SERVICE:

The regulator should be serviced on the same schedule as the seals in the pump. Refer to 2DX Service Manual for start-up, servicing of seals and valves, torque requirements and diagnosis and maintenance chart.

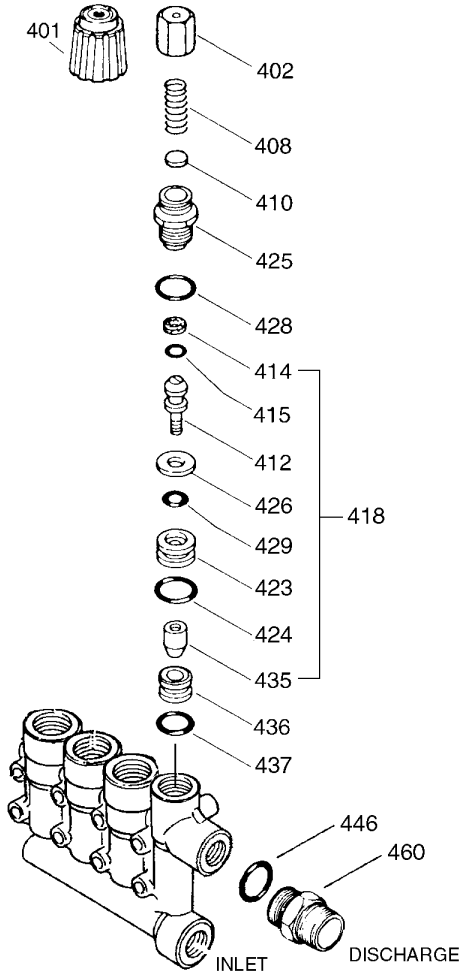

PARTS LIST

ITEM	PN	MATL	DESCRIPTION	QTY.
401	32088	NY	Handle, Adjusting	1
402	46570	BB	Cap, Adjusting	1
408	33394	STZP R	Spring, Pressure	1
410	549352	STCP R	Retainer, Spring	1
412	46251	BB	Stem, Piston	1
414	28338	PTFE	Back-up-Ring, Piston Stem	1
415	22056	NBR	O-Ring, Piston Stem - 70D	1
418	548229	BB	Assy, Piston <i>Incls: (412,414,415,423,424,426,429,435)</i>	1
423	46249	BB	Retainer, Valve	1
424	13966	NBR	O-Ring, Valve Retainer (Outer) - 70D	1
425	46248	BB	Retainer, Piston	1
426	46250	S	Washer	1
428	13969	NBR	O-Ring, Piston Retainer - 70D	1
429	17399	NBR	O-Ring, Valve Retainer (Inner) - 80D	1
435	548193	S	Valve	1
436	46253	S	Seat	1
437	13963	NBR	O-Ring, Seat - 70D	1
446	13969	NBR	O-Ring, Discharge Fitting - 70D	1
460	107681	BB	Fitting, Discharge (3/8" NPTM)	1
468	33099	NBR	Kit, O-Ring <i>(Incls: 414,415,424,428,429,437)</i>	1
—	31088	NBR	Kit, Repair <i>(Incls: 418,428,436,437)</i>	1

Italics are optional items. R Components comply with RoHS Directive.

MATERIAL CODES (Not Part of Part Number):

BB=Brass NBR=Medium Nitrile (Buna-N) NY=Nylon

PTFE=Pure Polytetrafluoroethylene S=304SS STCP=Steel/Chrome Plated
STZP=Steel/Zinc Plated

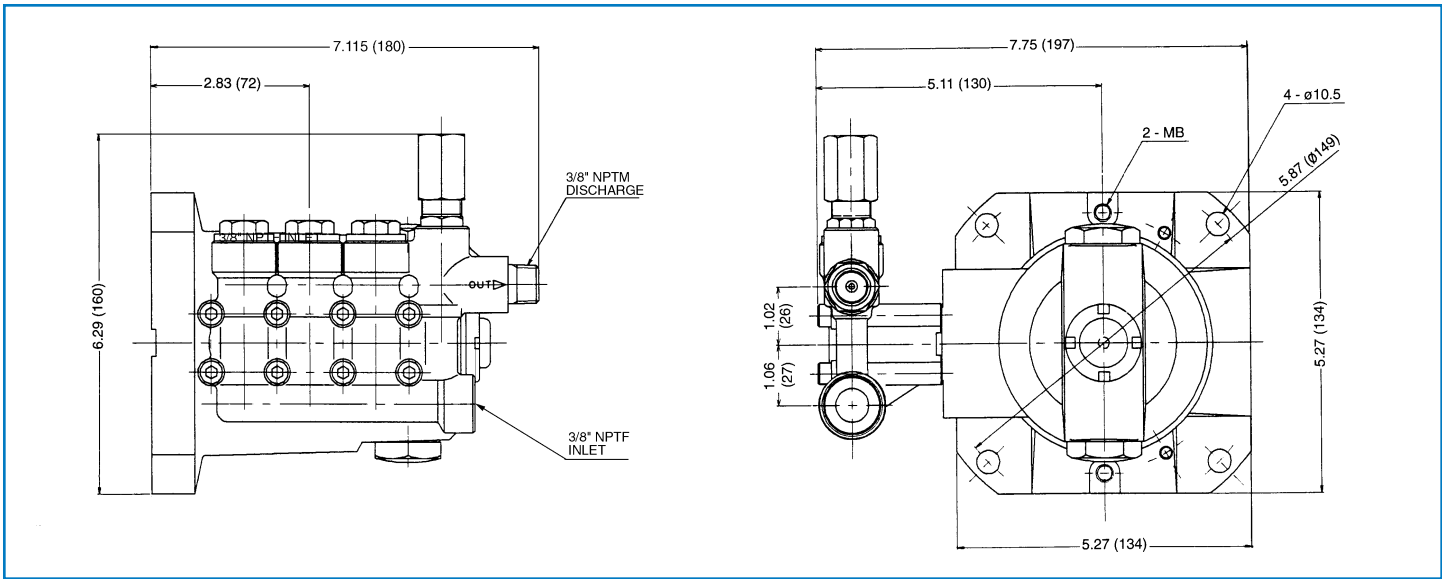

Models 2DX05ELS.MIST, 2DX15ES.MIST, 2DX20ES.MIST, 2DX27ES.MIST, 2DX30ES.MIST

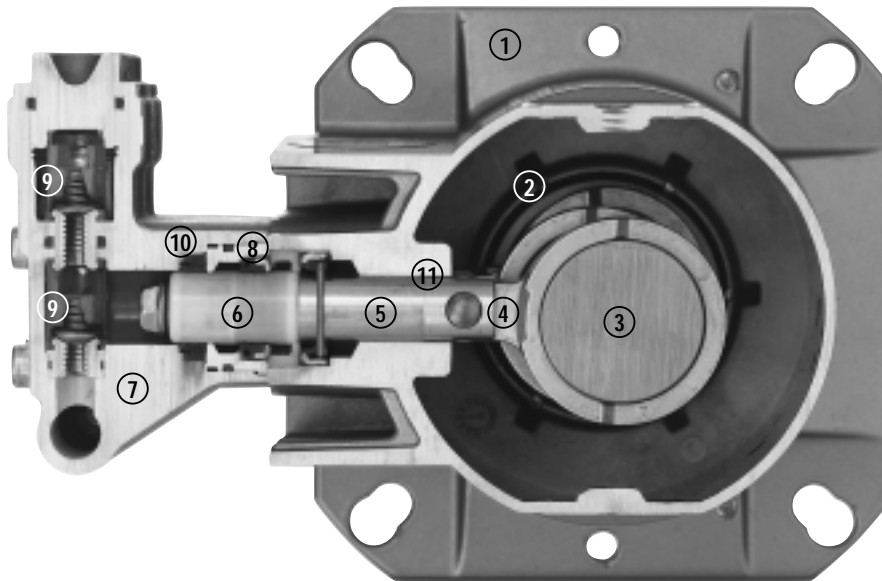

- | | | |
|--|---|--|
| <p>1 Die cast flange-style aluminum crankcase means high strength, lightweight, and excellent tolerance control.</p> <p>2 Heavy-duty dual crankshaft bearings provide extended drive-end life.</p> <p>3 Chrome-moly crankshaft provides unmatched strength and surface hardness for long life.</p> <p>4 High strength connecting rods assure durability and bearing quality.</p> | <p>5 Strong chrome plated brass plunger rods with chrom-moly crosshead pins.</p> <p>6 Special, concentric, high-density, polished solid ceramic plungers provide a true wear surface and extended seal life.</p> <p>7 High tensile strength, forged brass manifold head with built-in integral regulator and eight mounting screws for exceptional strength.</p> <p>8 100% wet seal design adds to service life by allowing pumped liquids to cool and lubricate on both sides.</p> | <p>9 Stainless steel valves, seats and springs provide corrosion-resistance, ultimate seating and extended life.</p> <p>10 Unique design and specially formulated Hi-Pressure Seals offer unmatched performance and seal life.</p> <p>11 Crossheads are 360° supported for uncompromising alignment.</p> |
|--|---|--|

Products described hereon are covered by one or more of the following U.S. patents 3558244, 3652188, 3809508, 3920356, 3930756 and 5035580

World Headquarters
CAT PUMPS
 1681 - 94th Lane N.E. Minneapolis, MN 55449-4324
 Phone (763) 780-5440 — FAX (763) 780-2958
 e-mail: techsupport@catpumps.com
 www.catpumps.com

International Inquiries
 FAX (763) 785-4329
 e-mail: intlsales@catpumps.com



CAT PUMPS (U.K.) LTD.
 1 Fleet Business Park, Sandy Lane, Church Crookham
 FLEET, Hampshire, GU52 8BF, England
 Phone Fleet 44 1252-622031 — Fax 44 1252-626655
 e-mail: sales@catpumps.co.uk www.catpumps.co.uk

N.V. CAT PUMPS INTERNATIONAL S.A.
 Heiveldekens 6A, B-2550 Kontich, Belgium
 Phone 32-3-450.71.50 — Fax 32-3-450.71.51
 e-mail: cpi@catpumps.be www.catpumps.be

CAT PUMPS DEUTSCHLAND GmbH
 Buchwiese 2, D-65510 Idstein, Germany
 Phone 49 6126-9303 0 — Fax 49 6126-9303 33
 e-mail: catpumps@t-online.de www.catpumps.de