

O.E.M. Triplex Plunger Pump

Direct-Drive Electric Models

2DX20E
2DX20EN

Direct-Drive Gas Models

2DX30GS
2DX30GNS

PUMP FEATURES

- Triplex plunger design provides a smooth fluid flow.
- Specially formulated Hi-Pressure Seals and ENP precisioned machined plungers assure maximum seal life.
- Ultimate compact, direct-drive unit for maximum portability.
- Modular Regulating Unloader with built-in by-pass standard on all units to assure system pressure control and pump protection.
- Built-in chemical injector standard on all units offers cleaning flexibility.
- Interchangeable, stacked valve design for ease in servicing.
- Inlet, swivel, garden hose fitting with filter screen.

Refer to pump Service Manual for important Inlet Condition Check-List, Start-up Procedure, Tech Bulletins and Pump Maintenance information.

SPECIFICATIONS

	U.S. Measure	Metric Measure
MODEL 2DX20E and 2DX20EN		
Volume	2.0 GPM	(7.6 L/M)
Max. Discharge Pressure	1500 PSI	(105 BAR)
RPM	3450 RPM	(3450 RPM)
Stroke	0.165"	(4.2 mm)
Shaft Diameter	5/8"	(15.8 mm)
MODEL 2DX30GS and 2DX30GNS		
Volume	3.0 GPM	(11.0 L/M)
Max. Discharge Pressure	2000 PSI	(140 BAR)
RPM	3400 RPM	(3400 RPM)
Stroke	0.244"	(6.2 mm)
Shaft Diameter	3/4"	(19.0 mm)
COMMON SPECIFICATIONS		
Inlet Pressure	Flooded to 60 PSI	(Flooded to 60 PSI)
Bore	0.630"	(16 mm)
Max. Fluid Temperature	140° F	(60° C)
Crankcase Capacity	8.5 oz.	(0.25 L)
Inlet Ports (1)	3/4" GH	(3/4" GH)
Discharge Port (1)	3/8" NPT	(3/8" NPT)
Chemical Injection Barb	8/32" UNF	(8/32" UNF)
Weight	11.7 lbs.	(5.3 kg)
Dimensions	7.99" x 7.75" x 6.29"	(203 x 197 x 160 mm)

EN, GNS = Nickel Plated Plungers, E, GS = Ceramic Plungers

“Customer confidence is our greatest asset”

EXPLODED VIEW

June 1998

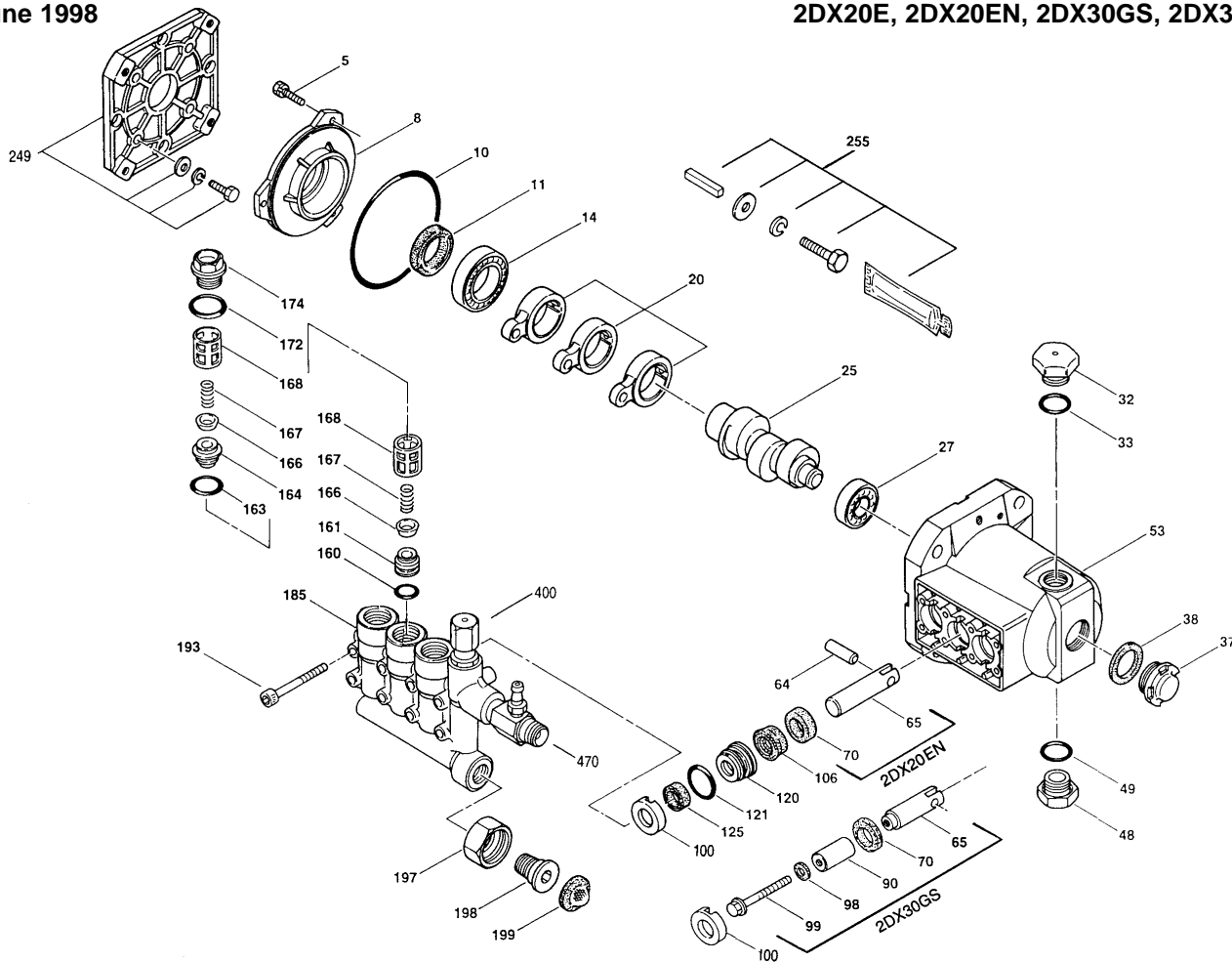

O.E.M. PLUNGER PUMP MODELS

2DX20E, 2DX20EN, 2DX30GS, 2DX30GNS

PARTS LIST

ITEM	PN	MATL	DESCRIPTION	QTY	ITEM	PN	MATL	DESCRIPTION	QTY
5	817003	STZP	Screw, HH w/SW (M6x12)	3	161	46760	BB	Seat, Inlet	3
8	46225	AL	Cover, Bearing	1	163	19285	NBR	O-Ring, Seat	6
10	14041	NBR	O-Ring, Bearing Cover - 70	1	164	46761	BB	Seat, Discharge	6
11	55337	NBR	Seal, Oil	1	166	46764	S	Valve	6
14	14488	STL	Bearing, Ball	1	167	46865	S	Spring	6
20	46228	HS	Rod, Connecting	3	168	543988	PVDF	Retainer, Spring	6
25	542981	CM	Crankshaft (4.2 mm) (3450)	1	172	11338	NBR	O-Ring, Plug	6
	543295	CM	Crankshaft (6.2 mm) (3400)	1	174	46759	BB	Plug, Valve (M22x1.5)	6
27	13832	STL	Bearing, Ball	1	185	542973	BB	Head, Manifold w/Modular Unloader Body	1
32	45690	RTP	Cap, Oil Filler	1	193	542406	STZP	Screw, HSH (M6x60)	8
33	14179	NBR	O-Ring, Oil Filler Cap - 70	1	197	46488	BB	Fitting, (3/8" NPT)	1
37	43987		Gauge, Bubble Oil	1	198	46487	BB	Nut, Swivel (3/4")	1
38	44428	NBR	Gasket, Flat Flex, Oil Gauge	1	199	46489	SS	Screen, Inlet	1
48	44842	NY	Plug, Drain (1/2" NPT)	1	249	30520		Kit, Adapter Mount, Standard, GAS	1
49	14179	NBR	O-Ring, Drain Plug	1	46789	AL		Flange	1
53	542407	AL	Crankcase	1	44843	STZP		Screw, HH (5/16"-24UNFx20)	4
64	46229	S	Pin, Rist	3	15845	STZP		Lockwasher (M8)	4
65	542402	BBCP	Rod, Plunger (2DX20E, 2DX30GS)	3	12489	STZP		Washer, Flat (M8)	4
	46628	BBNP	Rod, Plunger (2DX20EN, 2DX30GNS)	3	255	30516	STZP	Kit, Bolt Mount, ELECTRIC/GAS	1
70	47215	NBR	Seal, Oil	3	34100	STZP		Screw, HH (3/8"-16UNCx1-3/8")	4
90	542403	CC	Plunger (2DX30GS)	3	30980	STZP		Washer, Flat (3/8")	4
98	46730	NBR	Washer, Seal	3	30921	STZP		Lockwasher (3/8")	4
99	542405	S	Retainer, Plunger (M6x35)	3	6106			Lubricant, Anti-Seize	1
100	46233	NY	Retainer, Seal	3	34050	STL		Key (3/16x3/16x27 HD)	1
106	48222	NBR	Seal, LPS w/S-Spg	3	300	33053	NBR	Kit, Seal (Incls: 98,106,121,125)	1
120	46436	BB	Case, Seal	3	310	33057	BBS	Kit, Valve (Incls: 160,161,163,164,166,167,168,172)	2
121	13976	NBR	O-Ring, Seal Case	3	400	—		Unloader, Modular - See Individual Parts	1
125	46240	NBR	Seal, HPS w/S	3	470	—		Injector, Chemical - See Individual Parts	1
160	13965	NBR	O-Ring, Inlet Valve Seat	3					

Italics are optional items. See Tech Bulletins 24, 43 and 74 for additional information.

MATERIAL CODES (Not Part of Part Number): AL=Aluminum BB=Brass BBCP=Brass/Chrome Plated BBNP=Brass/Nickel Plated BBS=Brass/304SS

CC=Ceramic CM=Chrome-moly HS=High Strength NBR=Medium Nitrile (Buna-N) NY=Nylon PVDF=Fluoroplastic (High Strength)

RTP=Reinforced Composite S=304SS SS=316SS STL=Steel STZP=Steel/Zinc Plated

NOTE: Discard Key which may come standard with most motors and engines and **use only the key included in this kit.**

Center raised pilot guide on the **Adapter Plate** assures proper alignment of pump and engine. Before mounting pump onto engine inspect engine for **recessed seal and bearing guide** to permit adapter to completely seat into recess and four bosses to be flush with engine face.

MODULAR UNLOADER

SPECIFICATIONS	U.S. Measure	Metric Measure
GPM	3.0 GPM	(11.0 L/M)
PSI	100-1500 PSI	(1-105 BAR)
Discharge Port	3/8" NPT	(3/8" NPT)

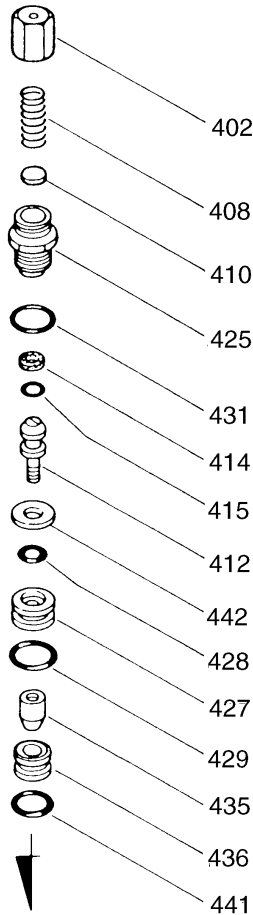

ITEM	PN	MATL	DESCRIPTION	QTY.
402	46570	BB	Cap, Adjusting	1
408	33394	STZP	Spring, Coil, 2000 PSI (2DX30G, GNS)	1
410	45862	BB	Retainer, Spring	1
412	46251	BB	Stem, Piston	1
414	28338	PTFE	Back-up-Ring, Piston Stem	1
415	22056	NBR	O-Ring, Piston Stem	1
425	46248	BB	Retainer, Piston	1
427	46249	BB	Retainer, Valve	1
428	17399	NBR	O-Ring, Valve Retainer (Inner)	1
429	13966	NBR	O-Ring, Valve Retainer (Outer)	1
431	13969	NBR	O-Ring, Piston Retainer - 70	1
435	46733	S	Valve	1
436	46253	S	Seat	1
441	13963	NBR	O-Ring, Seat	1
442	46250	SS	Washer	1
468	33099		<i>Kit, O-Ring</i>	1

(Includes: 414, 415, 416, 428, 429, 431, 441)

Italics are optional items.

MATERIAL CODES (Not Part of Part Number): BB=Brass
NBR=Medium Nitrile (Buna-N) PTFE=Polytetrafluoroethylene (Teflon®)
S=304SS SS=316SS STZP=Steel/Zinc Plated

The modular Regulating Unloader with built-in by-pass is part of the discharge manifold and is very easily serviced from the top. Remove Hex Adjusting Cap and lift parts from body.

If unit is INFREQUENTLY USED OR PERIODICALLY STORED, seals may become dry. System should be PURGED OF AIR BEFORE OPERATION (system fluid must flow through the pump without discharge restriction) to assure full system pressure is reached.

FIXED CHEMICAL INJECTOR

SPECIFICATIONS	U.S. Measure	Metric Measure
Model 7231		
GPM	2.0 GPM	(7.6 L/M)
Nozzle Orifice	1.8 mm	(1.8 mm)

Model 7232		
GPM	3.0 GPM	(11.0 L/M)
Nozzle Orifice	2.1 mm	(2.1 mm)

Common Specifications

Hose Barb	1/4"	(1/4")
Tapped Barb	8/32" UNF	(8/32" UNF)
Inlet Port	M18x1.0	(M18x1.0)
Discharge Port	3/8" NPTM	(3/8" NPTM)
Weight	5.3 oz.	(0.15 kg)
Dimensions	2" x 1" x 1.75"	(52 x 25 x 45 mm)

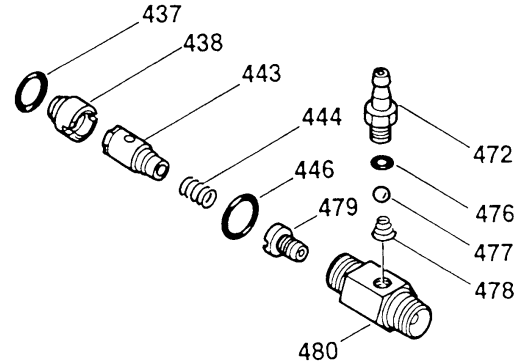

ITEM	PN	MATL	DESCRIPTION	QTY.
437	13963	NBR	O-Ring, Seat	1
438	46254	NY	Seat	1
443	541060	BB	Valve, Check w/O-Ring	1
444	45924	S	Spring	1
446	13969	NBR	O-Ring, Adapter	1
472	46630	BB	Barb, Tapped	1
476	14187	NBR	O-Ring, Injector Valve	1
477	46259	S	Ball	1
478	46260	S	Spring, Injector Valve	1
479	46531	BB	Orifice (2.1 mm)	1
	46257	BB	Orifice (1.8 mm)	1
480	—	BB	Body	1

MATERIAL CODES (Not Part of Part Number):
BB=Brass NBR=Medium Nitrile (Buna-N) NY=Nylon S=304SS

CHEMICAL INJECTOR PERFORMANCE CHART

Optional Special Ported Chemical Injector for Unloader Mounting

Standard Pump Model	Injector Orifice Size	Injector Model	Lo-Pressure Nozzle Rating (Max. Downstream) (Press for Injector)	Max. Chem. Draw (0 PSI) (Downstream)	Hi-Press Nozzle "Deduction" (Press drop across Inj.)
2DX20E, EN	1.8 mm	7231	100 PSI	52 oz/min	100 PSI
2DX30GS, GNS	2.1 mm	7232	150 PSI	50 oz/min	125 PSI

Optimum performance of chemical injector occurs with a 35 ft. high pressure hose and a minimum 3/8" I.D. The type of hose, extended lengths, reduced I.D. and fittings may create back pressures in excess of the low pressure nozzle rating and prevent the injector from drawing chemical. See Hose Friction Loss Chart in High Pressure Guide. **Deduct hose friction loss from above low PSI Nozzle. Consult factory for assistance with other options.**

CAUTION:

Deduct the pressure drop shown in the performance chart from your desired system pressure to arrive at the maximum high pressure nozzle rating. This is essential to avoid over-pressurizing the pump.

The Chemical Injector is mounted directly to the discharge of the unloader. **Chemical draw occurs under low pressure.** Select the *Dual Nozzle* (32149), *Adjustable Nozzle* (32151), or *Vari-Nozzle* (7930-7980) to permit the adjustment from low to high pressure

For correct nozzle selection, **read system pressure at the pump. DO NOT READ SYSTEM PRESSURE AT THE HIGH PRESSURE GUN.** Incorrect pressure reading may result in: pump operation at excessive pressures, inconsistent chemical draw or possible damage to the pump or unloader.

DIMENSIONAL DRAWING

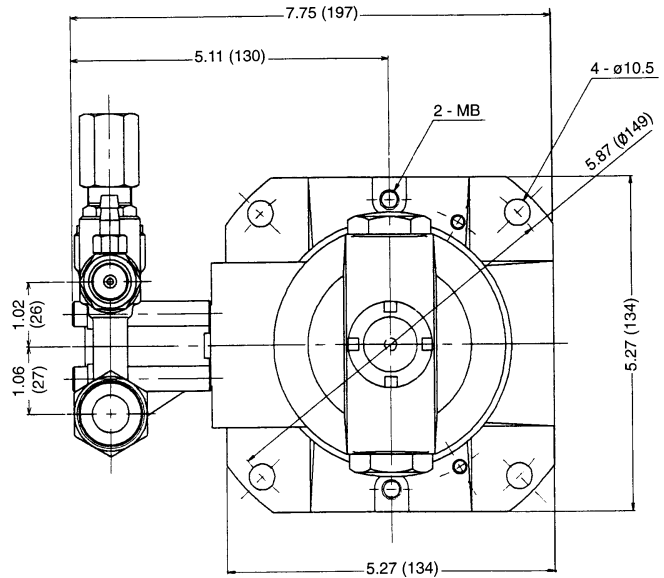
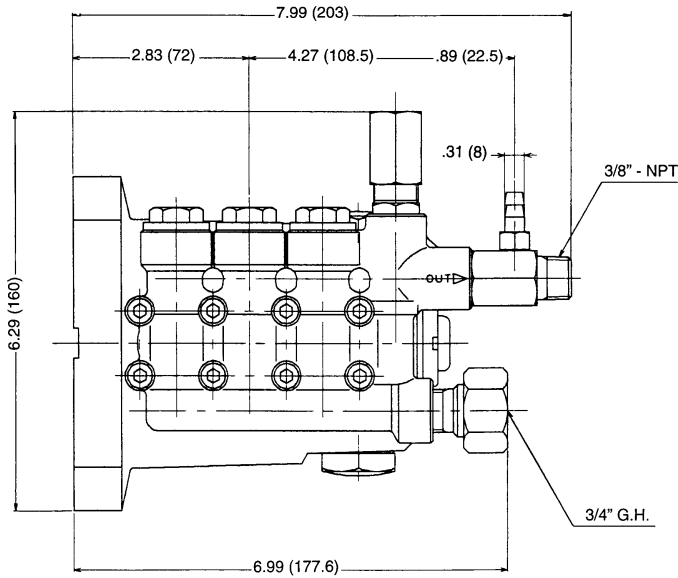

DETERMINING THE REQUIRED H.P.

$$\text{GPM} \times \text{PSI} = \text{Electric Brake H.P. Required}$$

1460

HORSEPOWER REQUIREMENTS

Flow		Pressure				Pump RPM
		PSI 1000	PSI 1200	PSI 1500	PSI 2000	
GPM	L/M	BAR 70	BAR 85	BAR 105	BAR 140	
2.0	7.6	1.4	1.6	2.1	2.7	3450
3.0	11.0	2.1	2.5	3.1	4.2	3400

Products described hereon are covered by one or more of the following U.S. patents 3558244, 3652188, 3809508, 3920356, 3930756 and 5035580

June 1998 6882

World Headquarters

CAT PUMPS

1681 - 94th Lane N.E. Minneapolis, MN 55449-4324

Phone (612) 780-5440 — FAX (612) 780-2958

e-mail: sales@catpumps.com

www.catpumps.com

International Inquiries

FAX (612) 785-4443

e-mail: intlsales@catpumps.com



The Pump with "Nine Lives"

CAT PUMPS (U.K.) LTD.

1 Fleet Business Park, Sandy Lane, Church Crookham, Fleet

Hampshire GU13 0BF, England

Phone Fleet 44 1252-622031 — Fax 44 1252-626655

N.V. CAT PUMPS INTERNATIONAL S.A.

Heiveldkens 6A, 2550 Kontich, Belgium

Phone 32-3-450.71.50 — Fax 32-3-450.71.51

e-mail: cpi@catpumps.be

CAT PUMPS DEUTSCHLAND GmbH

Buchwiese 2, D-65510 Idstein, Germany

Phone 49 6126-93030 — Fax 49 6126-930333

e-mail: catpumps@t-online.de