



FEATURES

- Square, ventilated, durable black nylon Insulator for operator comfort and safety.
- Suitable for hot or cold water cleaning.
- Durable 2-piece Nozzle Protector reduces nozzle clogging and damage.
- Zinc plated and 304SS construction for cleaning flexibility.



FEATURES

- Lightweight molded lance for sure grip and optimum control.
- New molded insulator eliminates assembly and adjustment.
- Optional lengths for flexibility and specialized cleaning.

Single Lances

Zinc Plated Models 31017
32031, 32032, 32033
32034, 32035, 32036

SPECIFICATIONS

	U.S. Measure	Metric Measure
Maximum Flow	10.5 GPM	(40 L/M)
Maximum Pressure	3650 PSI	(250 BAR)
Maximum Temperature	320°F	(160°C)
Inlet Fitting (32036 Only)	1/4" NPTM	(1/4" NPTM)
Inlet Fitting	1/4" BSPM	(1/4" BSPM)
Nozzle Holder	1/4" NPTF	(1/4" NPTF)
	32036	
	31017	32031 32032
Length (in/mm)	27"/700	36"/900 48"/1200
Weight (oz./kg)	21.8/.62	24.2/.69 35.4/1.01
	32033 32034 32035	
Length (in/mm)	60"/1500	67"/1700 79"/2000
Weight (oz./kg)	41/1.17	43.8/1.25 49.1/1.40

Stainless Model 32042

SPECIFICATIONS

	U.S. Measure	Metric Measure
Maximum Flow	10.5 GPM	(40 L/M)
Maximum Pressure	3650 PSI	(250 BAR)
Maximum Temperature	320°F	(160°C)
Inlet Fitting	1/4" NPTM	(1/4" NPTM)
Nozzle Holder	1/4" NPTF	(1/4" NPTF)
Length	36"	(900 mm)
Weight	21.8 oz.	(.60 kg)

Square Molded Zinc Plated Models 32264
32268, 36267, 36269

SPECIFICATIONS

	U.S. Measure	Metric Measure
Maximum Flow	10.5 GPM	(40 L/M)
Maximum Pressure	3650 PSI	(250 BAR)
Maximum Temperature	320°F	(160°C)
Inlet Fitting	1/4" BSPM	(1/4" BSPM)
Discharge Fitting	1/4" BSPM	(1/4" BSPM)
	32264	
Length (in/mm)		24"/600
Weight (oz./kg)		14.9/.42
	36267 32268 36269	
Length (in/mm)	36"/900	48"/1200 60"/1500
Weight (oz./kg)	21.0/.60	29.8/.84 36.0/1.02

"Customer confidence is our greatest asset"

EXPLODED VIEW (Models 31017, 32031-32042)

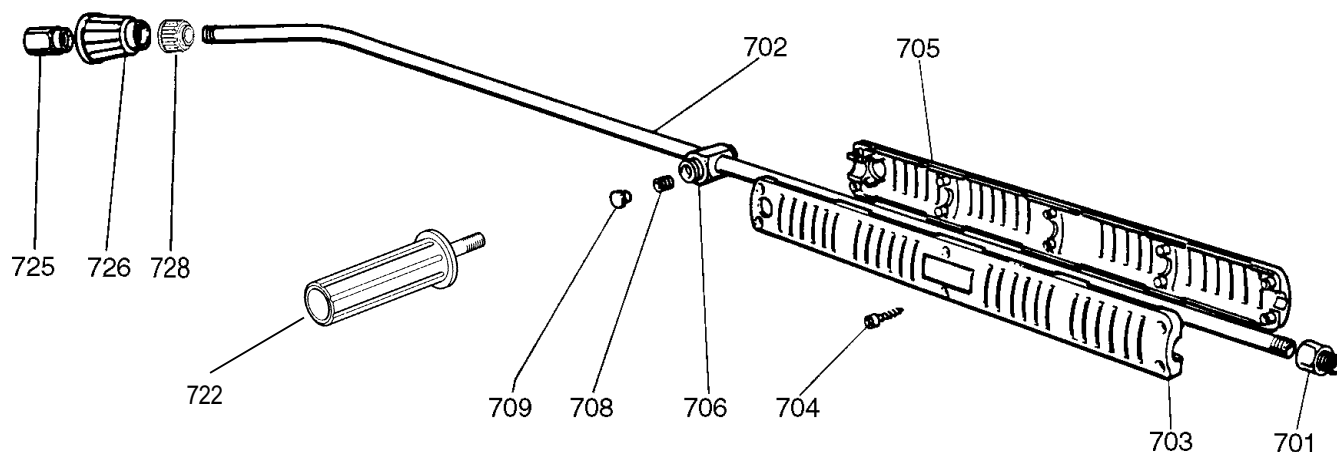

PARTS LIST

ITEM	P/N	MATL	DESCRIPTION	QTY.	ITEM	P/N	MATL	DESCRIPTION	QTY.
701	32868	BB	Fitting, Inlet (1/4")	1	709	32871	NY	Plug	1
702	—	ZP	Tube (600-2000 mm)	1	722	32698	NY	Assy, Side Grip	1
		S	Tube (700-2000 mm)	1	725	32053	STZP	Holder, Nozzle (14"NPTF x 1/4"NPTF)	1
703	—	NY	Cover, Lance, Left	1	726	31060	—	Protector, Nozzle	1
704	—	STZP	Screw, Self-Threading (M3.5x18)	6	728	31110	NY	Collar, Protector	1
705	—	NY	Cover, Lance, Right	1	735	31169	NY	Assy, Protector (Inclds: 726, 728)	1
706	—	NY	Adapter, Side Grip	1	736	32865	—	Assy, Insulator (Inclds: 703, 704, 705, 706)	1
708	32870	STZP	Screw, Set (M10)	1					

Italics are optional items.

Material Codes (Not Part of Part No.: BB=Brass NY=Nylon S=304SS STZP=Steel/Zinc Plated ZP=Zinc Plated)

SELECTION: Select a lance that matches the system flow and pressure to assure safety during operation. Select standard zinc plated or 304SS for compatibility and longer life.

INSTALLATION: Install these single lances onto any 1/4" fitted gun. Use PTFE thread tape or pipe thread sealant to assure an air tight fit and thread on hand tight until no leaking is visible.

NOTE: To install optional grip assembly, remove black nylon plug and M10 set screw. Thread the side grip assembly in by hand until it is snug.

OPERATION: Flow goes through the lance as soon as the trigger on the gun is squeezed.

⚠ WARNING

**Severe injury can occur with high pressure spray.
Do not allow spray to contact any part of body.**

TROUBLESHOOTING

Leaking at gun connection	• Check fitting for proper sealant and reconnect to gun.
Leaking at nozzle	• Check for proper sealant at lance and nozzle protector connection and reconnect.
Broken nozzle protector	• Replace to assure nozzle life.

WARRANTY

90 Day Warranty

Refer to complete CAT PUMPS Warranty for further information.

Products described hereon are covered by one or more of the following U.S. patents 3558244, 3652188, 3809508, 3920356, 3930756 and 5035580

World Headquarters

CAT PUMPS

1681 - 94th Lane N.E. Minneapolis, MN 55449-4324

Phone (763) 780-5440 — FAX (763) 780-2958

e-mail: techsupport@catpumps.com

www.catpumps.com

International Inquiries

FAX (763) 785-4329

e-mail: intlsales@catpumps.com



The Pumps with Nine Lives

CAT PUMPS (U.K.) LTD.

1 Fleet Business Park, Sandy Lane, Church Crookham

FLEET, Hampshire, GU52 8BF, England

Phone Fleet 44 1252-622031 — Fax 44 1252-626655

e-mail: sales@catpumps.co.uk

N.V. CAT PUMPS INTERNATIONAL S.A.

Heiveldkens 6A, B-2550 Kontich, Belgium

Phone 32-3-450.71.50 — Fax 32-3-450.71.51

e-mail: cpi@catpumps.be www.catpumps.be

CAT PUMPS DEUTSCHLAND GmbH

Buchwiese 2, D-65510 Idstein, Germany

Phone 49 6126-9303 0 — Fax 49 6126-9303 33

e-mail: catpumps@t-online.de www.catpumps.de