



FEATURES

- Eliminates belt selection, sizing and adjustment.
- Compact direct mounting feature reduces space required for belts or gearbox drive assemblies.
- Insulates against heat transfer.
- No moving parts for long life and easy maintenance.
- For a complete drive package, combine with CAT PUMPS' Flexible Coupling designed for extended life in high temp and high RPM conditions.

DIRECT-DRIVE SELECTION CHART			
Pump Selection	Motor Frame Options	Flexible Coupling Assembly	Bell Housing Assembly
3PFR Pumps 230, 231, 237 240, 241, 247 270, 271, 277	56C	8215	34121
	143-145TC	8210	34121
	182-184TC 3HP	8220	34126
	182-184TC 5HP	8225	34126
	213-215TC	8270	34126 and 990213*
5PFR Pumps 340, 341, 347 350, 351, 357	143-145TC	8260	N/A
	182-184TC	8230	34131
	213-215TC	8275	34131 and 990213*
3CP Pumps 3CP1120, 3CP1221 3CP1130, 3CP1231 3CP1240, 3CP1241	56C	8215	34422
	143-145TC	8210	34422
	182-184TC 3HP	8220	34423
	182-184TC 5HP	8225	34423
	213-215TC	8270	34423 and 990213*
5CP Pumps 5CP2140WCS, 5CP2150W 5CP6241CS, 5CP6251	143-145TC	8260	35421
	182-184TC	8230	34424
	213-215TC	8275	34424 and 990213*
7CP Pumps 7CP6110	184TC	8370	31570
	213-215TC	8375	31570
	254-256TC	8380	31570 and 990213**

*Adapter Kit PN 990213 must be used with Bell Housing to convert motor frame to 213-215TC.

**Adapter Kit PN 990213 must be used with Bell Housing to convert motor frame to 254-256TC.

Direct-Drive Bell Housings

Use with 3PFR and 5PFR Plunger Pumps

Models 34121, 34126
34131

Use with 3CP and 5CP Plunger Pumps

Models 34422, 34423
34424, 35421

Use with 7CP Plunger Pumps

Model 31570

SPECIFICATIONS

	34121	34126
Motor Frame	56C, 145TC	182TC, 184TC
Weight.....	1.18 lbs. (0.51 kg)	1.88 lbs. (0.85 kg)
Dimensions	Motor Face..... 6.64" (169 mm)	8.75" (222 mm)
	Pump Face	4.90" (124 mm)
	Length.....	4.86" (123 mm)

	34131
Motor Frame	182TC, 184TC
Weight.....	1.88 lbs. (0.85 kg)
Dimensions	Motor Face.....
	Pump Face.....
	Length.....

	34422	34423
Motor Frame	56C, 145TC	182TC, 184TC
Weight.....	2.44 lbs. (1.10 kg)	3.44 lbs. (1.56 kg)
Dimensions	Motor Face.....	8.75" (222 mm)
	Pump Face	4.90" (124 mm)
	Length.....	5.11" (130 mm)

	34424	35421
Motor Frame	184TC	56C, 145TC
Weight.....	3.49 lbs. (1.58 kg)	2.48 lbs. (1.12 kg)
Dimensions	Motor Face.....	8.75" (222 mm)
	Pump Face	4.90" (124 mm)
	Length.....	5.11" (130 mm)

	31570
Motor Frame	184TC, 213-215TC
Weight.....	3.06 lbs. (1.36 kg)
Dimensions	Motor Face.....
	Pump Face.....
	Length.....

"Customer confidence is our greatest asset"

PARTS LIST

31570 Bell Housing Assembly 184TC, 213-215TC

1	—	Bell Housing
4	992772	Screw, HH (1/2"-13x1-1/4")
4	992782	Lockwasher (1/2")
8	992877	Screw, FH (M8x25)
8	992879	Lockwasher (M8)

34121 Bell Housing Assembly 56C, 145TC

1	—	Bell Housing
4	992771	Screw, HH (3/8"-16x3/4")
4	992781	Lockwasher (3/8")
4	34379	Screw, FH (M6x20) HD
4	126745 R	Lockwasher (M6)

34126 Bell Housing Assembly 182TC, 184TC

1	—	Bell Housing
4	992870	Screw, HHC (1/2"-13x1")
4	992782	Lockwasher (1/2")
4	34379	Screw, FH (M6x20) HD
4	126745 R	Lockwasher (M6)

34131 Bell Housing Assembly 182TC, 184TC

1	—	Bell Housing
4	992870	Screw, HHC (1/2"-13x1")
4	992782	Lockwasher (1/2")
4	34379	Screw, FH (M6x20) HD
4	126745 R	Lockwasher (M6)

R Components comply with RoHS Directive.

34422 Bell Housing Assembly 56C, 145TC

1	—	Bell Housing
4	992771	Screw, HH (3/8"-16x3/4")
4	992781	Lockwasher (3/8")
4	992874	Screw, FH (M6x20) HD
4	992875	Lockwasher (M6)

34423 Bell Housing Assembly 182TC, 184TC

1	—	Bell Housing
4	992772	Screw, HH (1/2"-13x1-1/4")
4	992782	Lockwasher (1/2")
4	992874	Screw, FH (M6x20) HD
4	992875	Lockwasher (M6)

34424 Bell Housing Assembly 184TC

1	—	Bell Housing
4	992772	Screw, HH (1/2"-13x1-1/4")
4	992782	Lockwasher (1/2")
4	992877	Screw, FH (M8x25)
4	992879	Lockwasher (M8)

35421 Bell Housing Assembly 56C, 145TC

1	—	Bell Housing
4	992771	Screw, HH (3/8"-16x3/4")
4	992781	Lockwasher (3/8")
4	992877	Screw, FH (M8x25)
4	992879	Lockwasher (M8)

INSTALLATION

- Separate the parts which are included in the bell housing assembly package. The bell housing assembly is offered in separate kits to cover the various horsepower and pump models. Note: See separate data sheet for available flexible coupling assemblies.
- Remove bearing case screws from extended shaft side of pump and **discard**.
- Slip the bell housing over the pump shaft with the **cover to the top** and drain hole to the bottom.
- Apply Loctite® 242® to the threads of the screws provided in the assembly and torque to **50 in/lbs. (5.5 Nm)** in alternating rotation.
- Apply a light film of antiseize lubricant to pump shaft.
- Separate M16.5, M20 or M24 half of the flexible coupling and slide onto the pump shaft. Seat completely against the step on crankshaft.
- Install key into pump shaft with curved end up and towards pump.
- * Insert 3mm allen wrench into each set screw and torque to **125-150 in/lbs. (15-19 Nm)**.
- Slide 5/8, 7/8, 1-1/8, 1-3/8" or 1-5/8" half of flexible coupling **containing spyder** onto motor shaft.
- Install motor key (supplied with motor) into motor shaft keyway and apply antiseize lubricant to shaft.
- Mount pump with coupling half onto motor shaft with coupling half, lining up the two halves. Apply Loctite® 242® to threaded area of the bolts, slip lockwashers onto bolts and thread through flange into motor. Torque to **110 in/lbs. (12 Nm)** in alternating rotation.
- To secure flexible coupling with set screw, remove cover, insert screwdriver into the bell housing and **press flexible coupling towards pump**. NOTE: Flexible coupler halves should not contact each other. Ensure there is a small gap between coupler halves.
- Rotate motor shaft so set screws are lined-up with bell housing opening. NOTE: One set screw located at keyway and second at 90° from keyway.
- * Insert 3mm allen wrench into each set screw and torque to **125-150 in/lbs. (15-19 Nm)**. Replace cover.

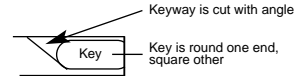

*Note: Flexible Couplings that fit the 7CP plunger pumps do not have set screws, but a cross clamp socket head screw (6 mm Allen). Torque to 25 ft/lbs (35 Nm).
Loctite and 242 are registered trademarks of the Henkel Corporation.

DIMENSIONAL

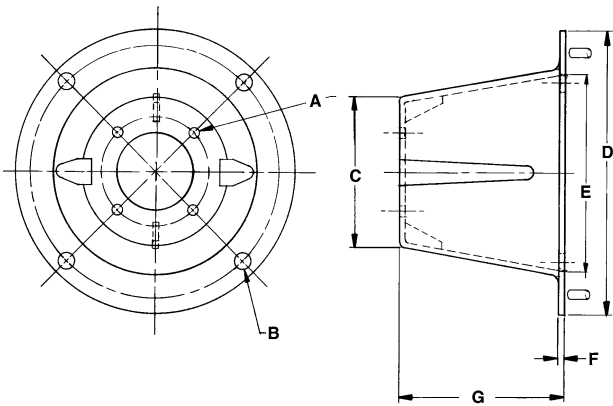

MODEL	A	B	C	D	E	F	G
31570	.354 (3.858 BC)	.565 (7.250 BC)	5.13 (130)	8.75 (222)	5.63 (143)	.43 (11)	6.02 (153)
34121	.252 (2.520 BC)	.438 (5.875 BC)	4.9 (124)	6.64 (169)	4.4 (112)	.31 (8)	4.14 (105)
34126	.252 (2.520 BC)	.565 (7.250 BC)	4.9 (124)	8.75 (228)	5.47 (139)	.43 (11)	4.86 (123)
34131	.252 (2.953 BC)	.565 (7.250 BC)	4.9 (124)	8.75 (228)	5.47 (139)	.43 (11)	4.86 (123)
34422	.252 (2.992 BC)	.438 (5.875 BC)	4.9 (124)	6.64 (169)	4.4 (112)	.31 (8)	4.14 (105)
34423	.252 (2.992 BC)	.565 (7.250 BC)	4.9 (124)	8.75 (222)	5.47 (139)	.43 (11)	5.11 (130)
34424	.335 (3.071 BC)	.565 (7.250 BC)	4.9 (124)	8.75 (222)	5.47 (139)	.43 (11)	5.11 (130)
35421	.335 (3.071 BC)	.438 (5.875 BC)	4.9 (124)	6.64 (169)	4.4 (112)	.31 (8)	4.14 (105)

WARRANTY

90 Day Warranty

Refer to complete CAT PUMPS Warranty for further information.

Products described hereon are covered by one or more of the following U.S. patents 3558244, 3652188, 3809508, 3920356, 3930756 and 5035580

World Headquarters

CAT PUMPS

1681 - 94th Lane N.E. Minneapolis, MN 55449-4324

Phone (763) 780-5440 — FAX (763) 780-2958

e-mail: techsupport@catpumps.com

www.catpumps.com

International Inquiries

FAX (763) 785-4329

e-mail: intlsales@catpumps.com



The Pumps with Nine Lives

CAT PUMPS (U.K.) LTD.

1 Fleet Business Park, Sandy Lane, Church Crookham

FLEET, Hampshire, GU52 8BF, England

Phone Fleet 44 1252-622031 — Fax 44 1252-626655

e-mail: sales@catpumps.co.uk

N.V. CAT PUMPS INTERNATIONAL S.A.

Heiveldekens 6A, B-2550 Kontich, Belgium

Phone 32-3-450.71.50 — Fax 32-3-450.71.51

e-mail: cpi@catpumps.be www.catpumps.be

CAT PUMPS DEUTSCHLAND GmbH

Buchwiese 2, D-65510 Idstein, Germany

Phone 49 6126-9303 0 — Fax 49 6126-9303 33

e-mail: catpumps@t-online.de www.catpumps.de