

Electric Motor or Gas Engine must be purchased separately.

Triplex Plunger Pump

4SF

SPECIFICATIONS

	U.S. Measure	Metric Measure	U.S. Measure	Metric Measure
Model			4SF35GH1	
Volume			3.5 GPM	(13.2 L/M)
Max. Discharge Pressure			3000 PSI	(210 BAR)
Max. RPM			3200 RPM	(3200 RPM)
Stroke			0.197"	(5.0 mm)

Model	4SF40ELH		4SF40GH1	
Volume	4.0 GPM	(15.1 L/M)	4.0 GPM	(15.0 L/M)
Max. Discharge Pressure	3000 PSI	(210 BAR)	3000 PSI	(210 BAR)
Max. RPM	1725 RPM	(1725 RPM)	3200 RPM	(3200 RPM)
Stroke	0.382"	(9.7 mm)	0.224"	(5.7 mm)

Model	4SF45ELH	
Volume	4.5 GPM	(17 L/M)
Max. Discharge Pressure	3000 PSI	(210 BAR)
Max. RPM	1725 RPM	(1725 RPM)
Stroke	0.437"	(11.1 mm)

Model	4SF45GH1		4SF45GH118	
Volume	4.5 GPM	(17 L/M)	4.5 GPM	(17 L/M)
Max. Discharge Pressure	3000 PSI	(210 BAR)	3000 PSI	(210 BAR)
Max. RPM	3200 RPM	(3200 RPM)	3200 RPM	(3200 RPM)
Stroke	0.256"	(6.5 mm)	0.256"	(6.5 mm)

Model	4SF50ELH		4SF50GH1	
Volume	5.0 GPM	(19.0 L/M)	5.0 GPM	(19.0 L/M)
Max. Discharge Pressure	3000 PSI	(210 BAR)	3000 PSI	(210 BAR)
Max. RPM	1725 RPM	(1725 RPM)	3200 RPM	(3200 RPM)
Stroke	0.455"	(11.5 mm)	0.276"	(7.0 mm)

ELH = Electric 1-1/8" hollow shaft with bolt mount
 GH1 = Gas 1" hollow shaft with bolt and adapter mount
 GH118 = Gas 1-1/8" hollow shaft with bolt and adapter mount

- For **MAXIMUM SUCTION** capability, Regulating Unloader should be remounted on discharge manifold, OPPOSITE from inlet port. Contact factory for proper setup of Inlet Suction Kit.

PUMP FEATURES

- UNIFLOW design provides continuous fluid flow forward through the pump, reduces cavitation risk and increases pump life.
- Unique spring loaded inlet valves and the flow through ceramic plungers allow excellent suction capabilities.
- Compact, hollow shafted pump for direct mounting to either gas or electric motor, eliminates the need for pulleys, belts, gearboxes.
- Regulating Unloader mounts directly on each pump to assure system pressure control and pump protection.
- Convenient multiple porting provides installation flexibility.

COMMON PUMP SPECIFICATIONS

Max. Inlet Pressure (Electric)	-2 to 75 PSI	(-0.14 to 5.25 BAR)
Max. Inlet Pressure (Gas)	Flooded to 75 PSI	(Flooded to 5.25 BAR)
Bore	0.787"	(20 mm)
Max Fluid Temperature	160° F	(71° C)
Crankcase Capacity	20 oz.	(.72 L)
Inlet Port (1)	1/2" NPT	(1/2" NPT)
By-Pass Port (1)	3/8" NPT	(3/8" NPT)
Discharge Ports (2)	3/8" NPT	(3/8" NPT)
Auxiliary Port (1)	1/4" NPT	(1/4" NPT)
Weight Pump	24.31 lbs.	(11.0)
Dimensions (Pump Only)	8.27" x 11.06" x 12.28"	(210 x 281 x 312 mm)

Refer to pump Service Manual for important Inlet Condition Check-List, Start-up Procedure, Tech Bulletins and Pump Maintenance information.

"Customer confidence is our greatest asset"

EXPLODED VIEW

August 1994

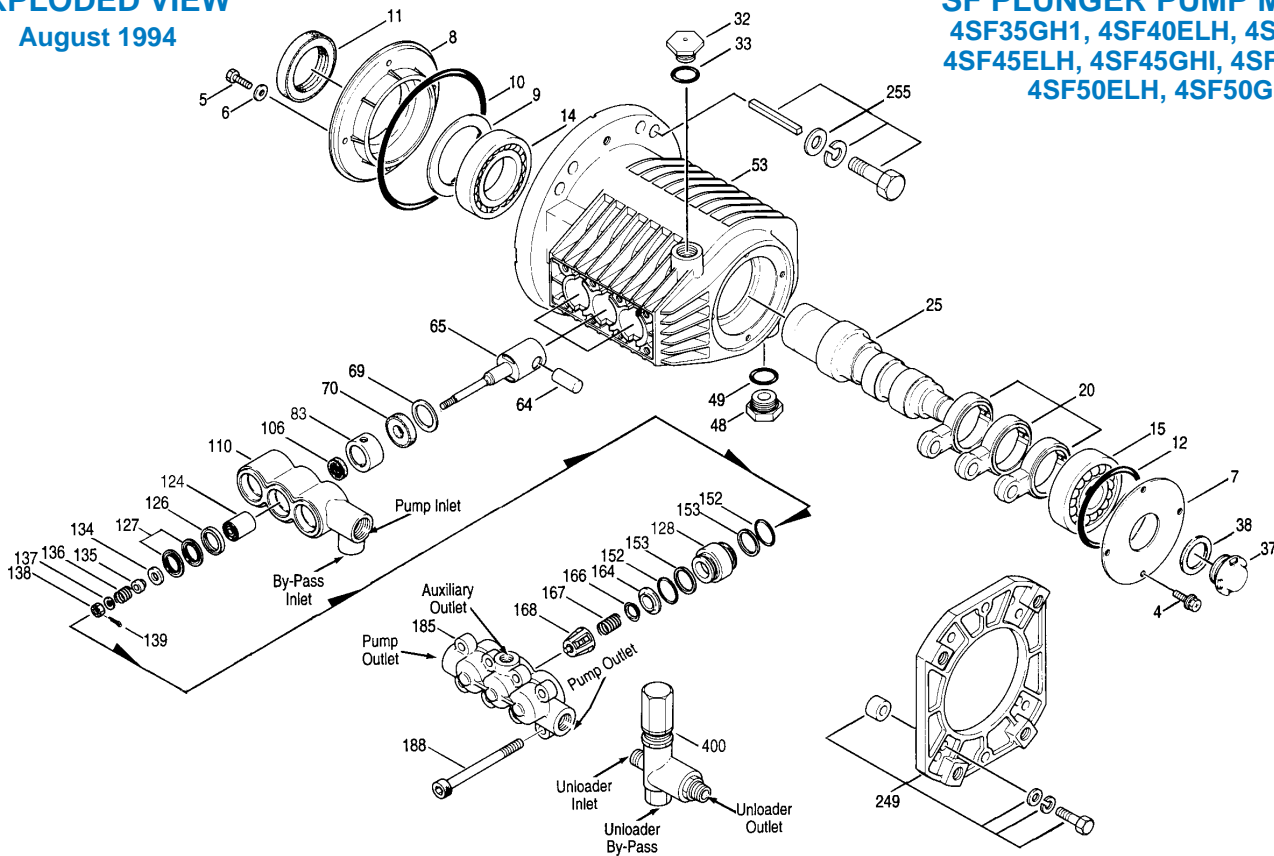

SF PLUNGER PUMP MODELS

4SF35GH1, 4SF40ELH, 4SF40GH1,
4SF45ELH, 4SF45GHI, 4SF45GH118
4SF50ELH, 4SF50GH1

PARTS LIST

ITEM	PART NO.	DESCRIPTION	MODEL USED	QTY	ITEM	PART NO.	DESCRIPTION	MODEL USED	QTY
4	92519	Z Sems. Comb. Head Screw (M6x16)	All Models	4	138	27000	S Slotted Nut (M6)	All Models	3
5	92520	Z Sems. Comb. Head Screw (M6x20)	All Models	4	139	14158	S Cotterpin	All Models	3
6	150810	Sealing Washer (M6)	All Models	4	152	43781	B O-Ring, Adapter	All Models	6
7	45707	Bearing Cover	All Models	1	153	21986	T Back-Up Ring, Adapter	All Models	6
8	45172	Bearing Case—Inner	All Models	1	164	45194	S Valve Seat	All Models	3
9	45173	Washer	All Models	1	166	43721	S Valve	All Models	3
10	89811	B O-Ring, Bearing Case	All Models	1	167	43751	S Valve Spring	All Models	3
11	141852	B Oil Seal	All Models	1	168	44564	P Spring Retainer	All Models	3
12	14037	B O-Ring, Bearing Cover	All Models	1	185	45193	BB Discharge Manifold	All Models	1
14	45174	Bearing—Inner	All Models	1	188	87860	Z Hex. Socket Head Screw (M8x100)	All Models	8
15	45175	Bearing—Outer	All Models	1	249	30972	Adapter Mount Kit - Gas (Long Shaft Eng.)	35GH1, 40GH1, 45GH1, 50GH1	1
20	45572	★ Connecting Rod	All Models	3	45215	Flange			1
25	45576	★ Crankshaft (5.0mm)	4SF35GH1	1	45216	Spacer (Aluminum)			4
	45575	★ Crankshaft (5.7mm)	4SF40GH1	1	12490	Washer (M10)			4
	45574	★ Crankshaft (6.5mm)	4SF45GH1	1	12503	Split Lock Washer (M10)			4
	45573	★ Crankshaft (6.5mm)	4SF45GH118	1	44968	Hex Head Screw (3/8-16x38)			4
	45571	★ Crankshaft (9.7mm)	4SF40ELH	1	● 255	30518	Bolt Mount Kit - Gas	35GH1, 40GH1, 45GH1, 50GH1	1
	45570	★ Crankshaft (11.1mm)	4SF45ELH	1	19891	Washer (M12)			4
	45741	★ Crankshaft (11.5mm)	4SF50ELH	1	12508	Split Lock Washer (M12)			4
	46315	★ Crankshaft (7.0mm)	4SF50GH1	1	45208	Hex Head Screw (1/2-13x45)			4
32	45690	Oil Filler Cap	All Models	1	44455	Key (1/4 x 1/4 x 2-5/32) HD		Included with Pump	1
33	14179	B O-ring, Oil Filler Cap	All Models	1	87788	Set Screw			1
37	43987	Bubble Oil Gauge	All Models	1	6106	AntiSeize Lubricant			1
38	44428	Flat Flex Gasket	All Models	1	● 255	30513	Bolt Mount Kit - Electric	40ELH, 45ELH, 50ELH	1
48	44842	Drain Plug	All Models	1	19891	Washer (M12)			4
49	14179	B O-ring, Drain Plug	All Models	1	12508	Split Lock Washer (M12)			4
53	45168	A Crankcase	All Models	1	45208	Hex Head Screw (1/2-13x45)			4
64	45179	Piston Pin	All Models	3	46076	Key (1/4 x 1/4 x 2-1/2) HD		Included with Pump	1
65	45180	Piston Rod	All Models	3	87788	Set Screw			1
	45378	U Piston Rod	All Models	3	6106	AntiSeize Lubricant			1
69	26952	S Seal Washer	All Models	3	● 255	30974	★ BS Bolt Kit (Optional) (Short Shaft Eng.)	35GH1, 40GH1, 45GH1, 50GH1	1
70	27339	B Oil Seal	All Models	3	45220	Spacer (Iron)			4
83	45183	P Seal Retainer	All Models	3	45221	Hex Head Screw (3/8-16x30)			4
106	45188	B Lo-Pressure Seal	All Models	3	12503	Split Lock Washer (M10)			4
110	45187	BB Inlet Manifold	All Models	1	12940	Washer (M10)			4
124	45848	CC Plunger	All Models	3	44455	Key (1/4 x 1/4 x 2-1/2)		Included with Pump	1
126	45190	BB Female Adapter	All Models	3	87788	Set Screw			1
127	45191	B V-Packing	All Models	6	306	34054	Seal Kit (Incls: 106, 127, 139, 152)	All Models	1
128	45192	BB Male Adapter-Spacer	All Models	3	310	34055	Valve Kit (Incls: 152, 153, 164, 166, 167, 168)	All Models	1
134	45845	S Inlet Valve	All Models	3	352	44050	Oil Gauge Removal Tool	All Models	1
135	44871	S Spacer	All Models	3	400	7600	Regulating Unloader	All Models	1
136	45186	S Inlet Valve Spring	All Models	3					
137	88575	S Conical Washer (M6)	All Models	3					

★ Items must be replaced as a set. When servicing units prior to these Mfg. dates: 008 [40EL] D88 [45EL] 888 [35GH1] 888 [40GH1] 888 [45GH1] 088 [45GH118]

● See Tech Bulletin #57 for additional information on set screw. Effective with Mfg. dates: 291 (40EL), 191 (45EL), 291 (50EL), 591 (35GH1), D90 (40GH1), 291 (45GH1).

★★ Substitute special BS Bolt Kit when Briggs-Stratton engine is used. Installation of a shaft retaining bolt, Flat washer and Lockwasher is also recommended when using the Briggs-Stratton engine to secure key.

MATERIAL CODES (Not Part of Part Number): A=Aluminum B=Buna N BB=Brass CC=Ceramic P=PVDF S=304SS SS= 316SS T=Teflon U=Unchromed Z=Zinc Plated

UNLOADER SPECIFICATIONS

	U.S. Measure	Metric Measure
GPM	2.0-5.0 GPM	(8-19 L/M)
PSI	700-3000 PSI	(50-210 BAR)
Inlet port - rear	3/8" NPT	(3/8" NPT)
Discharge port - front	3/8" NPT	(3/8" NPT)
By-Pass port - bottom	3/8" NPT	(3/8" NPT)
Weight	21.4 oz.	(0.65 L)
Dimensions	3.25" x 1.0" x 4.81"	(76 x 25 x 108mm)

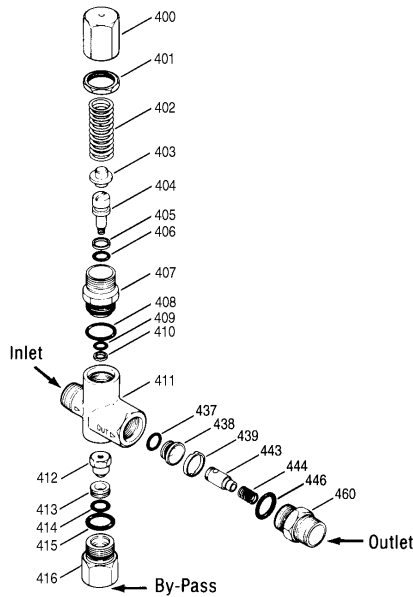

ITEM	PART NO.	DESCRIPTION	QTY.
311	32098	O-Ring Kit (Incls: 405,406,408,409,410,414,415,437)	1
362	7141	Thermo Valve - Optional	1
400	45197	BB Hex Adjusting Cap	1
401	45201	Lock Nut (M25 x 1) (Included)	1
402	45198	Coil Spring-3000 PSI	1
403	45199	BB Spring Retainer	1
404	45694	BB Piston Stem - M5	1
405	20184	T Back-Up Ring	1
406	14190	B O-ring, Piston Stem	1
407	45200	BB Piston Retainer	1
408	26133	B O-Ring, Piston Guide	1
409	14759	B O-Ring, Body	1
410	107675	T Back-Up Ring	1
411	45196	BB Body	1
412	45716	S Valve and Ball Assembly - M5	1
413	107680	S Valve Seat	1
414	13963	B O-Ring, Valve Seat	1
415	26133	B O-Ring, Adapter	1
416	45695	BB By-Pass Fitting - 3/8" NPT	1
418	7091	By-Pass Hose - 24" - Optional	1
427	7091.41	By-Pass Hose w/Thermo Valve - Optional	1
437	26127	B O-Ring, Seat	1
438	45206	S Seat	1
439	45205	Collar	1
443	45203	BB Flow Balancer w/o-ring	1
444	45924	Spring - 85G	1
446	26133	B O-Ring, Discharge Fitting	1
460	107681	BB Discharge Fitting - 3/8" NPT	1

OPERATION

A Regulating Unloader comes with each SF pump to provide system pressure regulation and pump protection.

For **MAXIMUM SUCTION** capability, Regulating Unloader should be remounted on discharge manifold, **OPPOSITE** from pump inlet port.

By-pass for the regulating unloader may drain to the ground, drain to a reservoir or connect to the special 1/4" by-pass port on the underside of the inlet manifold. A 3/8" flexible hose is recommended.

BY-PASS HOSE ASSEMBLY is designed for cold water or ambient temperature operation. **DO NOT EXCEED 6 MINUTES in BY-PASS** operation. Excessive temperatures will cause premature wear or damage to the pump and **VOID THE WARRANTY**.

When returning the by-pass back to the inlet of the pump a **Thermo Valve** should be installed in the by-pass line.

If unit is **INFREQUENTLY USED OR PERIODICALLY STORED**, seals may become dry. **UNDER SUCTION FEED**, system must be **PURGED BEFORE OPERATION** (system fluid must flow through the pump without discharge restriction) to assure full system pressure is reached.

CHEMICAL INJECTOR SPECIFICATIONS

	7123	7124
Flow	3-4 GPM	4-5 GPM
Nozzle Orifice.....	2.1mm	2.3mm
Hose Barb	1/4"	1/4"
Inlet port	3/8" NPTM	3/8" NPTM
Discharge port.....	3/8" NPTM	3/8" NPTM
Dimensions	2" x 1" x 3"	2" x 1" x 3"
Weight.....	6.3 oz.	6.3 oz.

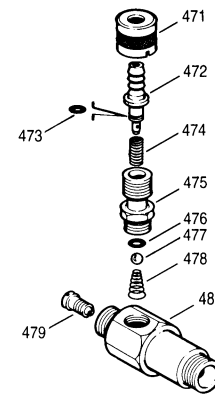

ITEM	PART NO.	DESCRIPTION	MODEL USED	QTY.
471	—	BB Adjustment Collar	All Models	1
472	—	BB Hose Barb	All Models	1
473	33503	B O-Ring	All models	1
474	33500	S Spring	All Models	1
475	33506	BB Ball Seat Retainer	All Models	1
476	33504	V O-Ring	All Models	1
477	33502	SS Ball	All Models	1
478	33501	SS Spring	All Models	1
479	32373	S Injector Orifice (2.1mm) Opt.	7123	1
	32374	Injector Orifice (2.3mm) Stnd.	7124	1
480	—	BB Body-Unloader Mount	All Models	1
481	33481	BB Adjustable Barb Assembly (Incls: 430,431,433,434)	All Models	1
482	33480	BB Fixed Barb Assy - Optional	All Models	1

CHEMICAL INJECTOR PERFORMANCE CHART

Desired Pump Flow	Injector Orifice Size	SF Injector Model	Lo-Pressure Nozzle (Maximum injecting pressure less hose friction loss)	Max. Chem. Draw (0 PSI) (Downstream)	Hi-Press Nozzle "Deduction" (Press. drop across Inj.)
3.5	2.1 mm	7123 (7113)	300 PSI	50 oz/min	200 PSI
3.5	2.3 mm	7124 (7114)	185 PSI	56 oz/min	175 PSI
4.0	2.1 mm	7123 (7113)	375 PSI	54 oz/min	250 PSI
4.0	2.3 mm	7124 (7114)	225 PSI	50 oz/min	225 PSI
4.5	2.1 mm	7123 (7113)	485 PSI	54 oz/min	325 PSI
4.5	2.3 mm	7124 (7114)	260 PSI	50 oz/min	285 PSI
5.0	2.3 mm	7124 (7114)	300 PSI	50 oz/min	350 PSI

Optimum performance of chemical injector occurs with a 35 ft. high pressure hose and a minimum 3/8" I.D. The type of hose, extended lengths, reduced I.D. and fittings may create back pressures in excess of the low pressure nozzle rating and prevent the injector from drawing chemical. **Deduct hose friction loss from above low PSI Nozzle.** Consult factory for assistance with other options.

HOSE FRICTION LOSS CHART

Water* Flow Gal/Min	PRESSURE DROP IN PSI 100 FT OF HOSE WITH TYPICAL WATER FLOW RATES				
	Hose Inside Diameter, Inches				
	1/4	5/16	3/8	1/2	5/8
3	380	120	50	13	4
4		220	90	24	7
5		320	130	34	10

An optional, **specialty ported chemical injector** may be mounted directly to the discharge of the unloader. Remove o-ring, check valve and spring from discharge fitting of unloader; insert into injector and thread into unloader discharge port. **Discard o-ring and discharge fitting.** Refer to the performance chart to determine the orifice size best suited to the system flow. **Chemical draw occurs under low pressure.** Select the Dual Nozzle (32149), Adjustable Nozzle (32151), or Vari-Nozzle (36666-72) to permit the adjustment from low to high pressure.

For optimum performance when using a chemical injector, use a **single wire braid hose** on the discharge line. Too flexible a hose will prevent the unloader from receiving the full pressure signal to activate the by-pass mode.

For correct nozzle selection, **read system pressure at the pump. DO NOT READ SYSTEM PRESSURE AT THE HIGH PRESSURE GUN.** Incorrect pressure reading may result in: pump operation at excessive pressures, inconsistent chemical draw or possible damage to the pump or unloader.

MOTOR SPECIFICATIONS

Model 8041

Horsepower	5.0 H.P.
Frame Size	184 TC TEFC
Phase	Single
Max. Volts	230 V
Amps	26.0 AMPS.
RPM	1725 RPM
Weight	93 lbs.
Capacitor Start	Yes
Service Factor	1.0

Model 8043

Horsepower	7.5 H.P.
Frame Size	215 TCZ TEFC w/184C FACE
Phase	Single
Max. Volts	208/230 V
Amps	34/31 AMPS.
RPM	1725 RPM
Weight	136 lbs.
Capacitor Start	Yes
Service Factor	1.15

Model 8046

Horsepower	10.0 H.P.
Frame Size	215 TCZ TEFC w/184C FACE
Phase	Three
Max. Volts	208/230/460 V
Amps	28/26/13 AMPS.
RPM	1725 RPM
Weight	167 lbs.
Service Factor	1.15

Model 8042

Horsepower	5.0 H.P.
Frame Size	184 TC TEFC
Phase	Three
Max. Volts	208/230/460 V
Amps	15/13.2/6/6 AMPS.
RPM	1725 RPM
Weight	76 lbs.
Service Factor	1.0

Model 8044

Horsepower	7.5 H.P.
Frame Size	215 TCZ TEFC W/184C FACE
Phase	Three
Max. Volts	208/230/460 V
Amps	21.5/20/10 AMPS.
RPM	1725 RPM
Weight	123 lbs.
Service Factor	1.15

Common Motor Specifications

Thermal Overload-Manual Reset	No
Cycle	60 HZ
Max. Operating Temp.	104°F
Shaft Diameter	1-1/8"
U.L. Reference	E-46145
CSA Reference No.	LR-2265

★ ★ Before mounting pump on motor, apply P.N. 6106 Antiseize Lubricant to pump shaft.

★ ★ Refer to Tech Bulletin #55 for instructions on removing pump from gas engine or electric motor.

MOTOR WARRANTY

All electric motors are warranted by the manufacturer to be free from defects of material and workmanship for one year from date of shipment. For warranty consideration contact Cat Pumps for the local **Authorized Baldor Service Center** or call direct to Baldor 501-646-4711 for assistance. If you are uncertain as to the cause of failure (Pump or Motor), secure **Returned Goods Authorization number** and return complete assembly **PREPAID** to Cat Pumps for evaluation.

DETERMINING	$\frac{\text{GPM} \times \text{PSI}}{1460} =$	Electric Brake
THE REQUIRED H.P.		H.P. Required

DIMENSIONAL

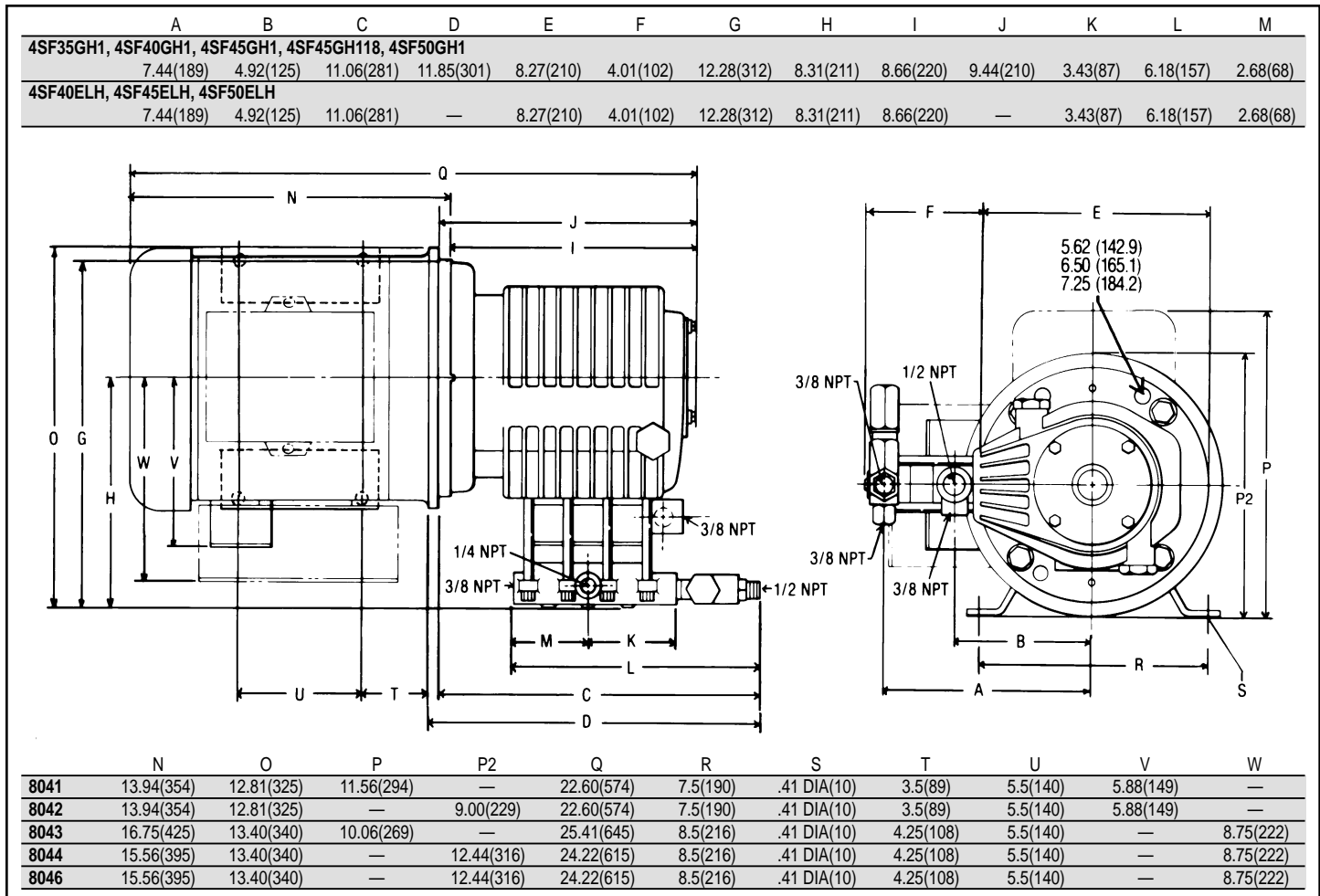

Products described hereon are covered by one or more of the following U.S. patents 3558244, 3652188, 3809508, 3920356, 3930756 and 5035580

Aug 1994 8457



CAT PUMPS U.S.A.
1681 - 94th Lane N.E. Minneapolis, MN 55449 - 4324
Phone (612) 780-5440 — Fax (612) 780-2958

• N.V. CAT PUMPS INTERNATIONAL S.A. •
Gemzenstraat 2 Wilrijk
B 2610 Antwerp, Belgium
Phone +32-(0)3-449.39.70 — Fax +32-(0)3-449.39.76

• CAT PUMPS — A.G. •
Loretöhöhe 5
CH-6300 ZUG, Switzerland
Phone 41 42 213140 — Fax 41 42 218133 — Telex 865 160 cpag ch

• CAT PUMPS DEUTSCHLAND GmbH •
Buchwiese 2
D-65510 Idstein, Germany
Phone 49 6126-9303-0 — Fax 49 6126-9303-33

• CAT PUMPS (U.K.) LTD. •
1 Fleet Business Park
Sandy Lane, Church Crookham
FLEET, Hampshire GU13 0BF, England
Phone Fleet 44 1252-622031 — Fax 44 1252-626655

Distributed By: