

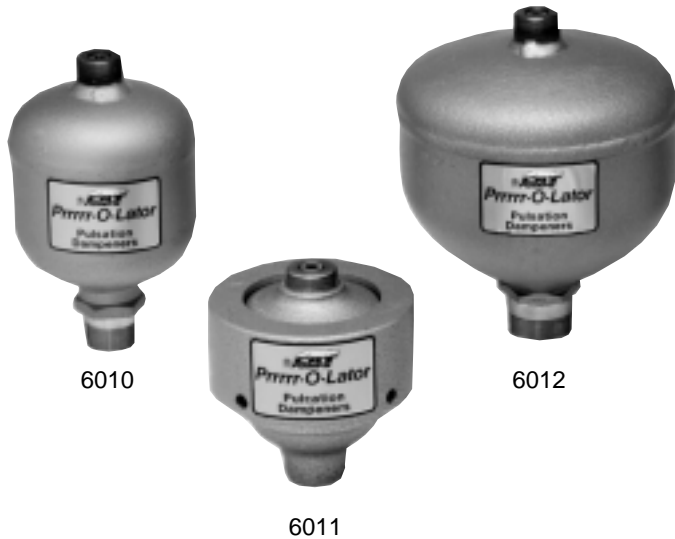

Rechargeable Prrrrr-o-lator Pulsation Dampeners

Models 6010 6011, 6012



SPECIFICATIONS

U.S. Measure

Metric Measure

MODEL 6010

Maximum Flow	40 GPM*	(151 L/M)
Maximum Working Pressure	3000 PSI**	(210 BAR)
Precharge	450 PSI	(31 BAR)
Bladder Construction	NBR	(NBR)
Maximum Operating Temperature	180°F**	(82°C)
Volume45 cu. in.	(0.75 L)
Safety Factor	4/1	(4/1)
Port Size	1" NPTM	(1" NPTM)
Diameter	4.44"	(113 mm)
Length	7.79"	(198 mm)
Weight	7.28 lbs.	(3.3 kg)

MODEL 6011

Maximum Flow25 GPM*	(95 L/M)
Maximum Working Pressure	7200 PSI***	(500 BAR)
Precharge	2000 PSI	(140 BAR)
Bladder Construction	NBR	(NBR)
Maximum Operating Temperature	180°F**	(82°C)
Volume15 cu. in.	(0.25 L)
Safety Factor	4/1	(4/1)
Port Size	1/2" NPTF	(1/2" NPTF)
Diameter	4.5"	(115 mm)
Length	5.59"	(142 mm)
Weight	6.4 lbs.	(2.9 kg)

MODEL 6012

Maximum Flow70 GPM*	(265 L/M)
Maximum Working Pressure	1500 PSI	(105 BAR)
Precharge	450 PSI	(31 BAR)
Bladder Construction	NBR	(NBR)
Maximum Operating Temperature	180°F	(82°C)
Volume	120 cu. in.	(1.97 L)
Safety Factor	4/1	(4/1)
Port Size	1-1/4" NPTM	(1-1/4" NPTM)
Diameter	6.7"	(172 mm)
Length	8.5"	(217 mm)
Weight	12.0 lbs.	(5.44 kg)

*Authorized system performance. Contact CAT PUMPS for continuous duty performance.

**2500 PSI maximum working pressure at 180°F temperature.

***6000 PSI maximum working pressure at 180°F temperature.

NOTE: To order a different precharge than stated, add .800 to model number and specify desired precharge.

Material Codes (Not Part of Part Number): NBR=Medium Nitrile (Buna-N)

FEATURES

- Poppet reinforced bladder for durability.
- Nitrogen precharged to eliminate moisture and bladder deterioration.
- Convenient bottom port for easy mounting directly onto discharge manifold.
- Sealed valve for positive pressure lock
- Reduces pulsation to $\pm 3\%$ to prolong life of pump and system components.

“Customer confidence is our greatest asset”

INSTALLATION INSTRUCTIONS

SELECTION: The Prrrrr-O-Lator should be selected to match the flow and pressure requirements of the system and satisfy the liquid compatibility.

INSTALLATION: The Prrrrr-O-Lator should be mounted directly onto the pump discharge manifold for optimum pulsation dampening and to avoid system vibration damage. Before installing the pulsation dampener, be certain the sealed valve at the top of the accumulator is securely tightened to assure no loss of pressure during operation.

OPERATION: The Prrrrr-O-Lator should be precharged with **dry Nitrogen only**.

⚠ WARNING

Never use oxygen or air. This could cause an explosion.

Note the standard precharge of the Prrrrr-O-Lator. This may be adjusted to offer a more precise control of pulsation in critical applications such as reverse osmosis. Check this precharge every 12 months for normal operation and more frequently for continuous-duty operation.

At a standard temperature of 70°F (20°C), optimum accumulator performance is obtained when the precharge is calibrated at 50% of the system operating pressure.

NOTE

When operating at the lower temperatures, precharge should be 15% higher or 65% of system pressure. When operating at higher temperatures, precharge should be 15% lower or 35% of system pressure.

NOTE

Up to 50 PSI precharge pressure can be lost during the checking of your precharge.

CAUTION

A gas regulator must be mounted between the nitrogen tank and the hose connection from the Filling and Gauging Assembly to enable you to regulate 50% of the desired system pressure and to prevent excessive pressure being transmitted directly to the accumulator. **THIS OVER PRESSURIZATION WILL VOID THE WARRANTY.**

DIMENSIONAL

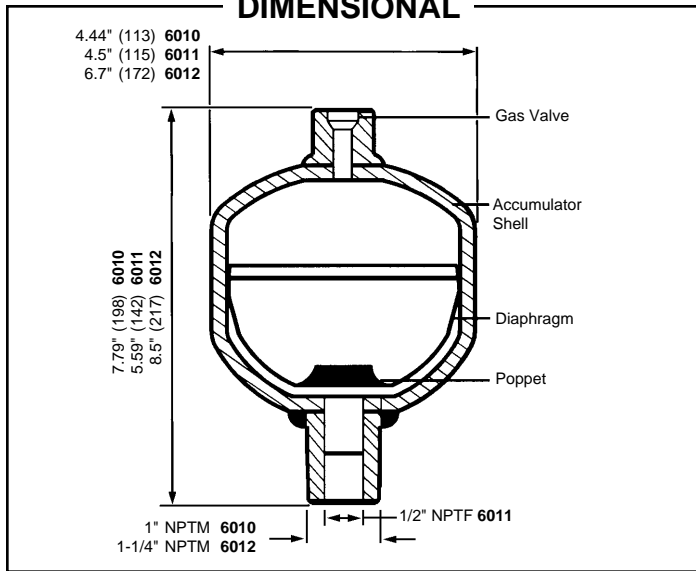

Products described hereon are covered by one or more of the following U.S. patents 3558244, 3652188, 3809508, 3920356, 3930756 and 5035580

FILLING AND GAUGING INSTRUCTIONS

The following are the steps in both checking the precharge of the accumulator and recharging if there should be a loss of pressure or a need for adjustment.

1. Before checking your precharge, **system pressure should be at zero**. TURN SYSTEM OFF.
2. SLIGHTLY loosen the sealed valve at the top of the accumulator using a 6mm long handled allen wrench. Thread on the Filling and Gauging Assembly hand tight.
3. Be certain the SIDE BLEED VALVE on the gauging assembly is CLOSED.
4. Slowly open the LARGE "T" VALVE at the top of the gauging assembly until completely open. The gauge on the assembly will read the precharge on the accumulator.
5. Completely back off (CLOSE) the valve on the gas regulator, open the nitrogen tank valve and read the nitrogen tank pressure on the first gauge.
6. If the reading on the gauge assembly is 50% of the system pressure, close the top "T" valve and proceed to step 9.
7. If the precharge is too high, keep the top "T" valve open and slowly open the small "T" valve on the side of the gauging assembly to bleed of pressure.
8. If the pressure is less than 50% of the system pressure, slowly open the gas regulator valve until the desired precharge is reached on the second gauge.
9. When the gauge reads the required precharge, close the "T" valve on the top of the gauging assembly to lock the precharge in the accumulator.
10. Back off (CLOSE) the gas regulator.
11. Proceed with opening the small side "T" valve on the gauging assembly to relieve (bleed-off) pressure in the assembly and on the second gauge on the gas regulator.
12. Close the side "T" valve on the gauging assembly and remove the assembly from the accumulator.
13. Tighten the accumulator sealed valve and resume operation.

30940 Complete Filling and Gauging Assembly (Optional)

30941 Allen Wrench (Included in Assembly)

6099 Pressure Gauge (Included in Assembly)



World Headquarters

CAT PUMPS

1681 - 94th Lane N.E. Minneapolis, MN 55449-4324

Phone (763) 780-5440 — FAX (763) 780-2958

e-mail: techsupport@catpumps.com

www.catpumps.com

International Inquiries

FAX (763) 785-4329

e-mail: intl@catpumps.com



The Pumps with Nine Lives

CAT PUMPS (U.K.) LTD.

1 Fleet Business Park, Sandy Lane, Church Crookham

FLEET, Hampshire, GU52 8BF, England

Phone Fleet 44 1252-622031 — Fax 44 1252-626655

e-mail: sales@catpumps.co.uk www.catpumps.co.uk

N.V. CAT PUMPS INTERNATIONAL S.A.

Heiveldkens 6A, B-2550 Kontich, Belgium

Phone 32-3-450.71.50 — Fax 32-3-450.71.51

e-mail: cpi@catpumps.be www.catpumps.be

CAT PUMPS DEUTSCHLAND GmbH

Buchwiese 2, D-65510 Idstein, Germany

Phone 49 6126-9303 0 — Fax 49 6126-9303 33

e-mail: catpumps@t-online.de www.catpumps.de