



## Stainless Steel Rechargeable Pulsation Dampener

**Models**                    **6013**  
**6014, 6015**

### FEATURES

- Nitrogen precharged to eliminate moisture and bladder deterioration.
- Convenient bottom port for easy mounting directly onto discharge manifold.
- Sealed valve for positive pressure lock.
- 316 Stainless Steel housing for special compatibility.
- Adjustable precharge with optimum setting at 50% of system pressure.

### SPECIFICATIONS

	U.S. Measure	Metric Measure
<b>MODEL 6013</b>		
Maximum Flow .....	40 GPM	(151 L/M)
Maximum Working Pressure .....	2000 PSI	(140 BAR)
Precharge .....	450 PSI	(30 BAR)
Temperature Range .....	+5° to 180°F	(-15 to 82°C)
Volume .....	.45 cu. in.	(0.74 L)
Safety Factor .....	4/1	(4/1)
Bladder Construction .....	<b>FPM</b>	<b>(FPM)</b>
Port Size .....	1" NPTM	(1" NPTM)
Diameter .....	4.44"	(113 mm)
Length .....	7.79"	(198 mm)
Weight .....	6.28 lbs.	(2.8 kg)
<b>MODEL 6014</b>		
Maximum Flow .....	25 GPM	(95 L/M)
Maximum Working Pressure .....	2400 PSI	(170 BAR)
Precharge .....	450 PSI	(30 BAR)
Temperature Range .....	+5° to 180°F	(-15 to 82°C)
Volume .....	.20 cu. in.	(0.328 L)
Safety Factor .....	4/1	(4/1)
Bladder Construction .....	<b>NBR</b>	<b>(NBR)</b>
Port Size .....	3/4" NPTM	(3/4" NPTM)
Diameter .....	3.66"	(93 mm)
Length .....	5.91"	(150 mm)
Weight .....	2.9 lbs.	(1.31 kg)
<b>MODEL 6015</b>		
Maximum Flow .....	70 GPM	(265 L/M)
Maximum Working Pressure .....	1500 PSI	(105 BAR)
Precharge .....	450 PSI	(30 BAR)
Temperature Range .....	+5° to 180°F	(-15 to 82°C)
Volume .....	120 cu. in.	(1.97 L)
Safety Factor .....	4/1	(4/1)
Bladder Construction .....	<b>NBR</b>	<b>(NBR)</b>
Port Size .....	1-1/4" NPTM	(1-1/4" NPTM)
Diameter .....	6.30"	(160 mm)
Length .....	9.0"	(229 mm)
Weight .....	9.3 lbs.	(4.2 kg)

*"Customer confidence is our greatest asset"*

## INSTALLATION INSTRUCTIONS

**SELECTION:** The Prrrrr-O-Lator should be selected to match the flow and pressure requirements of the system and satisfy the liquid compatibility.

**INSTALLATION:** The Prrrrr-O-Lator should be mounted directly onto the pump discharge manifold for optimum pulsation dampening and to avoid system vibration damage.

**OPERATION:** The Prrrrr-O-Lator should be precharged with **dry Nitrogen only**.

### ⚠ WARNING

Never use oxygen or air. This could cause an explosion.

The Prrrrr-O-Lator is standardly precharged to 450 PSI, however, it may be adjusted to offer a more precise control of pulsation in critical applications such as reverse osmosis.

At a standard temperature of 70°F, optimum accumulator performance is obtained when the precharge is calibrated at 50% of the system operating pressure.

### NOTE

When operating at the lower temperatures, precharge should be 15% higher or 65% of system pressure. When operating at higher temperatures, precharge should be 15% lower or 35% of system pressure.

This precharge should be checked every 12 months for normal operation and more frequently for continuous-duty operation.

### NOTE

Up to 50 PSI precharge pressure can be lost during the checking of your precharge.

## DIMENSIONAL

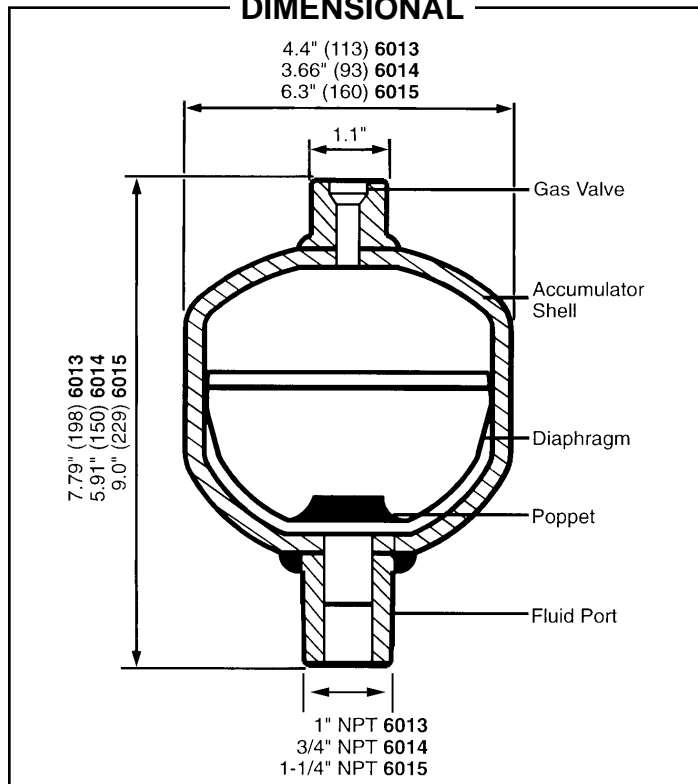

Products described hereon are covered by one or more of the following U.S. patents 3558244, 3652188, 3809508, 3920356, 3930756 and 5035580

## FILLING AND GAUGING INSTRUCTIONS

The following are the steps in both checking the precharge of the accumulator and recharging if there should be a loss of pressure or a need for adjustment.

1. Before checking your precharge, **system pressure should be at zero**. TURN SYSTEM OFF.
2. SLIGHTLY loosen the sealed valve at the top of the accumulator using a 6mm long handled allen wrench. Thread on the Filling and Gauging Assembly hand tight.
3. Be certain the SIDE BLEED VALVE on the gauging assembly is CLOSED.
4. Slowly open the LARGE "T" VALVE at the top of the gauging assembly until completely open. The gauge on the assembly will read the precharge on the accumulator.
5. Completely back off (CLOSE) the valve on the gas regulator, open the nitrogen tank valve and read the nitrogen tank pressure on the first gauge.
6. If the reading on the gauge assembly is 50% of the system pressure, close the top "T" valve and proceed to step 9.
7. If the precharge is too high, keep the top "T" valve open and slowly open the small "T" valve on the side of the gauging assembly to bleed of pressure.
8. If the pressure is less than 50% of the system pressure, slowly open the gas regulator valve until the desired precharge is reached on the second gauge.
9. When the gauge reads the required precharge, close the "T" valve on the top of the gauging assembly to lock the precharge in the accumulator.
10. Back off (CLOSE) the gas regulator.
11. Proceed with opening the small side "T" valve on the gauging assembly to relieve (bleed-off) pressure in the assembly and on the second gauge on the gas regulator.
12. Close the side "T" valve on the gauging assembly and remove the assembly from the accumulator.
13. Tighten the accumulator sealed valve and resume operation.

- 30940 Complete Filling and Gauging Assembly (Optional)
- 30941 Allen Wrench (Included in Assembly)
- 6099 Pressure Gauge 1/8" BSP, 3500 PSI Backmount (Included in Assembly)



### World Headquarters

#### CAT PUMPS

1681 - 94th Lane N.E. Minneapolis, MN 55449-4324

Phone (763) 780-5440 — FAX (763) 780-2958

e-mail: techsupport@catpumps.com

www.catpumps.com

### International Inquiries

FAX (763) 785-4329

e-mail: intlsales@catpumps.com



The Pumps with Nine Lives

### CAT PUMPS (U.K.) LTD.

1 Fleet Business Park, Sandy Lane, Church Crookham

FLEET, Hampshire, GU52 8BF, England

Phone Fleet 44 1252-622031 — Fax 44 1252-626655

e-mail: sales@catpumps.co.uk

### N.V. CAT PUMPS INTERNATIONAL S.A.

Heiveldkens 6A, B-2550 Kontich, Belgium

Phone 32-3-450.71.50 — Fax 32-3-450.71.51

e-mail: cpi@catpumps.be www.catpumps.be

### CAT PUMPS DEUTSCHLAND GmbH

Buchwiese 2, D-65510 Idstein, Germany

Phone 49 6126-9303 0 — Fax 49 6126-9303 33

e-mail: catpumps@t-online.de www.catpumps.de