



Pulse Pump Injector Head

Model

6300

Use with 6400, 6410, 6425
Pulse Pump Manifolds

Model

6305

Use with 6410, 6425
Pulse Pump Manifolds

FEATURES

- Chemical resistant 316 stainless steel upper body with chrome plated brass lower body.
- STG/NBR laminated diaphragm offers resilience and chemical compatibility.
- Conveniently mounts directly onto the discharge manifold drawing chemical with each stroke of the pump.
- Patented single port purge valve purges air from head and case simultaneously.
- Permits chemical application at system pressures up to 1000 PSI.

SPECIFICATIONS

	U.S. Measure	Metric Measure
MODEL 6300		
Pressure Rating	1000 PSI	(70 Bar)
Maximum Flow*	1 Qt./Min.	(1 L/M)
Inlet/Discharge Ports	1/4"-18 NPT	(1/4"-10 NPT)
Manifold Port	1/2"-14 NPTM	(1/2"-14 NPTM)
Weight	2.7 Lbs.	(1.22 kg)
Dimensions	4.3 x 2.6 x 5.9"	(109 x 66 x 149.8 mm)
MODEL 6305		
Pressure Rating	1000 PSI	(70 Bar)
Maximum Flow*	1 Gal./Min.	(3 L/M)
Inlet/Discharge Ports	3/8"-18 NPT	(3/8"-10 NPT)
Manifold Port	3/4"-14 NPTM	(3/4"-14 NPTM)
Weight	6.0 Lbs.	(2.72 kg)
Dimensions	7.0 x 6.3 x 6.0"	(177.8 x 160 x 152.4 mm)

*Flow will vary according to flow and pressure of drive pump. For optimum performance **inlet pressure to the pump** should be zero or negative but **not to exceed pump specifications.**

INSTALLATION INSTRUCTIONS

MODEL 6400: Remove the STANDARD manifold from the pump. Remove valve assemblies from the manifold. Examine special PULSE PUMP MANIFOLD. Note which cylinder had the deeper counterbore in the valve chambers. This is the pulse pump cylinder. Install one seal washer and discharge valve retainer (without nylon insert) in this port. Install **special heavy spring**, standard valve spring, valve, seat and port ring. In other two chambers, install one seal washer. Then exchange standard valve

parts with **Flat Valve** assemblies (only flat valve assembly can be used). Before reinstalling manifold on pump, remove existing shims from each cylinder bolt. The number of shims may change with manifolds. Refer to Tech Bulletin 017 for proper shimming procedure. Torque nuts to 140 in/lbs. (16 Nm).

Thread pulse pump into special port on the discharge manifold. Install piping according to diagram.

(continued on back)

“Customer confidence is our greatest asset”

PARTS LIST

Pulse Pump

MODEL 6300

(1 QT per MIN. @ 800 RPM, 1000 PSI)

Converted Pump Models 335, 435, 825, 1015, 1525, 2525

ITEM	P/N	MATL	DESCRIPTION	QTY.
17	28412	BB	Nipple, Hex (1/2")	1
20	28414	BB	Case, Diaphragm	1
21	28574		Assembly, Diaphragm	1
	* 26867	NBR	Diaphragm	1
	* —	SS	Stem Guide	1
	* —	SS	Retaining Washer	1
	* 81240	SS	Nut, Hex (M6)	1
24	27549	SS	Spring, Diaphragm	1
25	27550	S	Nut, Special (M6)	1
26	81240	SS	Nut, Hex (M6)	1
27	28416	SS	Orifice	1
28	28415	SS	Head, Diaphragm	1
31	28417	S	Valve, Needle	1
32	21549	NBR	O-Ring	1
34	27557	SS	Retainer, Spring	2
35	46026	SS	Spring, Check Valve	2
36	26882	S	Valve, Check	2
37	19285	NBR	O-Ring, Valve - 70D	2
38	27556	S	Seat	2
	88145	SS	Bolt, HH (M10)	4
	88072	S	Washer, Conical (M10)	4
	81045	STZP	Nut, Hex (M10 x 1.25), Head	4

* Included in Diaphragm Assembly

MODEL 6305

(1 Gal. per Min. @ 800 RPM, 1000 PSI)

Converted Pump Models 825, 1015, 1525, 2525

ITEM	P/N	MATL	DESCRIPTION	QTY.
17	29062	BB	Nipple, Hex (3/4")	1
20	29025	BB	Case, Diaphragm	1
21	29019	—	Assembly, Diaphragm	1
	29023	NBR	Diaphragm only	1
24	29060	SS	Spring, Diaphragm	1
25	29061	S	Nut, Special (M8)	1
26	81249	SS	Nut, Hex (M8)	1
27	28416	SS	Orifice	1
28	—	SS	Head, Diaphragm	1
31	28417	S	Valve, Needle	1
32	21549	NBR	O-Ring	1
34	29028	SS	Retainer, Spring	2
35	29029	SS	Spring, Check Valve	2
36	29037	SS	Valve, Check	2
37	14179	NBR	O-Ring, Valve - 70D	2
38	29027	S	Seat	2
	88365	STZP	Screw, HSH (M12x35)	6
	88102	S	Washer, Conical (M12)	6

Manifold

MODEL 6400

Standard Pump Models 333 and 430

ITEM	P/N	MATL	DESCRIPTION	QTY.
3	—	BB	Manifold	1
—	13533	STZP	Shim, Washer (M8x.5)	2
5	26886	S	Retainer, Spring	1
6	25676	BB	Spacer	1
7	28419	S	Spring	1
9	—	BB	Plug	1
10	11338	NBR	O-Ring, Plug - 70D	1
11	30497	PTFE	Washer, Seal	3
12	● 22031	S	Spring	1
13	● 22842	S	Valve	1
14	● 29487	S	Seat	1

MODEL 6410

Standard Pump Models 623, 820, 1010

ITEM	P/N	MATL	DESCRIPTION	QTY.
3	—	BB	Manifold	1
5	29063	S	Retainer, Spring	1
6	28542	BB	Spacer	1
7	28544	S	Spring	1
9	28543	BBCP	Plug	1
10	20285	NBR	O-Ring, Plug - 70D	1
13	28545	S	Valve	1
12	● 20265	S	Spring	1
14	● 43063	S	Seat	1
16	● 43062	PTFE	Back-Up-Ring Seat	1
18	● 26966	NBR	O-Ring, Seat - 70D	1

MODEL 6425

Standard Pump Models 1520, 2520

ITEM	P/N	MATL	DESCRIPTION	QTY.
3	—	BB	Manifold	1
5	27802.100	SS	Retainer, Spring	1
6	29032	BB	Spacer	1
7	29036	S	Spring	1
9	28543	BBCP	Plug	1
10	20285	NBR	O-Ring, Plug - 70D	1
13	29035	S	Valve	1
12	● 26548	S	Spring	1
14	● 29034	S	Seat	1
19	29033	NBR	O-Ring, Gasket-Square	1

● Bold print items are not included in the Manifold Assembly

CAUTION

When adding a pulse port manifold assembly to a pump that has QUIET VALVES, it is necessary to convert to FLAT VALVES. The diameter of the valve spring retainer for the quiet valves is too small for the helper spring.

To convert a 4 FRAME pump with QUIET VALVES to a pulse pump model, use P.N. 30024 Flat Valve Kit plus the 6400 Pulse Pump Manifold Assembly. For 10 FRAME pumps with QUIET VALVES, use P.N. 30449 FLAT VALVE KIT plus the 6410 Pulse Pump Manifold Assembly. 25 FRAME pumps are standard with FLAT VALVES.

NOTE

Remove nylon insert in retainer before installing in pulse pump manifold.

MATERIAL CODES (Not Part of Part Number):

BB=Brass BBCP=Brass/Chrome Plated NBR=Medium Nitrile (Buna-N) PTFE=Pure Polytetrafluoroethylene S=304SS SS=316SS STZP=Steel/Zinc Plated

CUTAWAY

Pulse Pump Models 6300 and 6305
and Manifold Models 6400, 6410, 6425

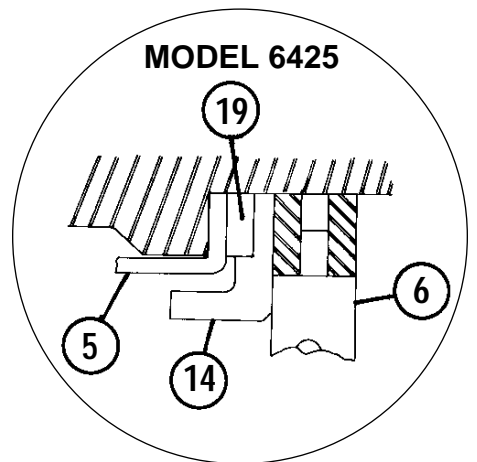
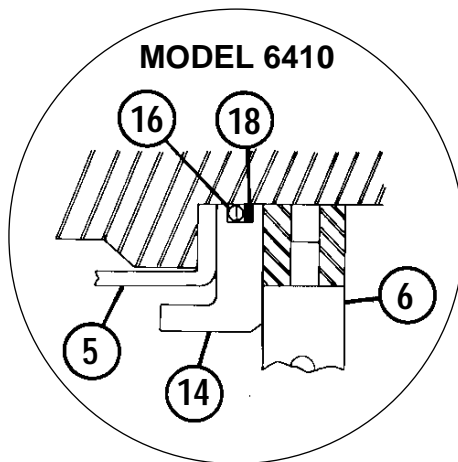
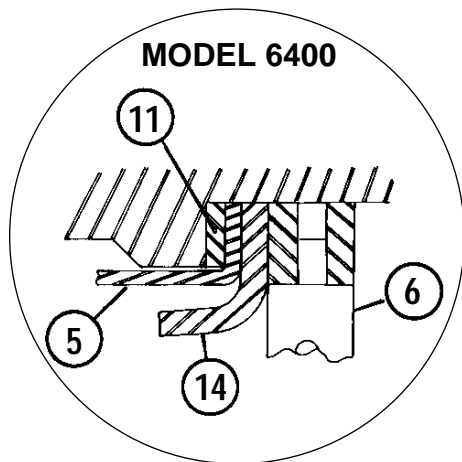
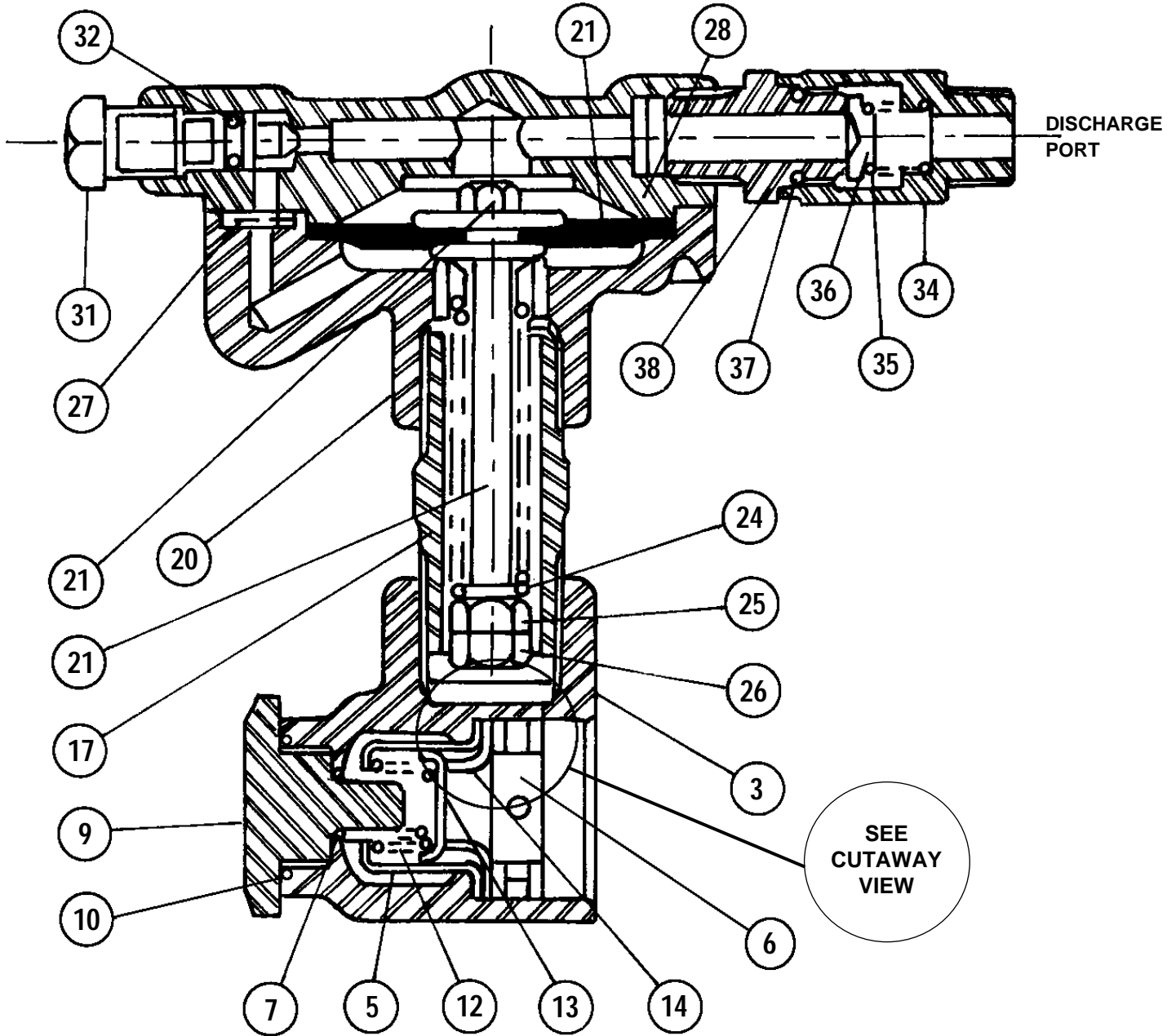

MODEL 6410: Remove the STANDARD manifold from the pump. Remove valve assemblies from the manifold. Examine special PULSE PUMP MANIFOLD. Note which cylinder has the deeper counterbore in the valve chambers. This is the pulse pump cylinder. Install the retainer in this chamber. Next install **special heavy spring**, standard spring, valve, seat and spacer. Examine o-ring and back-up ring on all seats before reinstalling. In the other two chambers, install standard **Flat Valve** assemblies (only Flat Valve assemblies can be used). Install manifold on pump, replace lockwashers and nuts and torque to 250 in/lbs. (28 Nm).

CAUTION

Any cylinder motion will cause premature failure of the cylinder o-rings. Check for center cylinder motion and exchange with one of the end cylinders.

Thread pulse pump into special port on the discharge manifold. Install piping according to diagram.

MODEL 6425: Remove the STANDARD manifold from the pump. Remove valve assemblies from the manifold. Examine special PULSE PUMP MANIFOLD. Note which cylinder has the deeper counterbore in the valve chambers. Special parts are used in this chamber, standard flat valve parts are used in the other two chambers. Install **special retainer** in this port. Next install **special heavy spring**, standard spring and **special valve**. Then install gasket on **special seat** and insert into retainer. Install spacer. Install manifold on pump, replace lockwashers and nuts and torque to 270 in/lbs. (42 Nm).

CAUTION

Any cylinder motion will cause premature failure of the cylinder o-rings. Check for center cylinder motion and exchange with one of the end cylinders.

Thread pulse pump into special port on the discharge manifold. Install piping according to diagram.

OPERATION: With gun open, start drive pump. After water starts to flow out the nozzle (minimum 200 PSI), open bleed valve ONE TURN to purge air from pulse pump, thus priming the pulse pump. After all air is purged, torque valve 120 in/lbs. (14 Nm). Then set drive pump for proper discharge pressure.

CAUTION

Pulse pump will not draw chemical with a pressurized inlet to the drive pump.

CAUTION

Do not operate the pulse pump dry. This could damage diaphragm. Check your chemical supply regularly.

NOTE

To adjust the amount of chemical drawn into the system, install a metering valve in the **discharge line of the pulse pump**. **Metering valve not supplied with pulse pump.**

After the unit is operating, adjust metering valve to obtain desired water/chemical ratio. Check chemical output by measuring chemical supply tank.

MIXING RATIO varies with output of drive pump, the model pulse pump being used and whether a metering valve is used.

MAINTENANCE: Before shutting system down, **flush** pulse pump by placing chemical supply line in water. If volume of chemical decreases, lap discharge valve, suction valve seat and valve with 440 grit paper. **CHECK DIAPHRAGM FOR LEAKS.**

When replacing the diaphragm, thread the nut onto the stem and tighten until the **nut is flush with the end of the stem**. Further tightening will prevent the diaphragm from functioning.

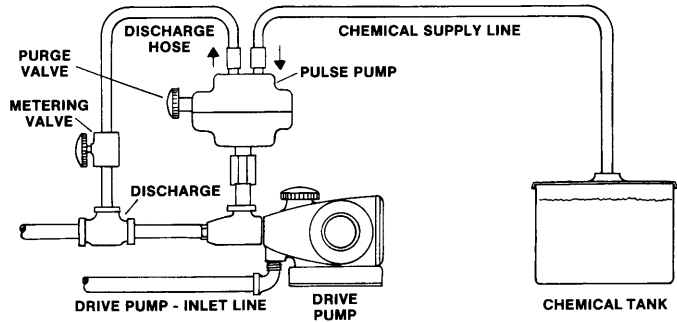

TROUBLESHOOTING

- | | |
|--|---|
| <p>No chemical supply from Pulse Pump</p> | <ul style="list-style-type: none"> • Failure of diaphragm or spring. • Air in chemical supply line. • Foreign material in inlet or discharge valves. |
| <p>Limited chemical supply from Pulse Pump</p> | <ul style="list-style-type: none"> • O-ring around push rod worn. • Clog in manifold port fitting. • Loose lock nut or diaphragm spring. • Worn inlet and discharge valves. |

Products described hereon are covered by one or more of the following U.S. patents 3558244, 3652188, 3809508, 3920356, 3930756 and 5035580

World Headquarters
CAT PUMPS
 1681 - 94th Lane N.E. Minneapolis, MN 55449-4324
 Phone (763) 780-5440 — FAX (763) 780-2958
 e-mail: techsupport@catpumps.com
 www.catpumps.com

International Inquiries
 FAX (763) 785-4329
 e-mail: intlsales@catpumps.com



CAT PUMPS (U.K.) LTD.
 1 Fleet Business Park, Sandy Lane, Church Crookham, Fleet
 Hampshire GU52 8BF, England
 Phone Fleet 44 1252-622031 — Fax 44 1252-626655
 e-mail: sales@catpumps.co.uk

N.V. CAT PUMPS INTERNATIONAL S.A.
 Heiveldkens 6A, B-2550 Kontich, Belgium
 Phone 32-3-450.71.50 — Fax 32-3-450.71.51
 e-mail: cpi@catpumps.be www.catpumps.be

CAT PUMPS DEUTSCHLAND GmbH
 Buchwiese 2, D-65510 Idstein, Germany
 Phone 49 6126-9303 0 — Fax 49 6126-9303 33
 e-mail: catpumps@t-online.de www.catpumps.de