



Pressure Sensitive Pressure Regulator

Model **7080**
 7082

FEATURES

- Provides system pressure setting and protection for single or multiple gun and pump systems.
- Compact size and easy installation.
- Immediately returns to system pressure when gun opens.
- Springs are color coded for easy valve identification and simple change from one pressure rating to another.

SPECIFICATIONS

	U.S. Measure	Metric Measure
MODEL 7080		
Flow Range	2.5-7.8 GPM	(9.5-29.5 L/M)
Pressure Range	150-1450 PSI	(10-100 BAR)
Inlet Port	3/8" NPTF	(3/8" NPTF)
Discharge Port.....	3/8" NPTF	(3/8" NPTF)
By-Pass Port	3/8" NPTF	(3/8" NPTF)
Maximum Temperature	160°F	(71°C)
Weight	1.0 lbs.	(0.45 kg)
Dimensions	3.1 x 2.0 x 6.4"	(79 x 51 x 163 mm)

MODEL 7082		
Flow Range	2.5-7.8 GPM	(9.5-29.5 L/M)
Pressure Range	850-3575 PSI	(59-246 BAR)
Inlet Port	3/8" NPTF	(3/8" NPTF)
Discharge Port.....	3/8" NPTF	(3/8" NPTF)
By-Pass Port	3/8" NPTF	(3/8" NPTF)
Maximum Temperature	160°F	(71°C)
Weight	1.0 lbs.	(0.45 kg)
Dimensions	3.1 x 2.0 x 6.4"	(79 x 51 x 163 mm)

Regulator is stamped with a European safety pressure. Use only at above specifications to assure proper regulator life and performance.

⚠ WARNING

All systems require both a primary pressure regulating device (i.e., regulator, unloader) and a secondary pressure safety relief device (i.e., pop-off valve, safety valve). Failure to install such relief devices could result in personal injury or damage to the pump or to system components. CAT PUMPS does not assume any liability or responsibility for the operation of a customer's high pressure system.

90 DAY WARRANTY

Refer to complete CAT PUMPS Warranty for further information.

“Customer confidence is our greatest asset”

SELECTION

This is a pressure sensitive pressure regulator designed for systems with single or multiple pumps, solenoid (gate) valves, nozzles, standard or "weep" guns.

Note: For multiple pump systems, it is best to use a pressure regulator not a pressure sensitive regulating unloader.

This pressure sensitive regulator should meet both the desired system flow (combined nozzle flow rate requirement) and the desired system pressure.

Note: Operation below the minimum flow of the regulator causes the regulator to cycle or chatter. Operation above the maximum flows of the regulator causes premature regulator wear, regulator cycling and prevents attaining desired system pressure.

INSTALLATION

This regulator operates properly when mounted in any direction; however, it is preferred to keep the plumbing to a minimum and the pressure adjusting nuts easily accessible. The best mounting location is directly on the pump discharge manifold head. Flexible, high pressure hose (minimum single wire braid) should be at least the size of the regulator ports when plumbing to and from the regulator.

The inlet connection on this regulator is a 3/8" NPTF sized port that is located on the bottom. There is an arrow and the word IN cast into the body indicating the direction of flow. Liquid from the pump discharge manifold goes through this connection.

The discharge connection on this regulator is a 3/8" NPTF sized port located on the front. Plumbing for the spray guns, solenoid (gate) valves or nozzles are connected to this discharge port.

The by-pass connection of this regulator is a 3/8" NPTF sized port located on the side. The word BY-PASS is cast into the body. By-Pass liquid is directed out of this port and can be routed to a reservoir (preferred method) or to a drain or back to the pump inlet.

OPERATION

This pressure sensitive pressure regulator holds established system pressure in the discharge line and at the pump head when the trigger gun is closed or solenoid (gate) valve is closed or the nozzle is clogged, thus by-passing all unrequired flow. Squeezing the trigger gun or opening the solenoid (gate) valve allows for a quick return to established system pressure without delay.

PRESSURE ADJUSTMENT

Setting the Pressure Regulator

1. Setting and adjusting the regulator pressure must be done with the system "on".
2. Start the system with regulator backed off to the lowest pressure setting (counterclockwise direction).
3. Squeeze the trigger and read the pressure on the gauge at the pump.

Note: Do not read the pressure at the gun or nozzle.

4. If more pressure is desired, release the trigger, turn bottom pressure adjusting nut one quarter turn in clockwise direction.

Note: Top nut is a locking nut and bottom nut is the adjusting nut. The brass nut located on the piston stem inside the spring is a limit stop for the spring, do not adjust.

5. Squeeze the trigger and read the pressure.
6. Repeat this process until desired system pressure is attained.
7. Once the desired system pressure is reached, stop turning the bottom pressure adjusting nut.
8. Thread the top locking nut down to the bottom adjusting nut.

Note: Locking nut is not set at the factory.

CAUTION: A minimum by-pass flow of 5% of the regulator rated flow capacity is required for proper regulator performance. If the entire output is directed through the regulator (zero by-pass) the "cushioning" feature of the by-pass liquid is eliminated and the regulator can malfunction or wear prematurely.

9. If desired system pressure cannot be reached, review TROUBLESHOOTING chart.
10. When servicing existing systems, back top locking nut away from bottom pressure adjusting nut.
11. Follow adjustment procedures as stated above for new regulators.

Note: Do not adjust regulators pressure setting to compensate for a worn nozzle. Check the nozzle as part of the regular maintenance and replace if worn.

TYPICAL REGULATOR INSTALLATION

- 1 Pressure Gauge
- 2 Relief Valve
Show as a secondary safety relief valve
- 3 Pressure Sensitive Regulator
- 4 Triplex Plunger Pump

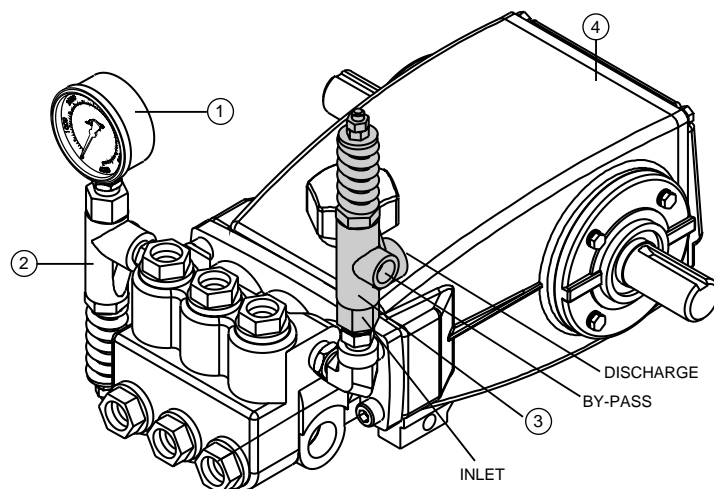

Setting the Relief Valve

1. Back off top locking nut from bottom adjusting nut of the relief valve.
2. Turn bottom adjusting nut of the relief valve in a counterclockwise direction in small increments until there is some visible liquid coming out the by-pass port.
3. Turn bottom adjusting nut of the relief valve in a clockwise direction until visible liquid stops coming out.
4. Final adjustment for the relief valve should relieve at 200 PSI above the system operating pressure.

SERVICING

CAUTION: Before commencing with service, shut off drive (electric motor, gas or diesel engine) and turn off water supply to pump. Relieve all discharge line pressure by triggering gun or opening valve in discharge line.

Disassembly

1. Disconnect by-pass, discharge and inlet plumbing from regulator.
2. Remove regulator from pump.
3. Secure regulator in a vise with spring facing up.
4. Remove top locking nut, bottom adjusting nut, spring retainer and spring. Examine pressure spring for fatigue or breaks and replace as needed.
5. Remove brass limit nut from piston stem.
6. Drive out piston lock pin from piston stem.
7. Using a 15/16" wrench remove piston retainer with o-ring. Examine o-ring for cuts or wear and replace as needed.
8. Remove piston stem with two back-up-rings and one o-ring from regulator body. The piston retainer back-up-ring and o-ring will remain on the piston stem. Examine all back-up-rings and o-rings for cuts or wear and replace as needed.
9. Turn regulator upside down and remove inlet fitting with o-ring using the same 15/16" wrench. Remove spring and ball. Examine o-ring for cuts or wear and replace as needed. Examine spring for fatigue or breaks and replace as needed.
10. Remove seat with o-ring. Examine o-ring for cuts or wear and replace as needed. Examine seat for nicks or wear and replace as needed.

CAUTION: Exercise extreme caution to avoid contact and damage to the tapered surface of the seat.

Note: With the regulator completely disassembled, inspect sealing area where the seat and piston stem make contact within the internal body of the regulator for grooves, pitting or wear. If damage is found, stop the repair and replace with complete new regulator. If not, proceed with reassembly.

Reassembly

1. Place regulator body with the inlet port facing up.
2. Lubricate and install o-ring onto seat. Press seat with larger tapered hole facing up.
3. Install stainless steel ball onto seat.
4. Lubricate and install o-ring on inlet fitting. Place spring into small hole of inlet fitting. Thread inlet fitting into body of regulator.
5. Turn regulator over with retainer spring port up.
6. Lubricate and install one back-up-ring, one o-ring and second back-up-ring on machined groove of the piston stem.
7. Lubricate and install small o-ring over the piston stem and then place back-up-ring on top of o-ring.
8. Install piston stem with tapered end down into the regulator body.
9. Install piston retainer over piston stem and thread into regulator body. Ensure that hole in the piston stem aligns with slot in the piston retainer.
10. Press in piston pin through slot in piston retainer and hole in piston stem.
11. Apply Loctite® 242® to threads of brass limit nut and thread onto piston stem. Nut should thread down to last thread on piston stem.
12. Install spring over piston stem.
13. Place spring retainer with boss down on spring.
14. Thread on bottom adjusting nut and then top locking nut on piston stem.
15. Re-install regulator onto pump.
16. Reconnect by-pass, discharge and inlet plumbing to regulator.
17. Proceed to PRESSURE ADJUSTMENT.

Loctite® and 242® are registered trademarks of the Henkel Corporation.

TROUBLESHOOTING

Cycling/Chattering	<ul style="list-style-type: none">● Too little flow for valve specifications.● Air in system, poor connections.● Inlet seals in pump worn.● O-ring in gun worn.
System will not build up to pressure	<ul style="list-style-type: none">● Nozzle worn.● Improper nozzle size for system specs.
Pressure drop	<ul style="list-style-type: none">● Nozzles worn.● Piston and seat in regulator worn.● O-ring around piston worn.● Air in system, poor connections.● Insufficient flow to pump.● Filter clogged. Check and clean regularly.
Pressure spikes while in by-pass	<ul style="list-style-type: none">● Minimum by-pass of 5% not present.● Excessive pressure adjustment made for worn nozzle. REPLACE NOZZLE. Reset system pressure.

EXPLODED VIEW

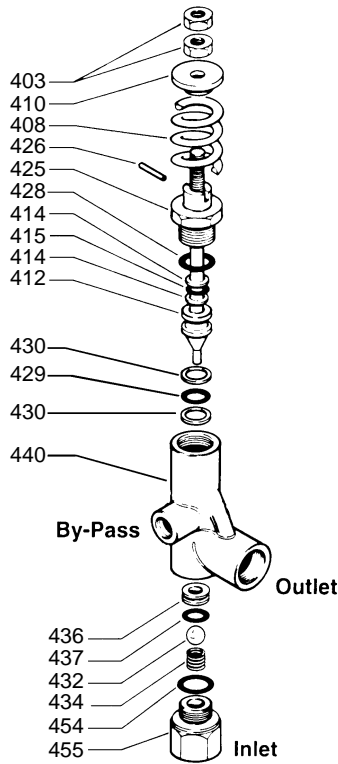

CUTAWAY

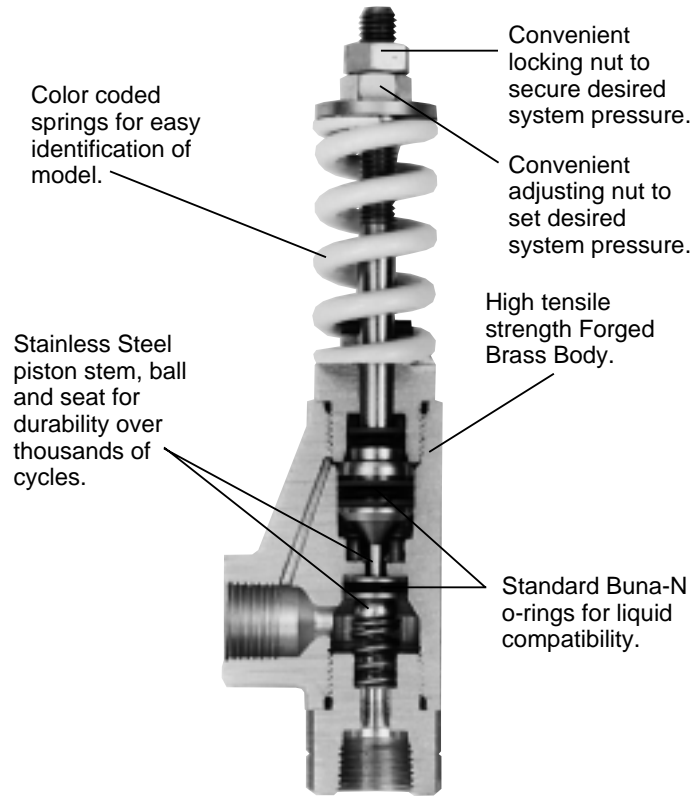

PARTS LIST

ITEM	DESCRIPTION	MODEL NUMBER		QTY
		7080	7082	
403	Nut, Adjusting (M8) <i>Nut, Adjusting (M8)</i>	81109 STZP 126521 STCP R	81109 STZP 126521 STCP R	2 2
408	Spring, White (1450 PSI) Spring, Blue (3450 PSI)	32090 STL	—	1 1
410	Retainer, Spring	— BB	— BB	1 1
412	Stem, Piston	33219 S	33219 S	1
414	Back-up-Ring, Stem	32873 PTFE	32873 PTFE	1
415	O-Ring, Stem	— NBR/FPM	— NBR/FPM	1
425	Retainer, Piston	33318 BB	33318 BB	1
426	Pin, Piston Lock	32818 S	32818 S	1
428	O-Ring, Piston Retainer	— NBR/FPM	— NBR/FPM	1
429	O-Ring, Piston	— NBR/FPM	— NBR/FPM	1
430	Back-up-Ring, Piston	33303 PTFE	33303 PTFE	2
432	Ball	32289 SSSS	32289 SSSS	1
434	Spring	— STZP	— STZP	1
436	Seat, w/O-Ring	— NBR	— NBR	1
437	O-Ring, Seat	— NBR/FPM	— NBR/FPM	1
440	Body	— FBB	— FBB	1
447	<i>Kit, Valve (Incls: 428,432,434,435,436)</i>	33147 NBR	33147 NBR	1
454	O-Ring, Fitting	— NBR/FPM	— NBR/FPM	1
455	Fitting, Inlet (3/8" NPTF)	32111 BB	32111 BB	1
468	<i>Kit, O-Ring (Incls: 414,415,428,429,431,437,439) Prior to 6/88</i>	33146 NBR	33146 NBR	1
—	★ <i>Kit, O-Ring (Incls: 414,415,428,429,431,437,439) After 6/88</i>	33246 NBR	33246 NBR	1
—	★ <i>Kit, O-Ring (Incls: 414,415,428,429,431,437,439) After 6/88</i>	32878 FPM	32878 FPM	1

Italics are optional items. R Components comply with RoHS Directive.

MATERIAL CODES (Not Part of Part Number): BB=Brass FBB=Forged Brass FPM=Fluorocarbon
NBR=Medium Nitrile (Buna-N) PTFE=Pure Polytetrafluoroethylene S=304SS STL=Steel SSSS=440SS STZP=Steel/Zinc Plated
★ Changes effective with unloader marked "2" on body.

Products described hereon are covered by one or more of the following U.S. patents 3558244, 3652188, 3809508, 3920356, 3930756 and 5035580

World Headquarters

CAT PUMPS

1681 - 94th Lane N.E. Minneapolis, MN 55449-4324

Phone (763) 780-5440 — FAX (763) 780-2958

e-mail: techsupport@catpumps.com

www.catpumps.com

International Inquiries

FAX (763) 785-4329

e-mail: intlsales@catpumps.com



The Pumps with Nine Lives

CAT PUMPS (U.K.) LTD.

1 Fleet Business Park, Sandy Lane, Church Crookham

FLEET, Hampshire, GU52 8BF, England

Phone Fleet 44 1252-622031 — Fax 44 1252-626655

e-mail: sales@catpumps.co.uk

N.V. CAT PUMPS INTERNATIONAL S.A.

Heiveldekens 6A, B-2550 Kontich, Belgium

Phone 32-3-450.71.50 — Fax 32-3-450.71.51

e-mail: cpi@catpumps.be www.catpumps.be

CAT PUMPS DEUTSCHLAND GmbH

Buchwiese 2, D-65510 Idstein, Germany

Phone 49 6126-9303 0 — Fax 49 6126-9303 33

e-mail: catpumps@t-online.de www.catpumps.de