

Pressure Sensitive Regulating Unloader

Models

7580
7581

FEATURES

- Provides system pressure setting and protection for single gun non-weep and single pump installation.
- Compact size with optional ports for easy installation.
- Adjusting cap permits easy adjustments of pressure.
- Pressure sensitive feature permits wide range of flows and immediate pressure when gun opens.
- Springs are color coded for easy valve identification and simple change from one pressure rating to another.

SPECIFICATIONS

	U.S. Measure	Metric Measure
MODEL 7580		
Flow Range	0.5-6.5 GPM	(1.9-25 L/M)
Pressure Range	400-1000 PSI	(30-70 BAR)
MODEL 7581		
Flow Range	0.5-6.5 GPM	(1.9-25 L/M)
Pressure Range	800-2300 PSI	(55-158 BAR)

COMMON SPECIFICATIONS

Maximum Temperature.....	160°F	(71°C)
Inlet Port (Back)	3/8" NPTM	(3/8" NPTM)
Outlet Port (Front)	3/8" NPTM	(3/8" NPTM)
By-Pass Port (Bottom)	3/8" NPTF	(3/8" NPTF)
Weight	14 oz.	(0.40 kg)
Dimensions.....	3.0 x 1.0 x 4.25"	(76 x 25 x 108 mm)

Unloader is stamped with a European safety pressure. Use only at above specifications to assure proper unloader life and performance.

For Relief Valve version add .100 to unloader model number.

⚠ WARNING

All systems require both a primary pressure regulating device (i.e., regulator, unloader) and a secondary pressure safety relief device (i.e., pop-off valve, safety valve). Failure to install such relief devices could result in personal injury or damage to the pump or to system components. CAT PUMPS does not assume any liability or responsibility for the operation of a customer's high pressure system.

“Customer confidence is our greatest asset”

SELECTION: This is a pressure sensitive **regulating unloader**. It is designed for systems with a **single pump**, solenoid (gate) valve, nozzle, and standard gun. **“Weep” guns are not recommended with this unloader.**

This unloader holds established system pressure in the discharge line when the trigger gun is closed or solenoid (gate) valve is closed or the nozzle is clogged, by-passing the unrequired flow. It returns to established system pressure without delay upon squeezing the trigger gun or opening the solenoid (gate) valve.

NOTE: For **multiple pump** systems, it is best to use a pressure regulator not an unloader.

Select the specific model of unloader to meet both the desired system flow (combined nozzle flow rate requirement) and the desired system pressure.

Exercise caution when matching the system requirements to the unloader flow capacity and pressure rating. Operation below the minimum flow of the unloader causes the unloader to cycle. Operation beyond the rated unloader flow causes premature valve wear, unloader cycling and prevents attaining desired system pressure.

Select a high pressure nozzle sized to provide for both the desired **system flow** and pressure and **unloader by-pass**.

CAUTION

A MINIMUM BY-PASS FLOW of 5% of the UNLOADER RATED FLOW CAPACITY is required for proper unloader performance.

When properly set this unloader protects the pump from pressure extremes associated with obstructions in the discharge line, while maintaining the established system pressure. When no flow is required by the system, the unloader by-passes all the system flow and relieves the load on the pump. Pressure is held in the discharge line [between the unloader and gun(s) or solenoid valve(s)] ready for a quick return to high pressure operation.

INSTALLATION: This unloader operates properly when mounted in any direction, however, it is preferred to keep the plumbing to a minimum and the adjusting cap easily accessible. The best location is directly on the pump discharge manifold head. Plumbing to and from the unloader should be at least the size of the unloader ports and flexible, high pressure hose (minimum single wire braid) is required.

This is a flow through design unloader. The standard **inlet connection** of this unloader is located at the **back**. The unloader can be mounted directly in the discharge line.

The **by-pass connection** is on the **bottom** of the unloader and can be plumbed in one of the following methods. Note that prolonged by-pass can result in significant heat build-up and frequent by-pass can result in premature wear to the valve. A **MINIMUM BY-PASS OF 5%** is necessary for the unloader to operate properly.

Check the amount of by-pass by disconnecting the by-pass line and measuring the flow into a graduated container.

CAUTION

If the entire output is directed through the unloader (zero by-pass) the “cushioning” feature of the by-pass liquid is eliminated and the unloader can malfunction or wear prematurely.

By-Pass to Reservoir: Ideally the by-pass line should be directed to a reservoir with at least one baffle between the supply line to the pump (from the reservoir) and the return by-pass line (from the unloader into the reservoir). This baffle minimizes turbulence and air bubbles that could enter the pump inlet feed line. **The reservoir capacity should be 6 to 10 times the rated system flow per minute.**

By-Pass to Pump Inlet: Although not recommended, by-pass liquid can be returned to the inlet line of the pump or directly to a pump inlet port. When using this method an *Inlet Pressure Regulator* is recommended to protect the pump inlet (Lo-Pressure Seals) from pressure spikes in the by-pass line. **NOTE:** By-pass line pressure is typically less than 200 PSI. Be certain the *Inlet Pressure Regulator* is **between** the pump inlet and the by-pass line connection. When using this method, a *Thermo Valve* should be installed in the by-pass line to protect the pump from temperature build-up and premature seal failure.

The by-pass line should be **connected to the pump inlet line at a gentle angle of 45° or less and no closer than 10 times the pump inlet port diameter** e.g. 1-1/2" port size = 15" distance from pump inlet port. **Refer to Technical Bulletin 64 for additional information on the size and length of the by-pass line.**

By-Pass to Drain: If the by-pass is limited and infrequent, the by-pass can easily drain to an unpressurized drain line (to the ground).

TYPICAL INSTALLATION

Piston Pump

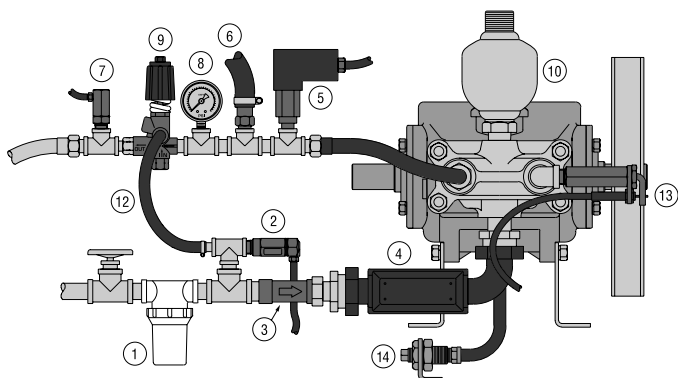

Plunger Pump

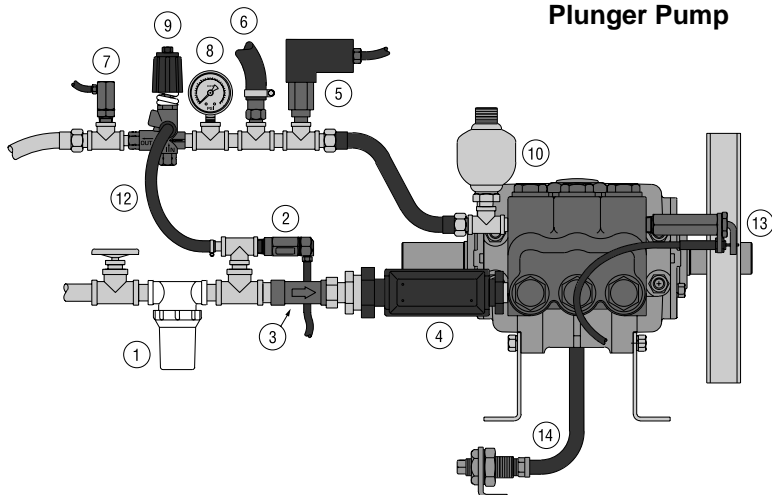

The **outlet connection** is located at the **front** of the unloader with the hex fitting. Plumbing for the spray gun, nozzle or solenoid valve should be connected in line from this discharge port.

It is recommended that a secondary protective device such as the *CAT PUMP Pop-Off Valve* be installed to assure pump protection should the unloader malfunction. Refer to TROUBLESHOOTING for more information on malfunction of unloader.

CAUTION

Oversizing the *Prrrrr-o-lator* may cause delayed response from the unloader.

Preferred mounting of the *Prrrrr-o-lator* (pulsation dampener) is directly **on the Discharge Manifold Head**. When using the Inlet Pressure Regulator, mount the *Prrrrr-o-lator* **downstream from the unloader** to assure optimum performance of the regulator.

PRESSURE ADJUSTMENT AS AN UNLOADER: Setting and adjusting the unloader pressure must be done with the system "on". Start the system with the unloader backed off to the lowest pressure setting (**counterclockwise direction**). Squeeze the trigger and read the pressure on the gauge at the pump. **NOTE: Do not read the pressure at the gun or nozzle.** If more pressure is desired, release the trigger, turn adjusting cap one quarter turn in a **clockwise direction**. Squeeze the trigger and read the pressure. Repeat this process until desired system pressure is attained.

Once the desired system pressure is reached, stop turning the adjusting cap. Thread locking nut up to adjusting cap. **NOTE: The locking nut is not set at the factory.**

If desired system pressure cannot be reached, review TROUBLESHOOTING chart.

When servicing existing systems, back locking nut away from adjusting cap. Follow adjustment procedures as stated above for new unloaders.

NOTE: Do not adjust unloader pressure setting to compensate for a worn nozzle. Check the nozzle as part of the regular maintenance and replace if worn.

PRESSURE ADJUSTMENT AS A RELIEF VALVE: The unloader can also be used as a secondary relief valve by removing the check valve (add .100 when ordering this version). Adjust the pressure of the relief valve in the same increments as the primary valve, then adjust the relief valve to approximately 200 PSI above the primary valve pressure setting.

SERVICE: The unloader should be serviced on the same schedule as your pump. Replacing the O-rings is generally all that is required. Lubricate the O-rings for ease of installation and replace all O-rings included in the kit. Examine the seating surfaces of the seat and ball and valve assembly, piston and replace as needed. Check the adjustment spring and replace as needed. Examine the check valve and replace as needed. Thread the adjusting cap onto the unloader and reset to system pressure.

Approximate Pressure Reading at Gauge	Gauge Between Pump/Unloader	Gauge Between Unloader/Gun-Nozzle-Valve
System in operation (gun open)	system pressure	system pressure
System in by-pass (guns closed)	low pressure 0-150 PSI	system pressure +200 PSI

TROUBLESHOOTING

Unloader cycles	<ul style="list-style-type: none"> ● Worn check valve and o-ring ● Fitting leaking down stream ● O-ring in gun worn
Liquid leaking from bottom of fitting	<ul style="list-style-type: none"> ● O-ring on by-pass fitting or seat cut or worn
Liquid leaking from middle valve retainer	<ul style="list-style-type: none"> ● O-ring for valve retainer worn or cut ● O-rings from valve stem worn or cut
Unloader will not come up to pressure	<ul style="list-style-type: none"> ● Unloader not properly sized for system pressure ● Foreign material in unloader ● Valve stem o-rings worn. ● Nozzle worn
Extreme pressure spikes	<ul style="list-style-type: none"> ● Adjusting cap turned completely into unloader ● Restricted by-pass — must be at least port size, preferably one size larger ● O-rings on valve stem worn ● System flow exceeds unloader rating

WARRANTY

90 Day Warranty

Refer to complete CAT PUMPS Warranty for further information.

- | | |
|---|----------------------------------|
| 1 Inlet Filter | 8 Pressure Gauge |
| 2 Thermo Valve | 9 Pressure Regulator/Unloader |
| 3 Inlet Pressure Regulator | 10 Pulsation Dampener★ |
| 4 C. A.T. Tube
(Captive Acceleration Tube) | 11 Chemical Injector (Not Shown) |
| 5 Pressure Switch | 12 By-pass Hose |
| 6 Pop-Off Valve | 13 Throttle Controller |
| 7 Quick Start Valve | 14 Oil Drain Kit |

★ Preferred mounting of Pulsation Dampener [Prrrrr-O-Lator] is directly on the discharge manifold of the pump. The preferred mounting of the by-pass hose [when returning to the inlet] is before the Pressure Reducing Valve. If this is not possible, then mount the Prrrrr-O-Lator after the Pressure Unloading Valve to prevent pressure spikes to the pump inlet.

These illustrations show the basic elements for a typical installation of a high pressure piston or plunger pump. **Not all components shown are required for all applications or systems.** Each component presents potential problems that too often are ascribed to a perfectly functioning pump, such as: a clogged strainer, a partially closed shut-off valve, a faulty gauge, or a malfunctioning regulator/unloader. Proper system installation, routine lubrication, monitoring and maintenance of components are your basic guarantees of optimum pump performance. CAT PUMPS does not assume any liability or responsibility for the design or operation of a customer's high pressure system.

EXPLODED VIEW

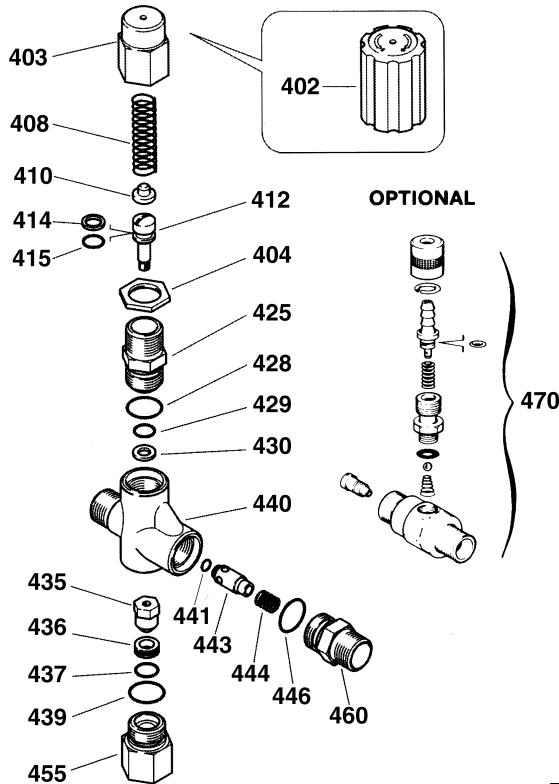

CUTAWAY

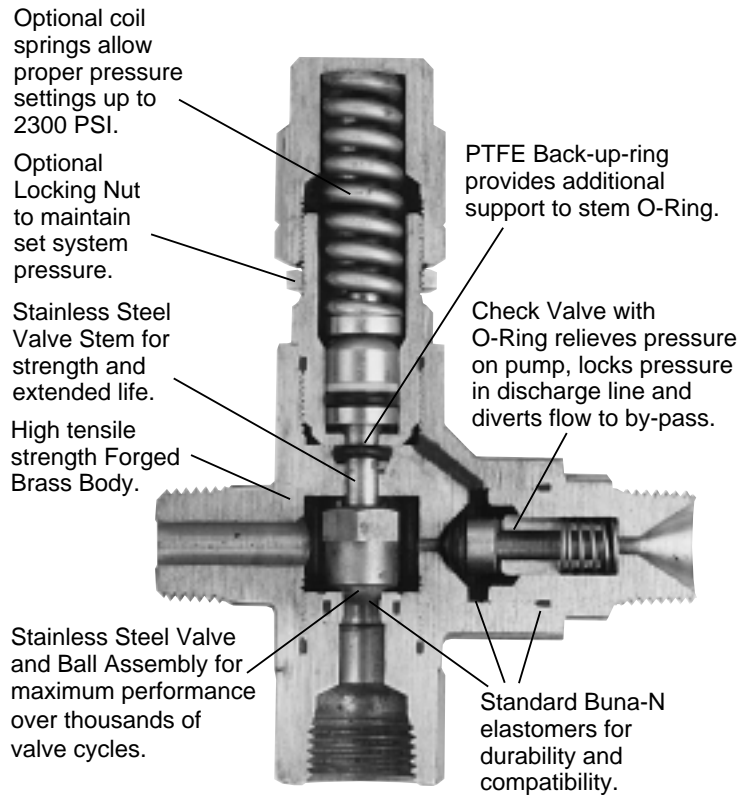

PARTS LIST

ITEM	DESCRIPTION	MODEL NUMBER				QTY
		7580	MATL	7581	MATL	
402	Cap, Black	32088	NY	32088	NY	1
403	Cap, Hex Adjusting	33859	BB	33859	BB	1
404	Nut, Lock	31047	BB	31047	BB	1
408	Spring - Gold - 1000 PSI	32093	STZP	—	—	1
	Spring - Silver - 2000 PSI	—	—	32094	STZP	1
410	Retainer, Spring	32819	STZP	32819	STZP	1
412	Stem, Valve (M5)	33118	S	33118	S	1
414	Back-up-Ring	—	PTFE	—	PTFE	1
415	O-Ring, Stem	—	NBR	—	NBR	1
425	Retainer, Valve	39002	BB	39002	BB	1
428	O-Ring, Valve Retainer	—	NBR	—	NBR	1
429	O-Ring	—	NBR	—	NBR	1
430	Back-up-Ring	—	PTFE	—	PTFE	1
435	Valve and Ball Assembly (M5)	34157	S	34157	S	1
436	Seat w/O-Ring	31853	NBR	31853	NBR	1
437	O-Ring, Seat	—	NBR	—	NBR	1
439	O-Ring, By-Pass Fitting	—	NBR	—	NBR	1
440	Body	—	FBB	—	FBB	1
441	O-Ring, Check Valve	—	NBR	—	NBR	1
443	Valve, Check	33158	BB	33158	BB	1
444	Spring	39065	S	39065	S	1
446	O-Ring, Discharge Fitting	—	NBR	—	NBR	1
455	Fitting, By-pass (3/8" NPTF)	32123	BB	32123	BB	1
460	Fitting, Discharge (3/8" NPTM)	32122	BB	32122	BB	1
468	Kit, O-Ring (Incls: 414, 415, 428, 429, 430, 437, 439, 441, 446)	33156	NBR	33156	NBR	1
470	Adjustable Chemical Injector (See Indiv. Date Sheet for Selection)	7192-94	—	7192-94	—	1

Italics are optional items.

MATERIAL CODES (Not Part of Part Number): BB=Brass FBB=Forged Brass NBR=Medium Nitrile (Buna-N)

NY=Nylon PTFE=Pure Polytetrafluoroethylene S=304SS STZP=Steel/Zinc Plated

See Chemical Injector for optional Unloader mount Models

Note: To mount injector on unloader, remove items 460, 446, 444, 443 and 441. Insert 444, 443, and 441 into injector (470). Thread injector (470) into unloader. Discard fitting (460) and o-ring (446). See Adjustable Chemical Injector Data sheet for additional data and service parts for injector.

Products described hereon are covered by one or more of the following U.S. patents 3558244, 3652188, 3809508, 3920356, 3930756 and 5035580

World Headquarters

CAT PUMPS

1681 - 94th Lane N.E. Minneapolis, MN 55449-4324

Phone (763) 780-5440 — FAX (763) 780-2958

e-mail: techsupport@catpumps.com

www.catpumps.com

International Inquiries

FAX (763) 785-4329

e-mail: intl@catpumps.com



The Pumps with Nine Lives

CAT PUMPS (U.K.) LTD.

1 Fleet Business Park, Sandy Lane, Church Crookham

FLEET, Hampshire, GU52 8BF, England

Phone Fleet 44 1252-622031 — Fax 44 1252-626655

e-mail: sales@catpumps.co.uk

N.V. CAT PUMPS INTERNATIONAL S.A.

Heiveldekens 6A, B-2550 Kontich, Belgium

Phone 32-3-450.71.50 — Fax 32-3-450.71.51

e-mail: cpi@catpumps.be www.catpumps.be

CAT PUMPS DEUTSCHLAND GmbH

Buchwiese 2, D-65510 Idstein, Germany

Phone 49 6126-9303 0 — Fax 49 6126-9303 33

e-mail: catpumps@t-online.de www.catpumps.de