



TECH BULLETIN

053
11/88

Published regarding engineering changes and improvements

SUBJECT: Liquid Gasket - Plunger Pump Models

For aggressive liquid applications such as car wash, reverse osmosis, leachate, and saltwater re-injection.

To enhance the life of pumps used with aggressive liquids, Liquid Gasket should be applied to certain mating surfaces during maintenance. The application of the Liquid Gasket in o-ring and seal crevices and metal mating surfaces provides an environment in which the part can flex without inducing an erosion-corrosion cycle on the adjacent metal. By filling the gaps between mating surfaces, there is no stagnant fluid that can cause crevice corrosion. Filled gaps are also less prone to harbor bacteria.

The following instructions cover the procedures for applying Liquid Gasket to specific parts and surfaces when servicing. All surfaces should be wiped clean before applying any Liquid Gasket. On mating surfaces **only a thin film is required**. Avoid using excess material. Around o-rings and seals liquid gasket should be applied in sufficient quantity to ensure that the crevices are filled on the side exposed to the pumped fluid. Please read **Material Safety Data** information before application.

Excess Liquid Gasket should be wiped away as assembly proceeds. **NOTE: Flush pump and drain approximately 5 minutes prior to connecting to operating system.** Refer to individual pump service manuals for proper assembly procedure and torque requirements. Please order PN 6104 Liquid Gasket in addition to seal and valve kits for servicing.

NOTE: Liquid Gasket is applied to all specified surfaces in all Stainless Steel and Nickel Aluminum Bronze pump models during production.

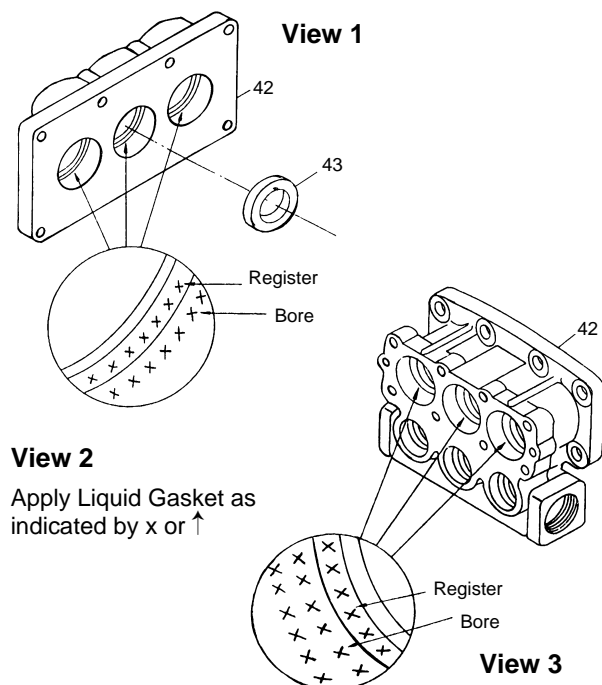

LO-PRESSURE SEAL (View 1)

Before fitting Lo-pressure seal into inlet manifold, apply Liquid Gasket in the manifold bores where the seals will make contact with the manifold chamber walls. Remove EXCESS Liquid Gasket.

HI-PRESSURE SEAL (View 2)

Apply Liquid Gasket in the manifold chamber walls where the Hi-pressure seal will make contact when installed. See individual pump service manual for correct seal installation procedure. Remove EXCESS Liquid Gasket.

MALE AND FEMALE ADAPTERS (View 3)

Apply Liquid Gasket to the 'V' of the Female Adapter and to the manifold chamber or V-Packing Cylinder where the V-Packings will make contact. Apply Liquid Gasket to the 'V' of the Male Adapter and to the manifold chamber walls where the male adapter comes in contact. Remove EXCESS Liquid Gasket.

Continued on other side...

Rev. 06/04

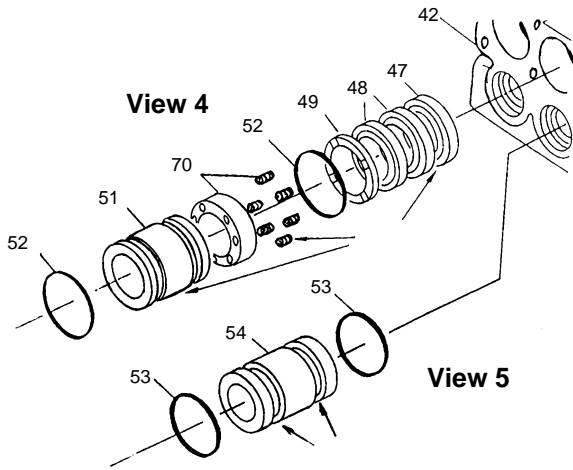

Apply Liquid Gasket as indicated ↑

V-PACKING CYLINDER AND SPACER W/COIL SPRINGS (View 4)

Fill the spring cavities of the 35FR and 60FR models (3x6-35FR) (3x8-60FR) with Liquid Gasket. Apply Liquid Gasket to back of Spacer. Remove EXCESS Liquid Gasket.

Fit o-rings onto V-Packing Cylinder grooves and generously fill crevices with Liquid Gasket. Remove EXCESS Liquid Gasket.

INLET SPACER (View 5)

(Exclusive to Model 6767) Fit o-rings onto Spacer and fill crevices with Liquid Gasket. Apply Liquid Gasket to the Inlet Manifold chamber walls and install the Spacers.

(Other Models) Apply Liquid Gasket to o-ring groove of Inlet Manifold and insert o-ring. Remove EXCESS Liquid Gasket.

DISCHARGE MANIFOLD (View 6)

Apply Liquid Gasket to the manifold chambers before installing V-Packing Cylinders in the manifold or Discharge Valve Spacers (25FR) in manifold over Spacers.

Remove EXCESS Liquid Gasket.

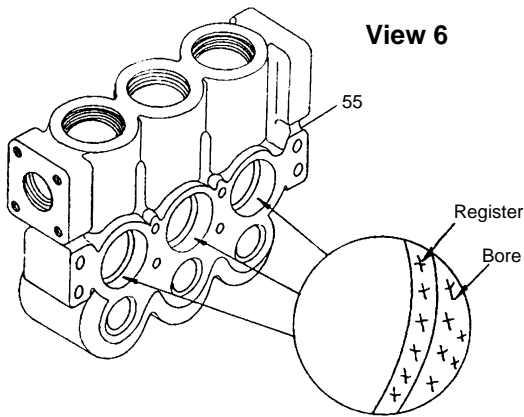

Apply Liquid Gasket as indicated by x or ↑

VALVE SEATS (View 7)

Assemble the valve assemblies and then fit o-rings and back-up rings onto valve seats. Fill the crevices with Liquid Gasket.

Apply Liquid Gasket to the discharge manifold chambers where the valve seat rests. Remove EXCESS Liquid Gasket.

VALVE PLUGS (View 8)

Fit o-rings into valve plugs and fill o-ring crevices with Liquid Gasket. Remove EXCESS Liquid Gasket.

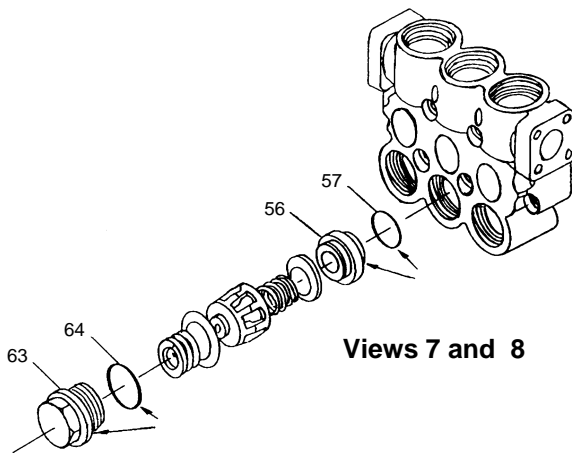

Apply Liquid Gasket as indicated by ↑

PN 6104

MATERIAL SAFETY DATA

5/13/03

Hazardous Ingredients	Silica Amorphous 10-20%, Polyester Polyol 80-90%
Boiling Point	Not Available
Vapor Pressure	Not Available
Vapor Density	Not Available
Solubility in Water.....	Insoluble
Appearance and Odor.....	Blue gel, mild odor
Specific Gravity	1.18
Evaporation Rate.....	Not Available
Flash Point	400°F
Extinguishing Media	Foam Carbon Dioxide Dry Chemical
Health Hazard	
Eye	YES Severe eye irritation
Inhalation.....	YES (Solvent) Dizziness and shortness of breath
Skin	POSSIBLE (Solvent) Redness and prolonged contact may cause irritation
Ingestion.....	POSSIBLE
Reactivity.....	Residual putty not believed to be toxic Stable, hazardous polymerization will not occur, incompatible with strong oxidizers or acids
Emergency & First Aid Procedures:	
	EYES: Flush with water for at least 15 minutes, seek medical aid.
	SKIN: Wash with warm soapy water. Remove contaminated clothing.
	INHALATION: Rest and fresh air, seek medical aid.
	INGESTION: Do not induce vomiting, seek medical aid.

This information highlights the proper use in handling of this product under normal conditions. Normal caution should be exercised when using.

CAT PUMPS

Technical Services Department