

DATA SHEET

HIGH FLOW REGULATING UNLOADER



Brass Model: 9950



FEATURES

- Maintains full system pressure while running in by-pass without full load on pump.
- Offers pump protection against pressure fluctuations and system changes.
- Easy external pressure adjustment with locking nut to prevent pump over pressure.
- Flow through design for convenient in-line mounting.
- Optional remote mounting feature.

SPECIFICATIONS

	U.S. Measure	Metric Measure
Flow Range	50-120 gpm	189-450 lpm
Pressure Range	100-2900 psi	6.9-200 bar
Maximum Temperature	140°F	60°C
Inlet Port (Back)	1-1/4" BSP(F)	1-1/4" BSP(F)
Discharge Port (Front)	1-1/4" BSP(F)	1-1/4" BSP(F)
By-Pass Port (Bottom)	1-1/2" BSP(F)	1-1/2" BSP(F)
Weight	13.12 lbs.	5.95 kg
Dimensions	12.51 x 6.66 x 2.50"	318 x 169.5 x 63.5 mm

Use only at above specifications to assure unloader life and performance.
For relief valve add .100 to unloader model number.

Read all CAUTIONS and WARNINGS before commencing service or operation of any high-pressure system.

SELECTION

This is a pressure sensitive regulating unloader. Designed for systems with single or multiple pumps, solenoid (gate) valves, nozzles, standard or "weep" guns.

Note: For multiple pump systems, it is best to use a pressure regulator not a pressure sensitive regulating unloader.

This pressure sensitive regulating unloader should meet both the desired system flow (combined nozzle flow rate requirement) and the desired system pressure.

Note: Operation below the minimum flow of the unloader causes the unloader to cycle. Operation above the maximum flows of the unloader causes premature unloader wear, cycling and prevents attaining desired system pressure.

INSTALLATION

This unloader operates properly when mounted in any direction, however, it is preferred to keep the plumbing to a minimum and the pressure adjuster handle easily accessible. The best mounting location is directly on the pump discharge manifold head.

The inlet connection on this unloader is a 1-1/4" BSP(F) sized port and is located on the back side. There is an arrow and the word IN cast into the body indicating the direction of flow. Fluid from the discharge of the manifold goes through this connection.

The discharge connection on this unloader is a 1-1/4" BSP(F) sized port and is located on the front side (hex end). There is an arrow and the word OUT cast into the body indicating the direction of flow. Plumbing for the spray guns, solenoid (gate) valves or nozzles are connected here.

The by-pass connection of this unloader is a 1-1/2" BSP(F) sized port and is located on the bottom. There is an arrow and the word BY-PASS cast into the body indicating the direction of flow. By-Pass fluid is directed out of this port and can be routed to a reservoir (preferred method), or to a drain or to the pump inlet.

OPERATION

This pressure sensitive regulating unloader holds established system pressure in the discharge line when the trigger gun is closed or solenoid (gate) valve is closed or the nozzle is clogged, thus by-passing all unrequired flow. Squeezing the trigger gun or opening the solenoid (gate) valve will close off the by-pass and return to established system pressure without delay.

PRESSURE ADJUSTMENT

Pressure Adjustment as an Unloader

1. Setting and adjusting the unloader pressure must be done with the system "on".
2. Start the system with unloader backed off to the lowest pressure setting (counterclockwise direction).
3. Squeeze the trigger and read the pressure on the gauge at the pump.
Note: Do not read the pressure at the gun or nozzle.
4. If more pressure is desired, release the trigger, turn pressure adjuster one quarter turn in clockwise direction.
5. Squeeze the trigger and read the pressure.
6. Repeat this process until desired system pressure is attained.
7. Once the desired system pressure is reached, stop turning the pressure adjuster.
8. Thread locking nut up to pressure adjuster.

Note: Locking nut is not set at the factory.

Notice: A minimum by-pass flow of 5% of the unloader rated flow capacity is required for proper unloader performance. If the entire output is directed through the unloader (zero by-pass) the "cushioning" feature of the by-pass liquid is eliminated and the unloader can malfunction or wear prematurely.

9. If desired system pressure cannot be reached, review TROUBLESHOOTING chart.
10. When servicing existing systems, back locking nut away from pressure adjuster.
11. Follow adjustment procedures as stated above for new unloaders.

Note: Do not adjust unloader pressure setting to compensate for a worn nozzle. Check the nozzle as part of the regular maintenance and replace if worn.

Pressure Adjustment as a Relief Valve

1. Remove hex discharge fitting, spring and check valve from discharge port.
2. Reinstall hex discharge fitting into discharge port.
3. Turn pressure adjuster on the top of the relief valve in a counterclockwise direction in small increments until there is some visible fluid coming out of the by-pass port.
4. Turn pressure adjuster in a clockwise direction until visible fluid stops coming out.
5. Final adjustment for the relief valve should relieve at 200 PSI above the operating system.

TYPICAL UNLOADER INSTALLATION

- 1 Pressure Gauge
- 2 Relief Valve
Show as a secondary safety relief valve
- 3 Pulsation Dampener
- 4 Pressure Sensitive Regulating Unloader
- 5 Triplex Plunger Pump with Rails
- 6 Inlet Stabilizer Not Shown
Recommended for Industrial Applications

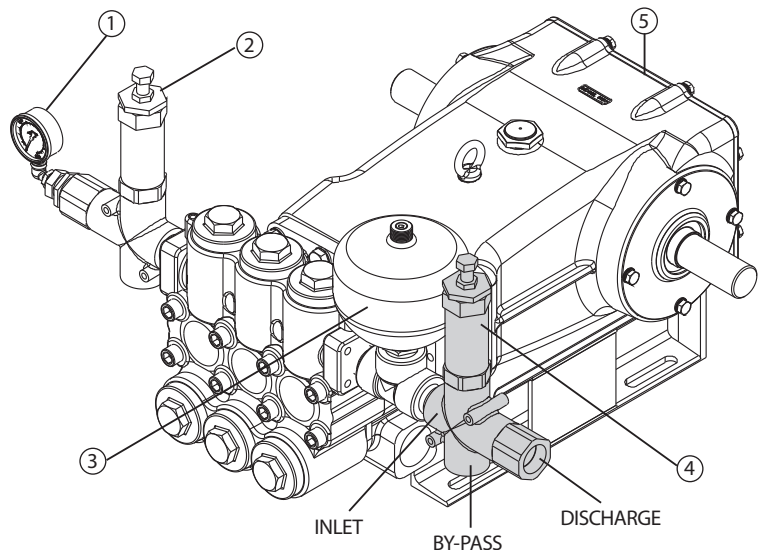

Read all CAUTIONS and WARNINGS before commencing service or operation of any high-pressure system.

SERVICING

Disassembly

1. Disconnect by-pass and discharge plumbing from unloader.
2. Remove unloader from pump.
3. Secure unloader in a vise. Use a wrench to remove brass spring retainer.
4. Remove upper spring retainer and springs from upper body. Examine springs for fatigue or breaks and replace as needed.
5. Using the same wrench, unthread upper body from lower body. Remove upper body and lower spring retainer.
6. Remove piston stem and valve assembly which includes the upper and lower piston retainers from lower body. Seat will remain in lower body.
7. Secure valve with pliers on flat surfaces and then place a M10 allen wrench into hex head of piston stem. Remove valve from piston stem.

CAUTION: Exercise extreme caution to avoid contact and damage to the tapered surface of the valve.

8. Place piston stem with hex hole down on work surface.
9. Remove lower piston retainer with o-rings and back-up-ring. Examine outside diameter o-ring and inside diameter o-ring with back-up-ring for cuts or wear and replace as needed.
10. Remove upper piston retainer with o-rings and back-up-ring. Examine outside diameter o-ring and inside diameter o-ring with back-up-ring for cuts or wear and replace as needed.
11. Examine large and small outside diameter surfaces of the piston stem for scratches or nicks and replace as needed.
12. Examine seat in lower body for scoring or wear and replace as needed.
13. Remove discharge fitting with o-ring, spring, check valve and o-ring. Examine check valve and spring for fatigue and wear and replace as needed. Examine o-rings for cuts or wear and replace as needed.

Note: While the discharge fitting is removed, inspect sealing area where the check valve makes contact within the internal body of the unloader for grooves, pitting and wear. If damage is found, stop the repair and replace with complete new unloader. If not, proceed with reassembly.

Reassembly

1. Place spring inside check valve. Lubricate and install o-ring on outside diameter of check valve. Install check valve assembly into discharge port of lower body of unloader.
2. Apply Loctite® 242® to threads of discharge fitting. Thread discharge fitting into body of unloader.
3. Lubricate and install o-ring onto seat. Press seat into unloader lower body.
4. Place piston stem with hex hole down on work surface.
5. Lubricate and install small o-ring inside upper piston retainer, then place back-up-ring on top of o-ring. Lubricate and install larger o-ring around the outside diameter of upper piston retainer.
6. Place upper piston retainer with back-up-ring facing downwards over piston stem.
7. Install back-up-ring inside lower piston retainer, then lubricate and install o-ring on top of back-up-ring. Lubricate and install larger o-ring around outside diameter of lower piston retainer.
8. Place lower piston retainer with o-ring facing down over piston stem and press against the upper piston retainer.
9. Apply Loctite® 242® to threads of piston stem and screw valve onto piston stem.
10. Lower complete piston stem and valve assembly into unloader chamber with valve facing down and hex head of piston stem facing up. Press until piston stem head is below lower body surface.
11. Thread upper body into lower body.
12. Place lower spring retainer with stainless steel ball down and small diameter guide facing up into the upper body.
13. Install springs onto lower spring retainer.
14. Place upper spring retainer on top of spring with small diameter guide facing down.
15. Thread on spring retainer to upper body. Do not tighten pressure adjuster at this time.
16. Re-install unloader onto pump.
17. Reconnect by-pass and discharge plumbing to unloader.
18. To set system pressure as an unloader or relief valve see PRESSURE ADJUSTMENT.

Loctite® 242® are registered trademarks of the Henkel Corporation.

TROUBLESHOOTING

Unloader cycles	<ul style="list-style-type: none"> • Worn O-ring or check valve • Fitting leaking downstream • O-ring in gun worn • Insufficient flow through unloader
Liquid leaking from bottom	<ul style="list-style-type: none"> • O-ring for seat or inlet fitting cut or worn
Liquid leaking from middle	<ul style="list-style-type: none"> • O-ring for piston worn or cut
Unloader will not come up to pressure	<ul style="list-style-type: none"> • Not properly sized for system pressure • Foreign material in unloader • Piston o-rings worn • Nozzle worn or too large • Jam nuts not properly set
Extreme pressure spikes	<ul style="list-style-type: none"> • Adjusting handle turned completely into unloader • Restricted by-pass or no by-pass • System flow exceeds unloader rating

PRESSURE READING

Approximate Pressure Reading at Gauge	Gauge Between Pump/Unloader	Gauge Between Unloader/Gun-Nozzle-Valve
System in Operation (Gun Open)	System Pressure	System Pressure
System in By-Pass (all guns, valves closed)	Low Pressure 0 - 150 psi	System Pressure +200 psi

EXPLODED VIEW

PARTS LIST

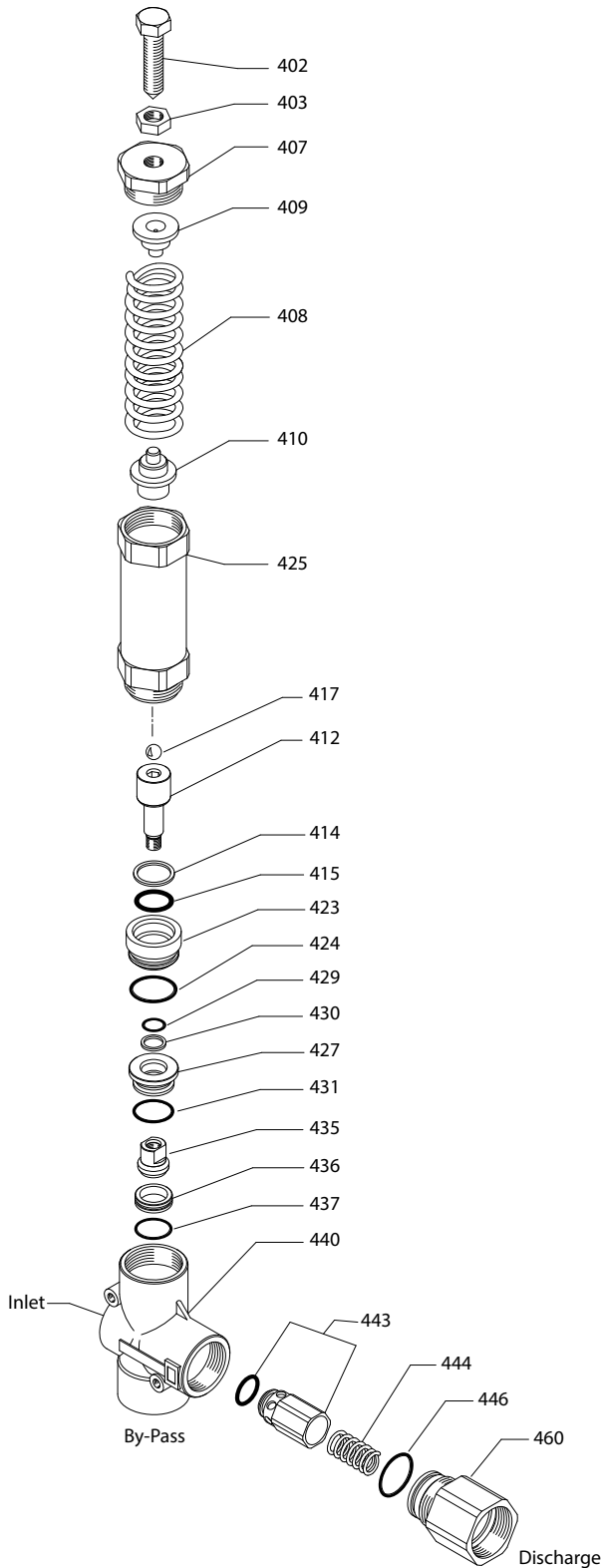

ITEM	P/N	MATL	DESCRIPTION	QTY
402	—	S	Adjuster, Pressure (M16x54)	1
403	—	S	Nut, Hex Locking (M16)	1
407	—	BB	Retainer, Spring	1
408	76220	STL R	Spring	1
409	—	BB	Retainer, Spring, Upper	1
410	—	BB	Retainer, Spring, Lower	1
412	76425	S	Stem, Piston	1
414	—	PTFE	Back-up-Ring, Piston Stem	1
415	—	NBR	O-Ring, Piston Stem	1
417	76550	SSS	Ball	1
423	—	BB	Retainer, Upper Piston	1
424	—	NBR	O-Ring, Upper Piston Retainer - 85D	1
425	—	BB	Body, Upper	1
427	—	BB	Retainer, Lower Piston	1
429	—	NBR	O-Ring, Piston Stem	1
430	—	PTFE	Back-up-Ring, Piston Stem	1
431	—	NBR	O-Ring, Lower Piston Retainer - 85D	1
435	76190	SSS	Valve	1
436	76455	SSS	Seat	1
437	—	NBR	O-Ring, Seat - 85D	1
440	—	BB	Body, Lower	1
443	76311	BB	Valve, Check w/O-Ring	1
444	76230	SS	Spring, Check Valve	1
446	—	NBR	O-Ring, Discharge Fitting - 85D	1
460	—	BB	Fitting, Discharge [1-1/4" BSP(F)]	1
468	31889	NBR	Kit, O-Ring	1

(Incls: 414,415,424,429,430,431,437,446)

Italics are optional items.
 R Components comply with RoHS Directive.
 MATERIAL CODES (Not Part of Part Number):
 BB=Brass NBR=Medium Nitrile (Buna-N) S=304SS SS=316SS
 SSS=416SS STL=Steel PTFE=Polytetrafluoroethylene

⚠ CAUTIONS AND WARNINGS

All High Pressure Systems require a primary pressure regulating device (i.e. regulator, unloader) and a secondary pressure relief device (i.e. pop-off valve, relief valve). Failure to install such relief devices could result in personal injury or damage to pump or property. Cat Pumps does not assume any liability or responsibility for the operation of a customer's high pressure system.

Read all CAUTIONS and WARNINGS before commencing service or operation of any high pressure system. The CAUTIONS and WARNINGS are included in each service manual and with each Accessory Data sheet. CAUTIONS and WARNINGS can also be viewed online at www.catpumps.com/cautions-warnings or can be requested directly from Cat Pumps.

WARRANTY

View the Limited Warranty on-line at www.catpumps.com/warranty.