

DATA SHEET

5CP PLUNGER PUMPS



The Pumps with Nine Lives

**Stainless Steel
Models:**

**5CPQ6221, 5CPQ6241CS, 5CPQ6251
5CPQ6261CSS, 5CPQ6271CSS**

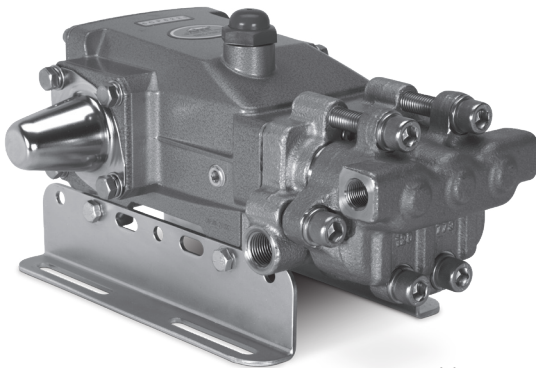

Model 5CPQ6221 Shown
(Rails and shaft protector sold separately)

FEATURES

- 316 Stainless Steel wet end.
- Various Drive configurations including direct drive bell housing to electric motor, belt drive to engine or motor, and direct drive to hydraulic motor.
- "Q" feature is designed for application where a reduced sound level is desirable.
- Standard NBR seals with alternative options for temperature and chemical compatibility.
 - FPM – .0110
 - EPDM – .0220

COMMON SPECIFICATIONS

	U.S.	Metric
Pump RPM* (Model 5CPQ6221)	1400 rpm	1400 rpm
Pump RPM*	1725 rpm	1725 rpm
Inlet Pres. Range (Model 5CPQ6221)	-5 – 60 psi	-0.35 – 4.1 bar
Inlet Pressure Range	Flooded to 60 psi	Flooded to 4.1 bar
Max. Liquid Temperature	160°F	71°C
Above 130°F call Cat Pumps for inlet conditions and elastomer recommendations.		
Bore	0.787"	20 mm
Crankcase Capacity	17 oz.	0.53 l
Inlet Ports (2)	1/2" NPT(F)	1/2" NPT(F)
Discharge Ports (2)	3/8" NPT(F)	3/8" NPT(F)
Shaft Diameter	0.787"	20 mm
Weight	20 lbs.	8 kg
Dimensions	11.47 x 10.0 x 5.75"	291.3 x 254 x 146

*Pump minimum is 100 RPM.

SPECIFICATIONS

	U.S. Measure	Metric Measure
5CPQ6221		
Flow	6.0 gpm	23 lpm
Pressure Range	100 – 2000 psi	6.9 – 138 bar
Stroke	0.709"	18 mm
5CPQ6221 ALTERNATE SPECIFICATIONS		
Flow	7.4 gpm	28 lpm
Pressure Range	100 – 1200 psi	6.9 – 83 bar
Stroke	0.709"	18 mm
5CPQ6241CS		
Flow	4.0 gpm	15 lpm
Pressure Range	100 – 2000 psi	6.9 – 138 bar
Stroke	0.394"	10 mm
5CPQ6251		
Flow	5.0 gpm	19 lpm
Pressure Range	100 – 2000 psi	6.9 – 138 bar
Stroke	0.472"	12 mm
5CPQ6261CSS		
Flow	5.5 gpm	21 lpm
Pressure Range	100 – 2000 psi	6.9 – 138 bar
Stroke	0.557"	14 mm
5CPQ6271CSS		
Flow	6.6 gpm	25 lpm
Pressure Range	100 – 1800 psi	6.9 – 124 bar
Stroke	0.650"	16.5 mm

ELECTRIC HORSEPOWER REQUIREMENTS

MODELS	FLOW		PRESSURE			RPM
			psi 1200	psi 1800	psi 2000	
	gpm	lpm	bar 83	bar 124	bar 138	
5CPQ6221	6.0	23	4.9	7.4	8.2	1400
5CPQ6221 ALTERNATE	7.4	28	6.1	NA	NA	1725
5CPQ6241CS	4.0	15	3.3	4.9	5.5	1725
5CPQ6251	5.0	19	4.1	6.2	6.8	1725
5CPQ6261CSS	5.5	21	4.5	6.8	7.5	1725
5CPQ6271CSS	6.6	25	5.4	8.1	NA	1725

**DETERMINING
THE PUMP R.P.M.**

$$\frac{\text{Rated gpm}}{\text{Rated rpm}} = \frac{\text{"Desired" gpm}}{\text{"Desired" rpm}}$$

**DETERMINING
THE REQUIRED H.P.**

$$\text{Hp (Electric Brake)} = \frac{\text{gpm} \times \text{psi}}{1460}$$

**DETERMINING
MOTOR PULLEY SIZE**

$$\frac{\text{Motor Pulley O.D.}}{\text{Pump rpm}} = \frac{\text{Pump Pulley O.D.}}{\text{Motor rpm}}$$

See complete Drive Packages [Includes: pulleys, belts, hubs, key] Tech Bulletin 003.
Refer to pump **Service Manual** for repair procedure and additional technical information.

PARTS LIST

ITEM	PART NUMBER	MATL	DESCRIPTION	QTY
2	30057	STL	Key (M6x6x25)	1
5	119049	SS	Screw, HHC, Sems (M8x16)	8
8	46910	AL	Cover, Bearing (Models 5CPQ6221, 5CPQ6251)	2
	46910	AL	Cover, Bearing (Models 5CPQ6241CS, 5CPQ6261CSS, 5CPQ6271CSS)	1
10	14028	NBR	O-Ring, Bearing Cover - 70D (Models 5CPQ6221, 5CPQ6251)	2
	14028	NBR	O-Ring, Bearing Cover - 70D (Models 5CPQ6241CS, 5CPQ6261CSS, 5CPQ6271CSS)	1
11	43222	NBR	Seal, Oil, Crankshaft - 70D	2
15	127472	STL	Bearing, Ball	2
20	48742	TNM	Rod Assy, Connecting [10/01]	3
25	46928	FCM	Crankshaft, Dual End (M18) (Model 5CPQ6221)	1
	48203	FCM	Crankshaft, Single End (M10) (Model 5CPQ6241CS)	1
	46982	FCM	Crankshaft, Dual End (M12) (Model 5CPQ6251)	1
	49872	FCM	Crankshaft, Single End (M14) (Model 5CPQ6261CSS)	1
	48368	FCM	Crankshaft, Single End (M16.5) (Model 5CPQ6271CSS)	1
30	48224	AL	Cover, Blind Bearing (Model 5CPQ6241CS)	1
	49776	AL	Cover, Blind Bearing (Models 5CPQ6261CSS, 5CPQ6271CSS)	1
31	127409	—	Cap, Vented w/ O-Ring (Rain Cap)	1
32	46798	—	Cap, Oil Filler	1
33	14179	NBR	O-Ring, Oil Filler Cap - 70D	1
37	92241	—	Gauge, Oil, Bubble w/Gasket - 80D	1 or 2
38	44428	NBR	Gasket, Flat, Oil Gauge - 80D	1 or 2
40	92538	S	Screw, HHC, Sems (M6x16)	4
48	25625	STCP	Plug, Drain (1/4X19BSP)	1
49	23170	NBR	O-Ring, Drain Plug - 70D	1
50	46940	AL	Cover, Rear	1
51	14044	NBR	O-Ring, Cover, Rear	1
53	48617	AL	Crankcase	1
64	46746	CM	Pin, Crosshead	3
65	48458	BBNP	Rod, Plunger	3
70	46838	NBR	Seal, Oil, Crankcase - 70D	3
71	48208	PVDF	Washer, Oil Seal	3
75	43328	S	Slinger, Barrier	3
88	45697	S	Washer, Keyhole (M18x10)	3
90	46841	CC	Plunger (M20x50)	3
98	46730	NBR	Washer, Seal - 90D	3
	48394	FPM	Washer, Seal - 90D	3
	◆ 48432	EPDM	Washer, Seal	3
99	† 48201	SS	Retainer, Plunger (M6x30)	3
100	46749	PVDF	Retainer, Seal	3
106	132277	NBR	Seal, LPS	3
	45153	FPM	Seal, LPS w/SS-Spg	3
	◆ 48429	EPDM	Seal, LPS w/SS-Spg, 2-Pc w/S Support	3
110	48552	SS	Manifold, Inlet	1
117	119034	S	Screw, HSH (M8x35)	4
125	833824	SNG	Seal, HPS	3
	44936	FPM	Seal, HPS w/SS	3
	46667	HT	Seal, HPS w/S	3
143	17615	NBR	O-Ring, I.V. Adapter, Rear - 75D	3
	15855	FPM	O-Ring, I.V. Adapter, Rear - 70D	3
	◆ 48431	EPDM	O-Ring, I.V. Adapter, Rear - 75D	3
150	48212	SS	Adapter, Inlet	3
154	43781	NBR	O-Ring, I.V. Adapter, Front - 75D	3
	11337	FPM	O-Ring, I.V. Adapter, Front - 75D	3
	◆ 48430	EPDM	O-Ring, I.V. Adapter, Front - 75D	3
155	43781	NBR	O-Ring, D.V. Adater, Rear - 75D	3
	11337	FPM	O-Ring, I.V. Adapter, Front - 75D	3
	◆ 48430	EPDM	O-Ring, I.V. Adapter, Front - 75D	3
157	48211	SS	Adapter, Discharge	3
159	43781	NBR	O-Ring, D.V. Adapter, Front - 75D	3
	11337	FPM	O-Ring, I.V. Adapter, Front - 75D	3
	◆ 48430	EPDM	O-Ring, I.V. Adapter, Front - 75D	3
163	43781	NBR	O-Ring, Seat - 75D	3
	11337	FPM	O-Ring, Seat - 75D	3
	◆ 48430	EPDM	O-Ring, Seat - 75D	3
164	48216	SS	Seat	6
165	43793	NBR	O-Ring, Seat - 90D	6
	43791	FPM	O-Ring, Seat - 90D	6
	◆ 48490	EPDM	O-Ring, Seat - 90D	6
166	44038	SS	Valve	6
167	44039	SS	Spring	6

EXPLODED VIEW

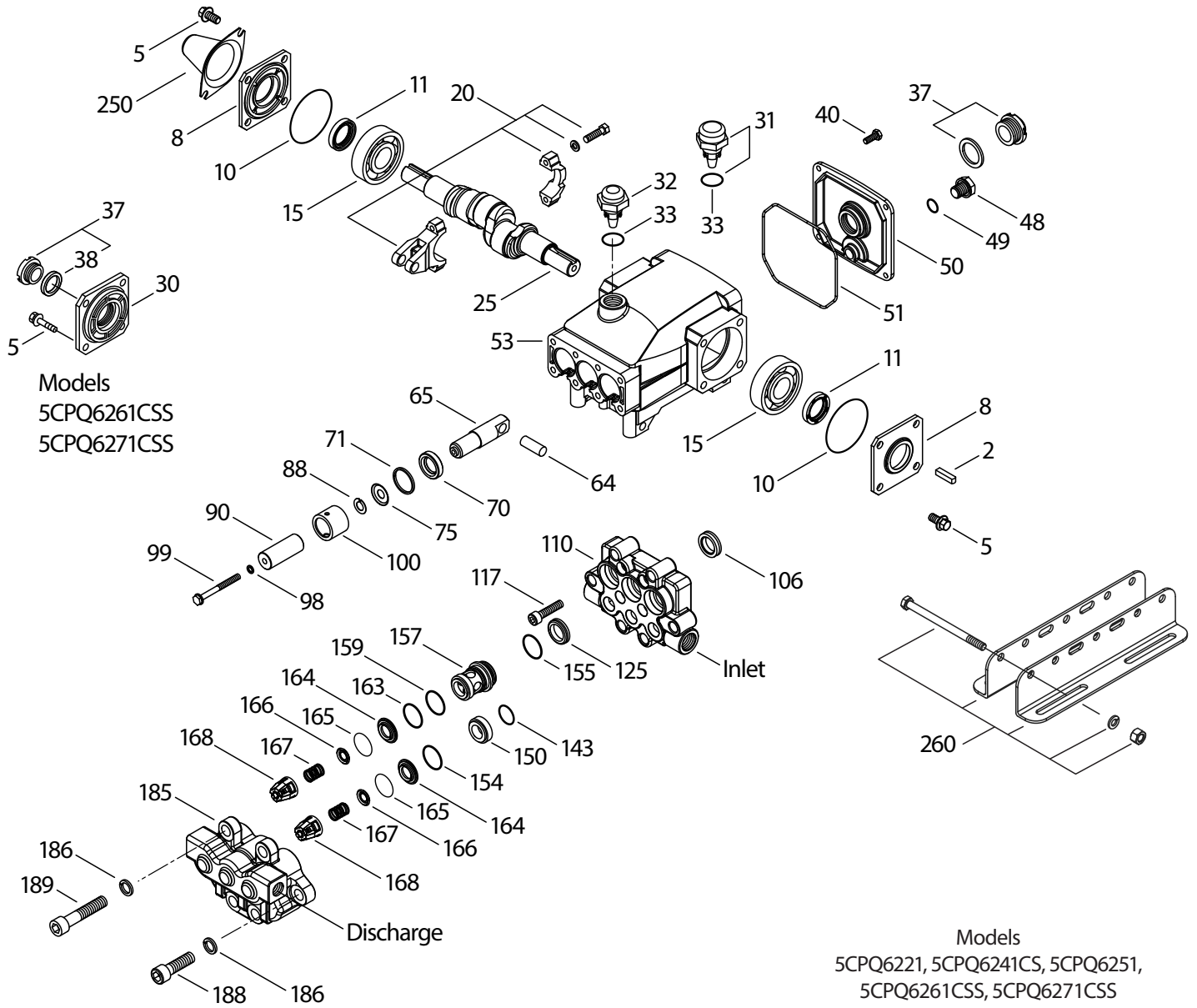

ITEM	PART NUMBER	MATL	DESCRIPTION	QTY
168	44564	PVDF	Retainer, Spring	6
185	48554	SS	Manifold, Discharge	1
186	19085	S	Lockwasher, Split (M12)	6
188	120774	S	Screw, HSH (M12x40)	2
189	89575	S	Screw, HSH (M12x60)	4
250	118672	STCP	Protector, Shaft (Models 5CPQ6221, 5CPQ6251)	1
260	30611	STZP	Mount, Rail Assy	1
300	76283	NBR	Kit, Seal (Incls: 98,106,125,143,154,155,159) STD	1
	34351	FPM	Kit, Seal (Incls: 98,106,125,143,154,155,159) .0110	1
	◆ 34352	EPDM	Kit, Seal (Incls: 98,106,125,143,154,155,159) .0220	1
310	33972	NBR	Kit, Valve (Incls: 143,154,163,164,165,166,167,168) STD	1
	34362	FPM	Kit, Valve (Incls: 143,154,163,164,165,166,167,168) .0110	1
	◆ 34363	EPDM	Kit, Valve (Incls: 143,154,163,164,165,166,167,168) .0220	1
—	6107	—	Oil, Bottle (21 oz.) ISO 68 Hydraulic (Fill to specified crankcase capacity prior to start-up)	1
—	6119	—	Lubricant, Antiseize (2.0 oz.)	1

Bold print part numbers are unique to a particular pump model. *Italics are optional items.* [] Date of latest production change.

◆ Silicone oil/grease required. † Production parts are different than repair parts.

See Tech Bulletins 002, 003, 024, 036, 043, 053, 056, 074, 083, 088 and 095 for additional information.

MATERIAL CODES (Not Part of Part Number): AL=Aluminum BBNP=Brass/Nickel Plated CC=Ceramic CM=Chrome-moly EPDM=Ethylene Propylene Diene Monomer

FCM=Forged Chrome-Moly FPM=Fluorocarbon NBR=Medium Nitrile (Buna-N) PVDF=Polyvinylidene Fluoride S=304SS SS=316SS SNG=Special Blend (Buna) STCP=Steel/Chrome Plated STZP=Steel/Zinc Plated STL=Steel TNM=Special High Strength

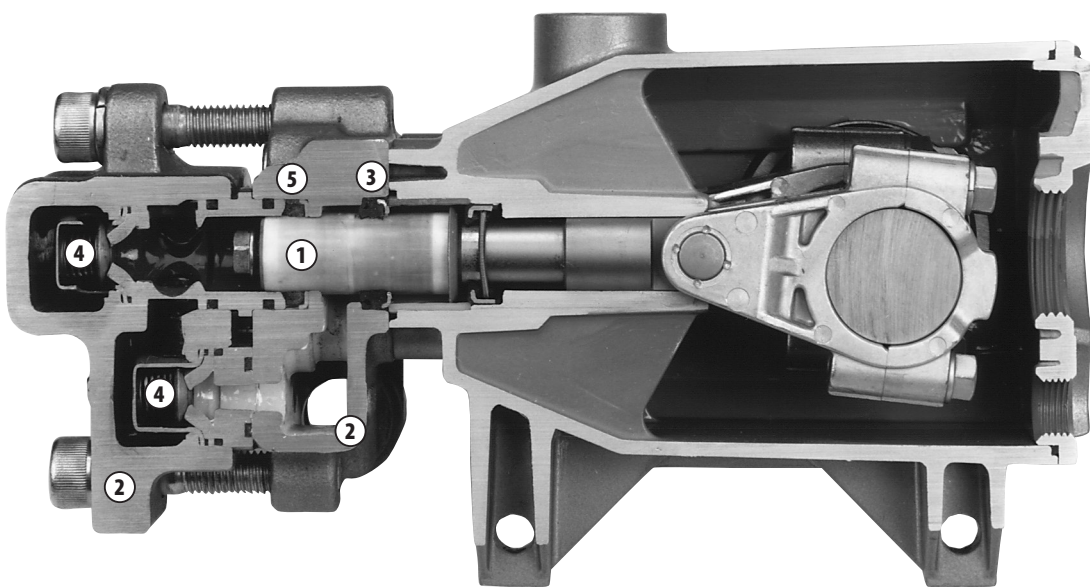
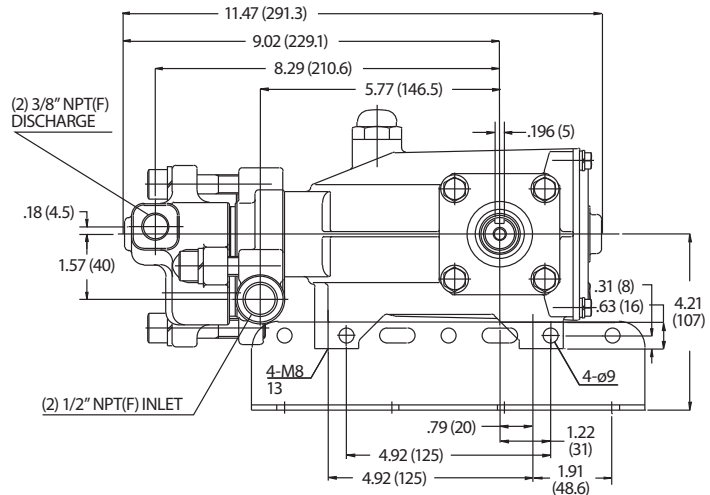
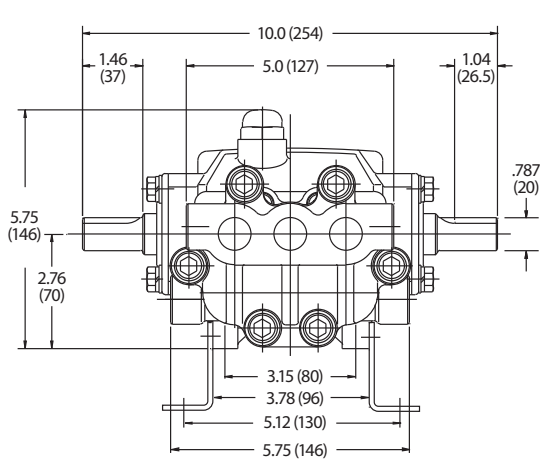

1. Special concentric, high-density, polished, solid ceramic plungers provide a true wear surface and extended seal life.
2. Manifolds are high tensile strength 316 stainless steel for liquid compatibility and long term, continuous duty.
3. 100% wet seal design adds to service life by allowing pumped liquids to cool and lubricate on both sides.
4. 316 stainless steel valves, seats and springs provide corrosion-resistance, ultimate seating and extended life.
5. Specially formulated, Cat Pump exclusive, Hi-Pressure Seals offer unmatched performance and seal life.

⚠ CAUTIONS AND WARNINGS

All High Pressure Systems require a primary pressure regulating device (i.e. regulator, unloader) and a secondary pressure relief device (i.e. pop-off valve, relief valve). Failure to install such relief devices could result in personal injury or damage to pump or property. Cat Pumps does not assume any liability or responsibility for the operation of a customer's high pressure system.

Read all CAUTIONS and WARNINGS before commencing service or operation of any high pressure system. The CAUTIONS and WARNINGS are included in each service manual and with each Accessory Data sheet. CAUTIONS and WARNINGS can also be viewed online at www.catpumps.com/cautions-warnings or can be requested directly from Cat Pumps.

WARRANTY

View the Limited Warranty on-line at www.catpumps.com/warranty.



CAT PUMPS
1681 - 94TH LANE N.E. MINNEAPOLIS, MN 55449-4324
PHONE (763) 780-5440 — FAX (763) 780-2958
e-mail: techsupport@catpumps.com
www.catpumps.com