

DATA SHEET

PRESSURE REGULATOR



Brass Model: 7189



(Panel bracket assembly sold separately)

FEATURES

- Maintains full pressure while running in idle for quick return to system pressure.
- Adjusting cap permits easy adjustments of pressure.
- Compact size and easy installation.
- Panel mounting bracket available.

SPECIFICATIONS

	U.S.	Metric
Flow Range	0.5 - 6.6 gpm	1.9 - 24.9 lpm
Pressure Range	100 - 650 psi	6.9 - 45 bar
Max Temperature	194° F	90° C
Inlet/Outlet Ports	3/8" NPT(F)	3/8" NPT(F)
By-Pass Port (Bottom)	3/8" NPT(F)	3/8" NPT(F)
Weight	13.57 oz.	0.36 kg
Dimensions	4.37 x 1.89 x 1.18"	111 x 48 x 30 mm

EXPLODED VIEW

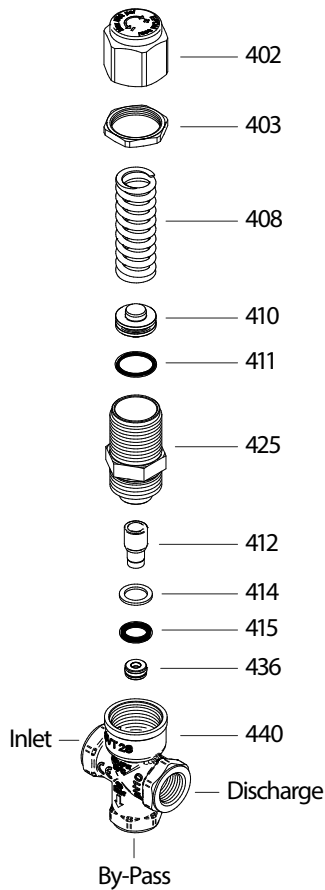

BRACKET VIEW

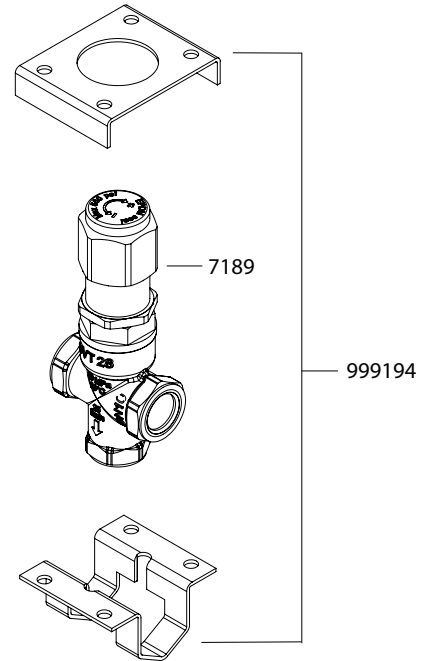

PARTS LIST

ITEM	P/N	MATL	DESCRIPTION	QTY
402	—	BB	Cap, Hex Adjusting	1
403	—	BB	Nut, Locking	1
408	—	STL	Spring, Pressure	1
410	—	BB	Retainer, Spring	1
411	—	NBR	O-Ring, Spring Retainer - 70D	1
412	—	S	Stem, Piston	1
414	—	PTFE	Backup-Ring, Piston Stem	1
415	—	EPDM	O-Ring, Piston Stem	1
425	—	BB	Retainer, Pistion	1
436	—	S	Seat, with NBR O-Ring - 90D	1
440	—	BB	Body	1
470	76027	NBR	Kit, Repair (Incls: 411, 412, 414, 415, 436)	1
471	999194	STZP	Assembly, Panel Bracket (Hardware not included)	1

Italics are optional items. Material Codes (Not Part of Part Number): BB= Brass
 EPDM= Ethylene Propylene Diene Monomer NBR= Medium Nitrile (Buna-N)
 PTFE= Pure Polytetrafluoroethylene S= 304SS STL= Steel
 STZP= Steel/Zinc Plated

⚠ CAUTIONS AND WARNINGS

All High Pressure Systems require a primary pressure regulating device (i.e. regulator, unloader) and a secondary pressure relief device (i.e. pop-off valve, relief valve). Failure to install such relief devices could result in personal injury or damage to pump or property. Cat Pumps does not assume any liability or responsibility for the operation of a customer's high pressure system.

Read all CAUTIONS and WARNINGS before commencing service or operation of any high pressure system. The CAUTIONS and WARNINGS are included in each service manual and with each Accessory Data sheet. CAUTIONS and WARNINGS can also be viewed online at www.catpumps.com/cautions-warnings or can be requested directly from Cat Pumps.

WARRANTY

View the Limited Warranty on-line at www.catpumps.com/warranty.