

DATA SHEET

7CP PLUNGER PUMPS



Brass Models: 7CP6110CS, 7CP6170

Brass Gearbox Models: 7CP6110CSG1, 7CP6170G1

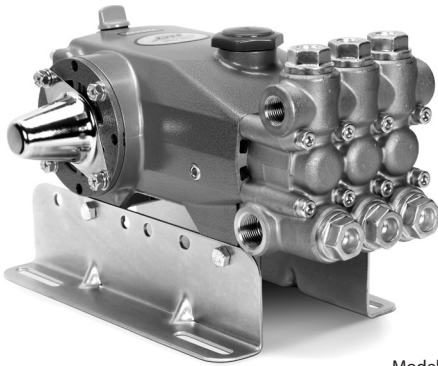

Model 7CP6170 Shown
(Rails and shaft protector sold separately)

FEATURES

- Forged brass manifold head.
- Flexible coupling/bell housing, gearbox and belt drive options provide flexibility with a compact footprint.
- Gearbox model available with 1" and 1-1/8" hollow shaft to fit a wide variety of engines.
- Standard NBR seals with alternative options for temperature and chemical compatibility.

COMMON SPECIFICATIONS

	U.S.	Metric
Inlet Pressure Range	Flooded to 70 psi	Flooded to 4.9 bar
Max. Liquid Temperature (NBR)	140° F	60° C
Alternative seals available for high temp up to 190° F		
Bore	0.866"	22 mm
Crankcase Capacity	38 oz.	1.15 l
Inlet Ports (2)	3/4" NPT(F)	3/4" NPT(F)
Discharge Ports (2)	1/2" NPT(F)	1/2" NPT(F)
Shaft Diameter	0.945"	24 mm
Weight (7CP6110CS)	29.1 lbs.	13.2 kg
Weight (7CP6170)	29.7 lbs.	13.5 kg
Weight (7CP6110CSG1, 7CP6170G1)	38.6 lbs.	17.5 kg
Dimensions (7CP6110CS)	13.46 x 9.25 x 6.89"	342 x 235 x 175 mm
Dimensions (7CP6170)	13.46 x 11.14 x 6.89"	342 x 283 x 175 mm
Dimensions (7CP6110CSG1, 7CP6170G1)	13.46 x 12.24 x 6.97"	342 x 311 x 177 mm

SPECIFICATIONS

	U.S. Measure	Metric Measure
7CP6110CS		
Flow	10.5 gpm	40 lpm
Pressure Range	100 to 2000 psi	6.9 to 138 bar
Pump RPM*	1750 rpm	1750 rpm
Stroke	0.854"	21.7 mm
7CP6170		
Flow	11 gpm	41.6 lpm
Pressure Range	100 to 2000 psi	6.9 to 138 bar
Pump RPM*	1450 rpm	1450 rpm
Stroke	1.024"	26 mm
7CP6110CSG1		
Flow	10.0 gpm	38.0 lpm
Pressure Range	100 to 2000 psi	6.9 to 138 bar
Engine RPM	3400 rpm	3400 rpm
Stroke	0.854"	21.7 mm
7CP6170G1		
Flow	12.0 gpm	45.0 lpm
Pressure Range	100 to 1800 psi	6.9 to 124 bar
Engine RPM	3264 rpm	3264 rpm
Stroke	1.024"	26 mm

*Pump minimum is 100 RPM.

ALTERNATE SPECIFICATIONS

	U.S. Measure	Metric Measure
7CP6170		
Flow	12.0 gpm	45.0 lpm
Pressure Range	100 to 1800 psi	6.9 to 124 bar
Pump RPM*	1600 rpm	1600 rpm

ALTERNATIVE SEAL CONFIGURATION

MATERIAL	SUFFIX CODE	MAXIMUM TEMPERATURE
NBR	—	140° F (60° C)
FPM	.0110	180° F (82° C)
EPDM	.0220	160° F (71° C)
HT	.3000	180° F (82° C)
STHT	.3400	190° F (88° C)

See Reference Document 99TCH002 for inlet conditions and RPM at high temperature.

PARTS LIST

ITEM	P/N	MATL	DESCRIPTION	QTY
2	30067	STL	Key (M8x7.5x25)	1
5	126540	STCP R	Screw, HHC Sems (M8x20)	8
8	131405	ALE	Cover, Bearing (See Tech Bulletin 123)	1/2
9	49503	FBR	Shim, Split, 2-Pc, Outer (See Tech Bulletin 123)	0-6
10	12393	NBR	O-Ring, Bearing Cover - 70D	2
11	49190	NBR	Seal, Oil Crankshaft	1/2
12	49504	S	Shim, Split, 2-Pc, Inner (See Tech Bulletin 123)	0-4
15	63479	STL	Bearing, Roller	2
20	48727	TNM	Rod, Connecting Assy [2/03]	3
25	49498	FCM	Crankshaft, Single-End (M21.7) (7CP6110CS, 7CP6110CSG1)	1
	49649	FCM	Crankshaft, Single-End (M26) (7CP6170G1)	1
	46963	FCM	Crankshaft, Dual-End (M26) (7CP6170)	1
30	131407	ALE	Cover, Blind Bearing (7CP6110CS, 7CP6110CSG1, 7CP6170G1) (See Tech Bulletin 123)	1
31	828710	—	Protector, Oil Cap w/Foam Gasket	1
32	43211	ABS	Cap, Oil Filler	1
33	14177	NBR	O-Ring, Oil Filler Cap - 70D	1
36	129343	RBR	Gasket, Flat	1
37	92241	PC	Gauge, Oil, Bubble w/Gasket - 80D	1
38	44428	NBR	Gasket, Flat, Oil Gauge - 80D	1
39	49948	ABS	Stick, Dip [11/12] (See Reference Bulletin 005)	1
40	125824	STCP R	Screw, HHC Sems (M6x16)	4
48	25625	STCP	Plug, Drain (1/4"x19BSP)	1
49	23170	NBR	O-Ring, Drain Plug - 70D	1
50	131403	ALE	Cover, Rear (See Tech Bulletin 123)	1
51	14030	NBR	O-Ring, Rear Cover - 70D	1
53	131400	ALE	Crankcase (See Tech Bulletin 123)	1
64	46969	CM	Pin, Crosshead	3
65	46968	BBNP	Rod, Plunger	3
70	48281	NBR	Seal, Oil Crankcase	3
75	43328	S	Slinger, Barrier	3
90	48559	CC	Plunger, Ceramic (M22x55)	3
95	126555	STCP R	Stud, Plunger Retainer (M6x50)	3
96	43235	PTFE	Back-up-Ring, Plunger Retainer	3
97	17399	NBR	O-Ring, Plunger Retainer - 80D	3
	14160	FPM	O-Ring, Plunger Retainer - 80D	3
	◆ 46204	EPDM	O-Ring, Plunger Retainer - 70D	3
98	45891	CU	Gasket	3
99	46504	S	Retainer, Plunger (M6)	3
100	46964	NY	Retainer, Seal	3
106	49644	NBR	Seal, LPS w/SS-Spg	3
	49704	FPM	Seal, LPS w/SS-Spg	3
	◆ 48650	EPDM	Seal, LPS w/SS-Spg	3
	76704	ST	Seal, LPS w/S-Spg	3
120	48279	BB	Case, Seal	3
121	13984	NBR	O-Ring, Seal Case - 70D	3
	14333	FPM	O-Ring, Seal Case	3
	◆ 48649	EPDM	O-Ring, Seal Case	3
127	48278	STG	V-Packing	6
128	48280	BB	Adapter, Male	3
162	43248	PTFE	Back-up-Ring, Seat	6
163	43249	NBR	O-Ring, Seat - 80D	6
	44383	FPM	O-Ring, Seat - 70D	6
	◆ 46206	EPDM	O-Ring, Seat - 70D	6
164	44718	S	Seat	6
166	43721	S	Valve	6
167	43751	S	Spring	6
168	44564	PVDF	Retainer, Spring	6
172	17617	NBR	O-Ring, Valve Plug - 90D	6
	11691	FPM	O-Ring, Valve Plug - 90D	6
	◆ 46207	EPDM	O-Ring, Valve Plug - 70D	6
174	43850	BB	Plug, Valve	6
185	48274	FBB	Head, Manifold	1
188	126513	STCP R	Screw, HSH (M8x70)	8
250	120220	STCP	Protector, Shaft (Model 7CP6170 only)	1
260	30613	STZP R	Mount, Rail, Assy	1
269	30206	F	Pulley (10") (See Tech Bulletin 003)	1
274	33000	STL	Hub, "H", M24 (Keyway M8) (See Tech Bulletin 003)	1
283	34334	—	Kit, Oil Drain (3/8" x 24) (See Individual Data Sheet)	1
299	816764	FBB	Head, Complete w/NBR O-Rings and Seals	1

EXPLODED VIEW

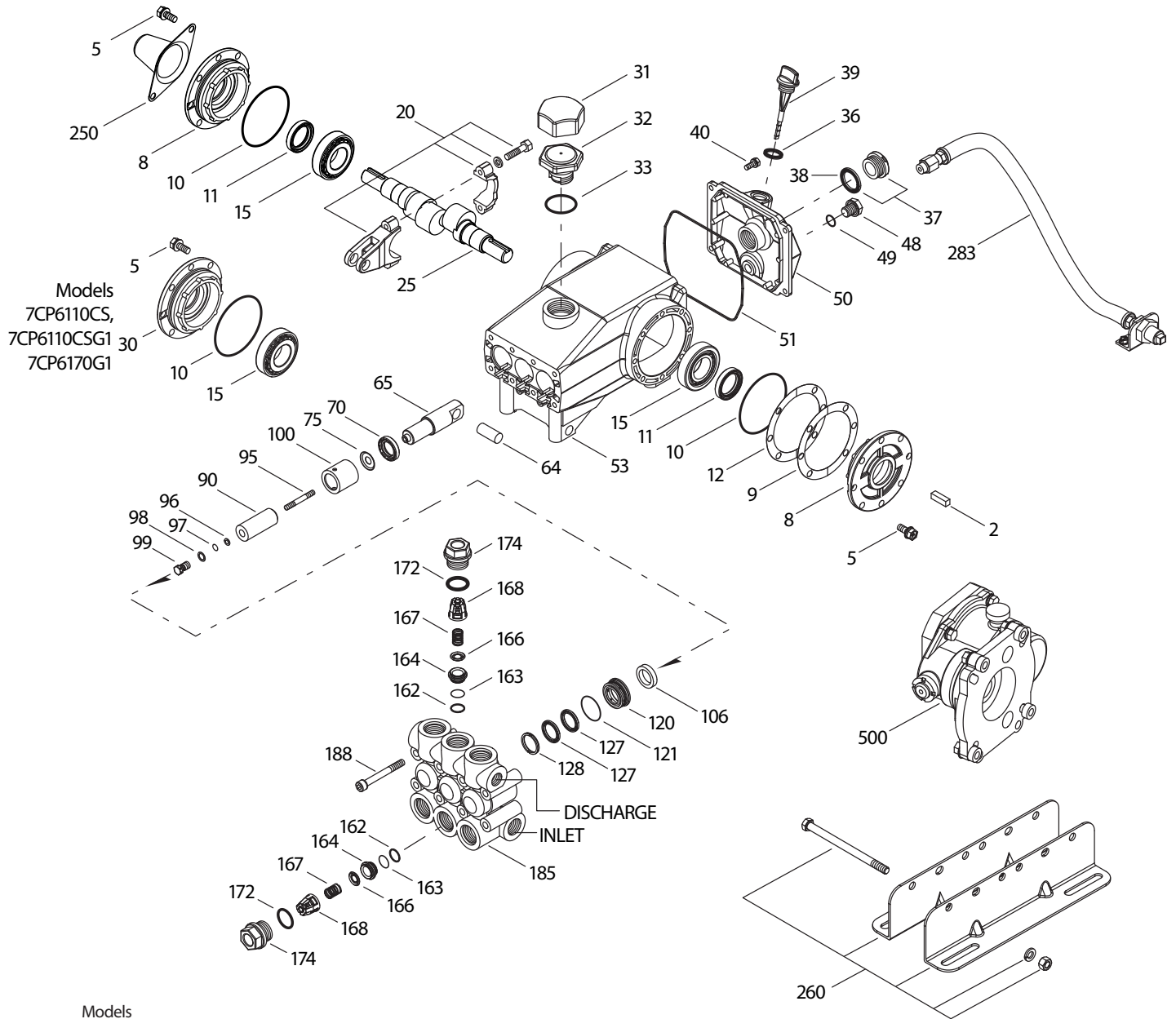

ITEM	P/N	MATL	DESCRIPTION	QTY
300	76933	NBR	Kit, Seal (Incls: 97, 106, 121, 127) Standard	1
	76950	FPM	Kit, Seal (Incls: 97, 106, 121, 127) .0110	1
	◆ 31936	EPDM*	Kit, Seal (Incls: 97, 106, 121, 127) .0220	1
	76068	STHT	Kit, Seal (Incls: 97, 106, 121, 127) .3400	1
310	34920	NBR	Kit, Valve Pre-Assembled (Incls: 162, 163, 164, 166, 167, 168, 172) Standard, .3400	2
	31256	FPM	Kit, Valve Pre-Assembled (Incls: 162, 163, 164, 166, 167, 168, 172) .0110	2
	◆ 31253	EPDM	Kit, Valve Pre-Assembled (Incls: 162, 163, 164, 166, 167, 168, 172) .0220	2
500	8081	—	Gearbox (See Individual Data Sheet)	1
	6107	—	Oil, Bottle (21 oz.) ISO 68 Hydraulic (Fill to specified crankcase capacity prior to start-up)	1-2

Bold print part numbers are unique to a particular pump model. Italics are optional items. [] Date of latest production change. ◆ Silicone oil/grease required. †Production parts are different than repair parts. R Components comply with RoHS Directive. *Review individual parts in each kit for material code identification.

For additional technical information see www.catpumps.com/literature/tech-bulletins. View Reference Bulletin 005.

MATERIAL CODES (Not Part of Part Number): ABS=ABS Plastic ALE=Aluminum Epoxy BB=Brass BBNP=Brass/Nickel Plated CC=Ceramic CM=Chrome-moly
 CU=Copper EPDM=Ethylene Propylene Diene Monomer F=Cast Iron FBB=Forged Brass FBR=Fiber FCM=Forged Chrome-moly FPM=Fluorocarbon
 NBR=Medium Nitrile (Buna-N) NY=Nylon PC=Poly Carbonate PTFE=Pure Polytetrafluoroethylene PVDF=Polyvinylidene Fluoride RBR=Rubber
 S=304SS ST= Special PTFE STG=Special Blend PTFE White STHT=Special PTFE High Temp STL=Steel
 STCP=Steel/Chrome Plated STZP=Steel/Zinc Plated TNM=Special High Strength

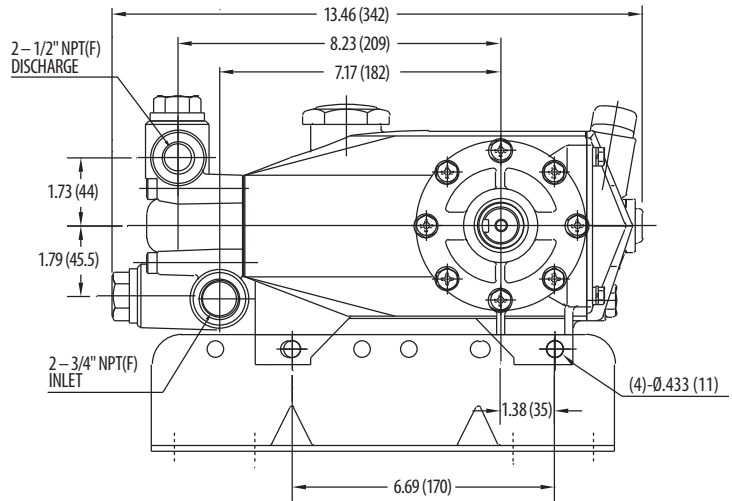
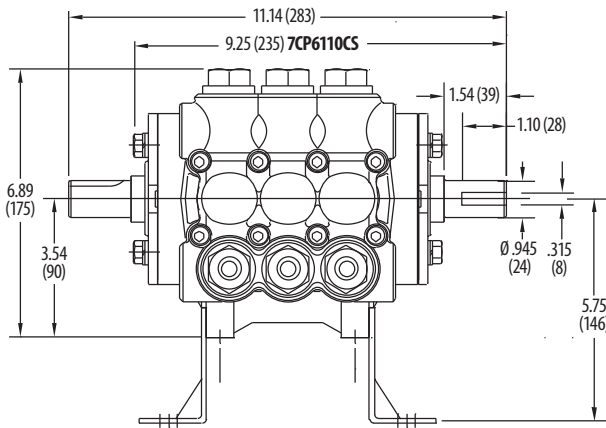

Model 7CP6170

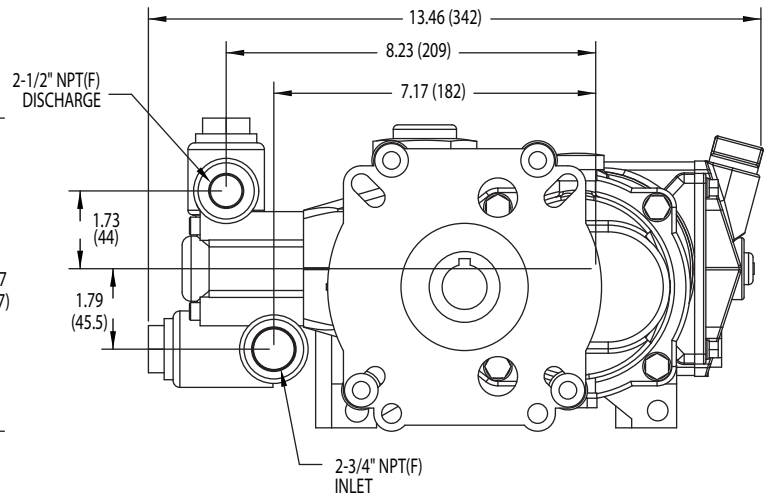
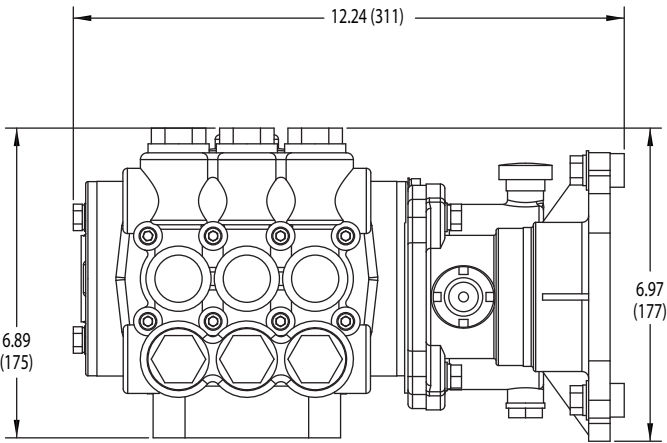

Models 7CP6110CSG1, 7CP6170G1

⚠ CAUTIONS AND WARNINGS

All High Pressure Systems require a primary pressure regulating device (i.e. regulator, unloader) and a secondary pressure relief device (i.e. pop-off valve, relief valve). Failure to install such relief devices could result in personal injury or damage to pump or property. Cat Pumps does not assume any liability or responsibility for the operation of a customer's high pressure system.

Read all CAUTIONS and WARNINGS before commencing service or operation of any high pressure system. The CAUTIONS and WARNINGS are included in each service manual and with each Accessory Data sheet. CAUTIONS and WARNINGS can also be viewed online at www.catpumps.com/cautions-warnings or can be requested directly from Cat Pumps.

WARRANTY

View the Limited Warranty on-line at www.catpumps.com/warranty.