

MODEL 3507CM.CO2



SPECIFICATIONS	U.S. Measure	Metric Measure
Flow	3.5 gpm	13.2 lpm
Pressure Range	100 – 5000 psi	6.9 – 345 bar
Pump RPM*	450	450
Inlet Pressure Range**	300 – 400 psi	21 – 27.5 bar
Min. Liquid Temperature	-20° F	-29° C
Bore	0.787"	20 mm
Stroke	1.890"	48 mm
Crankcase Capacity	4.2 Qts.	4 l
Inlet Ports (2)	1 1/2" NPT(F)	1 1/2" NPT(F)

SPECIFICATIONS	U.S. Measure	Metric Measure
Flushing Ports (2)	1/4" NPT(F)	1/4" NPT(F)
Discharge Ports (2)	3/4" NPT(F)	3/4" NPT(F)
Shaft Diameter	1.378"	35 mm
Pulley Mounting	Either Side	Either Side
Weight	152 lbs.	69 kg
Dimensions	24.51 x 18.11 x 9.72"	623 x 460 x 247 mm
Weight	152 lbs.	69 kg

* Pump minimum is 100 RPM.

** Temperature and pressure must be maintained to keep incoming CO₂ in a liquid state.

EXPLODED VIEW

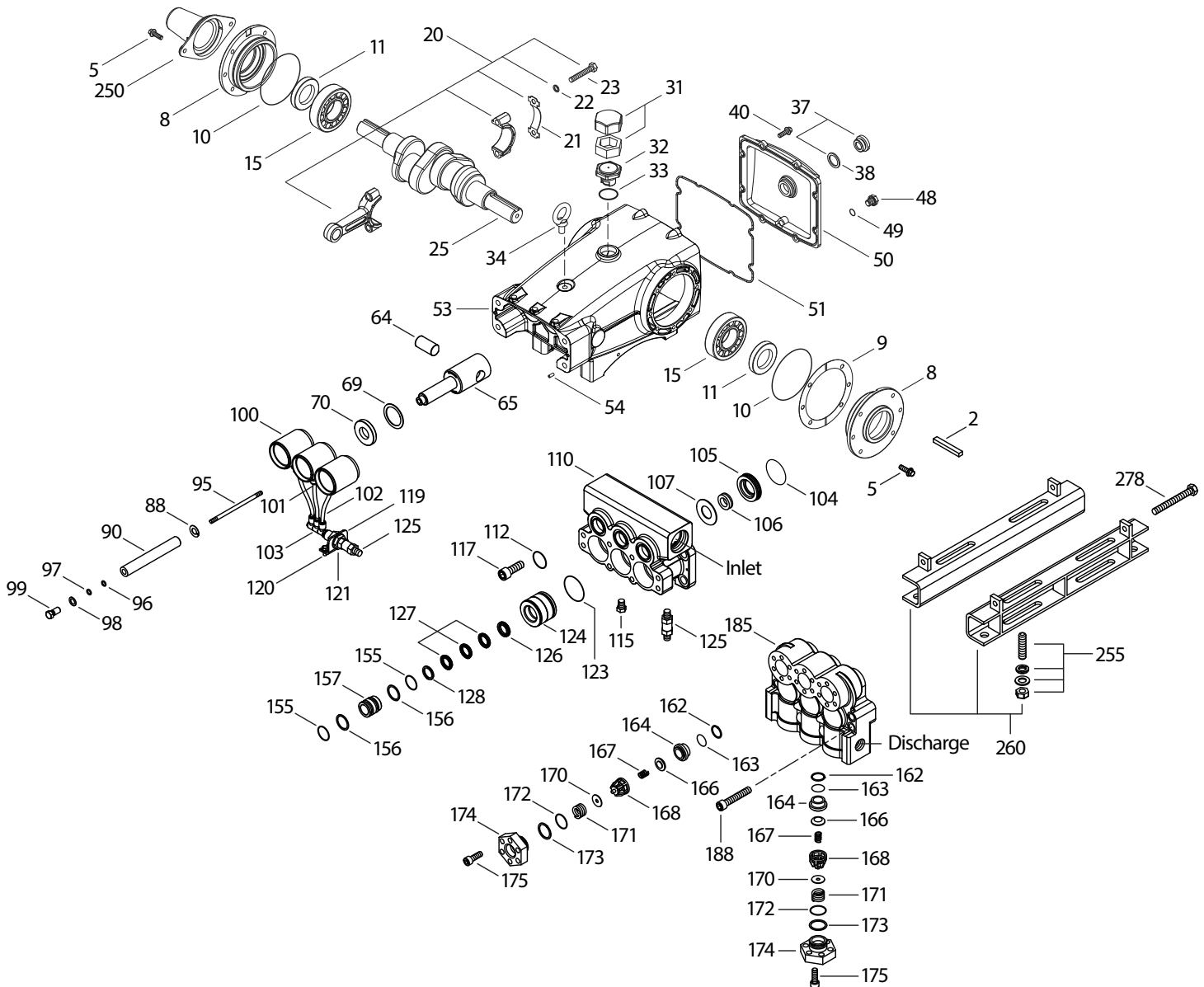

(Parts List on Reverse Side)

April 2020

PARTS LIST

ITEM	PN	MATL	DESCRIPTION	QTY	ITEM	PN	MATL	DESCRIPTION	QTY
2	34021	STL	Key (M10x8x70)	1	106	701974	SFTB	Seal, LPS, NIH-Spg	3
5	96049	S	Screw, HH Sems (M10x25) (See Tech Bulletin 125)	8	107	44074	SS	Washer, LPS	3
8	134604	ALE	Covering, Bearing (See Tech Bulletin 118,125)	2	110	125970	NAB	Manifold, Inlet, Flushed	1
9	815279	FBR	Shim, Split 2-Pc (See Tech Bulletin 125)	0-2	112	11379	NBR	O-Ring, Inlet Spacer - 70D	3
10	12398	NBR	O-Ring, Bearing Cover - 70D	2	115	22177	BBCP	Plug [1/4" NPT(M)]	1
11	13296	NBR	Seal, Oil, Crankshaft	2	117	44585	S	Screw, HSH (M14x40)	4
15	29326	STL	Bearing, Roller	2	119	34347	STZP	Bracket	1
20	761467	TNM	Assembly, Connecting Rod (Incls: 21,22,23)	3	120	990776	STZP R	Screw, HHC (1/4" - 20 x 1/2")	2
21	126749	STCP R	Washer, Locking (M10)	3	121	34338	BB	Union [1/4" NPT(M)]	1
22	126593	STCP R	Shim, Washer (M10.5x1.5)	6	123	12391	NBR	O-Ring, V-Packing Cylinder - 70D	3
23	122045	STZP	Screw, HH (M10x55)	6	124	44075	NAB	Cylinder, V-Packing	3
25	29325	FCM	Crankshaft, Dual End (M48)	1	125	33937	SS	Valve, Check [1/4" NPT(M)]	2
31	828710	PE	Protector, Oil Cap w/Polyurethane Gasket	1	126	44076	NAB	Adapter, Female	3
32	43211	ABS	Cap, Oil Filler	1	127	44607	STG	V-Packing	9
33	14177	NBR	O-Ring, Oil Filler Cap - 70D	1	128	44077	NAB	Adapter, Male	3
34	126743	STCP R	Bolt, Eye (M12x1.75) (For Lifting Pump Only)	1	155	17622	NBR	O-Ring, V-Packing Spacer	6
37	92241	PC	Gauge, Oil, Bubble w/Gasket	1	156	28675	PTFE	Back-up-Ring, V-Packing Spacer	6
38	44428	NBR	Gasket, Flat, Oil Gauge	1	157	46668	SS	Spacer, V-Packing	3
40	125753	S	Screw, HH Sems (M8x25)	1	162	21985	PTFE	Back-up-Ring, Seat	6
48	25625	STCP	Plug, Drain (1/4" x19BSP)	8	163	26089	NBR	O-Ring, Seat - 80D	6
49	23170	NBR	O-Ring, Drain Plug - 70D	1	164	44080	SS	Seat	6
50	45936	ALE	Cover, Rear (See Tech Bulletin 118)	1	166	44081	SS	Valve	6
51	16612	NBR	O-Ring, Rear Cover - 70D	1	167	44082	SS	Spring	6
53	134784	ALE	Crankcase Assy (Incls: 34,54) (See Tech Bulletin 118,125)	1	168	44735	PVDF	Retainer, Spring	6
54	27488	S	Pin, Guide	2	170	44794	SS	Washer, Spring Retainer	6
64	763864	CM	Pin, Crosshead	3	171	44793	SS	Spring, Coil, Valve Plug	6
65	765118	SSZZ	Rod, Plunger	3	172	15853	NBR	O-Ring, Valve Plug - 70D	6
69	126587	STCP R	Washer, Oil Seal	3	173	20224	PTFE	Back-up-Ring, Valve Plug	6
70	100488	NBR	Seal, Oil, Crankcase	3	174	44795	NAB	Plug, Valve	6
88	45675	S	Washer, Keyhole	3	175	87951	S	Screw, HSH, Valve Plug (M10x30)	36
90	43945	CC	Plunger (M20x145)	3	185	46561	NAB	Manifold, Discharge	1
95	89779	S	Stud, Plunger Retainer (M7 x 123)	3	188	89981	S	Screw, HSH (M12x70)	8
96	20184	PTFE	Back-up-Ring, Plunger Retainer	3	250	855042	NY	Protector, Shaft (See Tech Bulletin 125)	1
97	14190	NBR	O-Ring, Plunger Retainer - 70D	3	255	34039	S	Mount, Direct	1
98	44069	SS	Gasket, Plunger Retainer	3	260	92674	STZP R	Mount, Rail Assembly	1
99	44068	SS	Retainer, Plunger (M7)	3	278	80540	ZP	Rail Adjusting Screw, HH (M12x100)	2
100	999324	AL	Retainer, Seal	3	290	6124	—	Gasket, Liquid (3 oz.)	1
101	999490	D	Adapter, 1/4"	3	299	901389	SS	Head, Complete	1
102	999492	NY	Tubing, 1/4"	3	300	77062	NBR*	Kit, Seal (Incls: 97, 104, 106, 112, 123, 127, 155, 156)	1
103	999491	PLM	Manifold [3"x1/4" NPT(M)]	1	310	34151	NBR	Kit, Valve Preamsembled (Incls: 162-164, 166-168, 170-173)	2
104	43875	NBR	O-Ring, Inlet Adapter - 70D	3	—	6100	—	Oil, Case (12-21 oz. Bottles) ISO-68 Hydraulic (Fill to specified crankcase capacity prior to start-up)	1
105	44073	NAB	Adapter, Inlet	3					

*Review individual parts in each kit for material code identification. Italics are optional items. R Components comply with RoHS Directive.

For additional technical information see www.catpumps.com/literature/tech-bulletins.

MATERIAL CODES (Not Part of Part Number): ABS=ABS Plastic AL=Aluminum ALE=Aluminum Epoxy BB=Brass BBCP=Brass/Chrome Plated CC=Ceramic CM=ChromeMoly D=Acetal FBR=Fiber FCM=Forged Chrome-Moly NAB=Nickel Aluminum Bronze NBR=Medium Nitrile (Buna-N) NBRs=Buna Silicone Free NY=Nylon PC= Poly Carbonate PE=Polyethylene PLM=Unspecified Poly PTFE=Pure Polytetrafluoroethylene PVDF=Polyvinylidene Fluoride S=304SS SFTB=Special Blend PTFE Black SS=316SS STG=Special Blend PTFE White SSZZ=316SS/Zamak STCP=Steel/Chrome Plated STL=Steel STZP=Steel/Zinc Plated TNM=Special High Strength ZP=Zinc Plated

⚠ CAUTIONS AND WARNINGS

All High-Pressure Systems require a primary pressure regulating device (i.e. regulator, unloader) and a secondary pressure relief device (i.e. pop-off valve, relief valve). Failure to install such relief devices could result in personal injury or damage to pump or property. Cat Pumps does not assume any liability or responsibility for the operation of a customer's high-pressure system.

Read all CAUTIONS and WARNINGS before commencing service or operation of any high-pressure system. The CAUTIONS and WARNINGS are included in each Service Manual and with each Accessory Data sheet. CAUTIONS and WARNINGS can also be viewed online at www.catpumps.com/dynamic-literature/cautions-and-warnings or can be requested directly from Cat Pumps.

WARRANTY

View the Limited Warranty on-line at www.catpumps.com/warranty.