

DATA SHEET

PULSATION DAMPENERS



Carbon Steel Models: **6011, 6012**

**Carbon Steel/
Stainless Steel Model:** **6018**

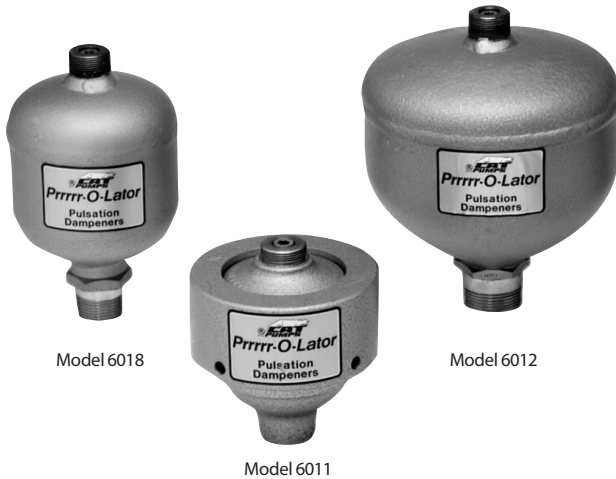

Model 6018

Model 6011

Model 6012

FEATURES

- Nitrogen precharged to eliminate moisture and bladder deterioration.
- Broader bladder design provides greater pulsation reduction for smoother performance and longer system component life.
- Sealed valve for positive pressure lock

SHIPMENT REGULATIONS

- Pre-charged pulsation dampeners are defined as hazardous articles. **These articles use the proper shipping name of "Articles, Pressurized, Hydraulic" and use the identification number of "UN3164."**
- Uncharged pulsation dampeners require no special handling and can be shipped via standard shipping methods.
- All domestic shipments of hazardous articles must follow Department of Transportation CFR 49, parts 100 to 185 regulations (DOT).
- International shipments of hazardous articles must follow either International Air Transport Association regulation (IATA) or International Maritime Dangerous Goods Codes (IMDG).

ORDERING INFORMATION

Use base part number for rechargeable models 6011, 6012 or 6018 if factory pre-charge is desired.

Add .800 to base part number for rechargeable models (i.e. 6012.800) for:

1. No pre-charge (remove factory pressure)
2. A pre-charge different from factory (indicate desired pre-charge on purchase order)

Note: A handling charge will apply.

SPECIFICATIONS

	U.S.	Metric
Model 6011 - Rechargeable and Rebuildable		
Maximum Flow	25 gpm*	95 lpm
Maximum Working Pressure	7200 psi***	496 bar
Precharge	2000 psi	138 bar
Maximum Operating Temperature	180°F***	82°C
Volume	15 cu. in.	0.25 L
Safety Factor	4/1	4/1
Bladder Construction	NBR	NBR
Port Size	1/2" NPT(F)	1/2" NPT(F)
Diameter	4.5"	115 mm
Length	5.59"	142 mm
Weight	6.4 lbs.	2.9 kg

Model 6012 - Rechargeable

Maximum Flow	70 gpm*	265 lpm
Maximum Working Pressure	1500 psi	103 bar
Precharge	450 psi	31 bar
Maximum Operating Temperature	180°F	82°C
Volume	120 cu. in.	1.97 L
Safety Factor	4/1	4/1
Bladder Construction	NBR	NBR
Port Size	1-1/4" NPT(M)	1-1/4" NPT(M)
Diameter	6.7"	172 mm
Length	8.5"	217 mm
Weight	12.0 lbs.	5.44 kg

Model 6018 - Rechargeable

Maximum Flow	40 gpm*	151 lpm
Maximum Working Pressure	3000 psi**	207 bar
Precharge	450 psi	31 bar
Maximum Operating Temperature	180°F**	82°C
Volume	45 cu. in.	0.74 L
Safety Factor	4/1	4/1
Bladder Construction	NBR	NBR
Lower Body (Wetted Parts)	SS	SS
Port Size	1" NPT(M)	1" NPT(M)
Diameter	4.78"	121 mm
Length	7.57"	192 mm
Weight	7.28 lbs.	3.3 kg

*Authorized system performance. Contact Cat Pumps for continuous duty performance.

**2500 PSI maximum working pressure at 180°F temperature.

***6000 PSI maximum working pressure at 180°F temperature.

INSTALLATION INSTRUCTIONS

⚠ WARNING

Do not charge pulsation dampeners with oxygen. Oxygen may cause an explosion causing personal injury, death or property damage.

1. Use nitrogen only when charging pulsation dampeners, DO NOT USE OXYGEN.
2. Use proper charging tools to charge pulsation dampeners.
3. Charge pulsation dampener within specifications stated on data sheet to assure proper pulsation dampening and prevent failure of bladder.

SELECTION: The pulsation dampener should be selected to match the flow and pressure requirements of the system and satisfy the liquid compatibility.

INSTALLATION: The pulsation dampener should be mounted directly onto the pump discharge manifold for optimum pulsation dampening and to avoid system vibration damage. Before installing the pulsation dampener, be certain the sealed valve at the top of the pulsation dampener is securely tightened to assure no loss of pressure during operation.

OPERATION: The pulsation dampener should be precharged with **dry Nitrogen only.**

Note the standard precharge of the pulsation dampener. This may be adjusted to offer a more precise control of pulsation in critical applications such as reverse osmosis. Check this precharge every 12 months for normal operation and more frequently for continuous-duty operation.

At a standard temperature of 70°F optimum accumulator performance is obtained when the precharge is calibrated at 50% of the system operating pressure.

NOTE: When operating at the lower temperatures, precharge should be 15% higher or 65% of system pressure. When operating at higher temperatures, precharge should be 15% lower or 35% of system pressure.

NOTE: Up to 50 psi precharge pressure can be lost during the checking of your precharge.

DIMENSIONAL

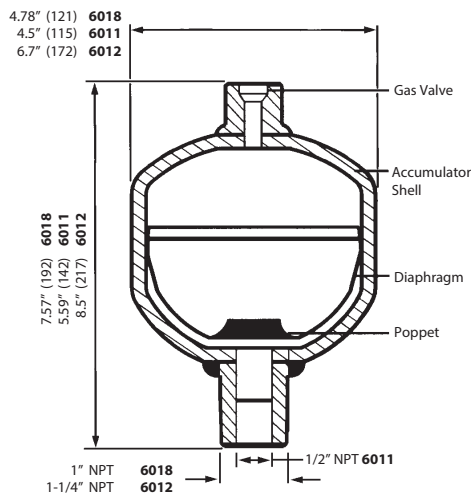

FILLING AND GAUGING INSTRUCTIONS

The following are the steps in both checking the precharge of the pulsation dampener and recharging if there should be a loss of pressure or a need for adjustment.

NOTE: A gas regulator must be mounted between the nitrogen tank and the hose connection from the Filling and Gauging Assembly to enable you to regulate 50% of the desired system pressure and to prevent excessive pressure being transmitted directly to the pulsation dampener. Over pressurization will void the warranty.

1. Before checking your precharge, system pressure should be at zero. turn system off.
2. Slightly loosen the sealed valve at the top of the pulsation dampener using a 6mm long handled allen wrench. Thread on the Filling and Gauging Assembly hand tight.
3. Be certain the side bleed valve on the gauging assembly is closed.
4. Slowly open the large "T" valve at the top of the gauging assembly until completely open. The gauge on the assembly will read the precharge on the pulsation dampener.
5. Completely back off (close) the valve on the gas regulator, open the nitrogen tank valve and read the nitrogen tank pressure on the first gauge.
6. If the reading on the gauge assembly is 50% of the system pressure, close the top "T" valve and proceed to step 9.
7. If the precharge is too high, keep the top "T" valve open and slowly open the small "T" valve on the side of the gauging assembly to bleed off pressure.
8. If the pressure is less than 50% of the system pressure, slowly open the gas regulator valve until the desired precharge is reached on the second gauge.
9. When the gauge reads the required precharge, close the "T" valve on the top of the gauging assembly to lock the precharge in the pulsation dampener.
10. Back off (close) the gas regulator.
11. Proceed with opening the small side "T" valve on the gauging assembly to relieve (bleed-off) pressure in the assembly and on the second gauge on the gas regulator.
12. Close the side "T" valve on the gauging assembly and remove the assembly from the pulsation dampener.
13. Tighten the pulsation dampener sealed valve and resume operation.

OPTIONAL TOOLS AND SPARE PARTS

- 30940 Complete Filling and Gauging Assembly (Optional)
- 30941 Allen Wrench (Included in Assembly)
- 6099 Pressure Gauge (Included in Assembly)
- 76501 Charging Screw w/ Seal Washer



WARRANTY

View the Limited Warranty on-line at www.catpumps.com/warranty.



CAT PUMPS

1681 - 94TH LANE N.E. MINNEAPOLIS, MN 55449-4324
PHONE (763) 780-5440 — FAX (763) 780-2958
e-mail: techsupport@catpumps.com
www.catpumps.com