

DATA SHEET

HIGH-PRESSURE PULSE PUMPS



**Stainless Steel
Models:**

6350, 6351

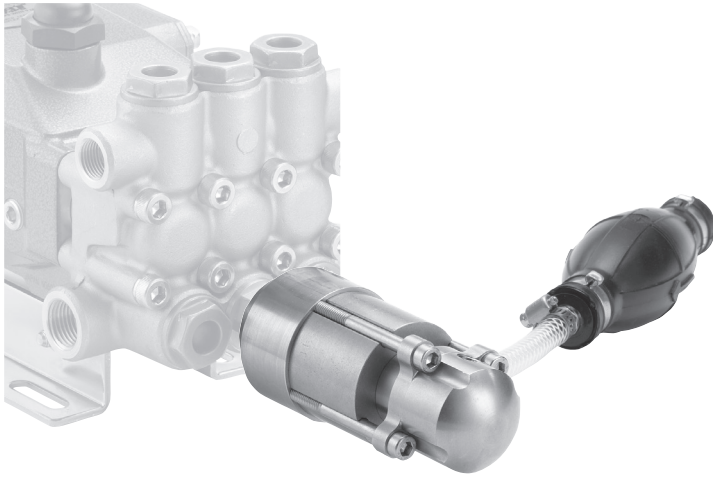

SPECIFICATIONS	U.S. Measure	Metric Measure
Pressure Range	500 – 3000 psi	35 – 207 bar
Maximum Injection Rate	12.0 gph	45.4 lph
RPM Range	300 – 1800 rpm	300 – 1800 rpm
Maximum Inlet Pressure of Drive Pump	20 psi	1.38 bar
Maximum Liquid Temp.	130° F	54° C
Inlet Port (1)	¼" Hose Barb	¼" Hose Barb
Discharge Port (1)	⅛" NPT(F)	⅛" NPT(F)
Inlet Valve Material (6350)	Acetal	Acetal
Inlet Valve Material (6351)	304SS	304SS
Weight (w/o Adapter Assy.)	2.9 lbs.	1.32 kg
Diameter	2"	51 mm
Length	5"	127 mm

MAXIMUM INJECTION RATE

Pump RPM	Injection Rate
300	3.0 gph
400	4.0 gph
500	5.0 gph
600	6.0 gph
700	7.0 gph
800	8.0 gph
900	9.0 gph
1000	10.0 gph
1100	11.0 gph
1200 – 1800	12.0 gph

FEATURES

- Permits chemical application up to 3000 psi.
- Eliminates pumping harsh chemicals through the main pump.
- Conveniently mounts with an adapter into any inlet valve chamber on the main pump.
- Standard prime bulb with check valve to initiate chemical flow.

SELECTION

Select proper adapter assembly to match the appropriate pump model.

6350, 6351 ADAPTER ASSEMBLIES

Pump Models	Adapter Assembly
335, 435	76400
3CP1120, 3CP1130, 3CP1140, 310, 340, 350, 5CP2120W, 5CP2140WCS, 5CP2150W, 5SP30ELR, 5SP35ELR, 5SP40ELR	76405
45, 5CP3105CSS, 5CP3110CSS, 5CP3120, 5CP3120CSS, 5CP3150CSS, 5CP3160CSS, 5CP5120, 5CP5135CSS, 5CP5140CSS	76410
56, 60	76626
530, 550, 650, 660, 1050, 5CP6120, 5CP6180CSS, 5CP6190, 7CP6110CS, 7CP6170	76415

INSTALLATION

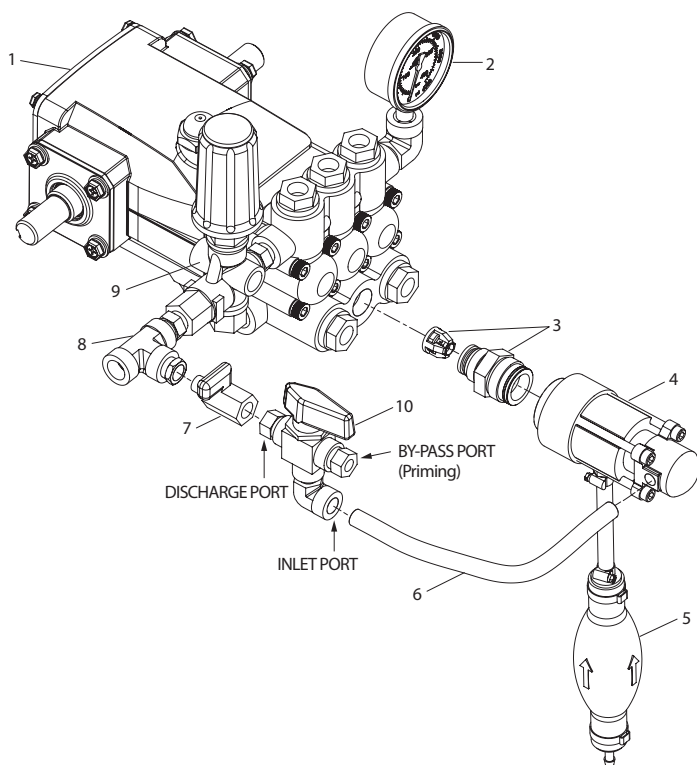

1	Plunger Pump
2	Gauge
3	Adapter Assembly
4	Pulse Pump
5	Priming Bulb
6	High-Pressure Discharge Hose
7	Metering Valve (PN 992040 or equivalent)
8	Tee
9	Unloader
10	3-way Ball Valve, closed center (PN 992043 or equivalent)
11	Check Valve (Not Shown) (PN 33937 or equivalent)

Plunger Pump Conversion

1. Remove center inlet valve plug from discharge manifold.
2. Remove complete valve assembly from valve chamber.
3. Separate spring retainer from valve seat.
4. Install modified spring retainer from adapter assembly onto valve seat.
5. Install modified valve assembly into center inlet valve chamber.
6. Lubricate and install new valve plug o-ring around small end of adapter body. Lubricate and install new back-up ring and then new o-ring around larger end of adapter body.
7. Thread adapter assembly into valve chamber and torque to 870 in-lbs.
8. Apply Loctite® 242® to exposed threads of adapter assembly. Thread pulse pump onto adapter assembly and position pulse pump so that ¼" NPT barb is in desired position.
9. Attach priming bulb with hose to ¼" NPT barb on pulse pump.
10. Attach any standard high pressure hose from ⅛" NPT port on pulse pump to a metering valve after the unloader.

Piston Pump Conversion

1. Remove discharge manifold from the piston pump.
2. Replace with new pulse pump manifold and associated parts, and a new flat valve kit.
3. Place pulse pump manifold with three cylinder holes facing upwards.
4. In the cylinder hole with the deeper counterbore, install one white PTFE seal washer and one spring retainer (without nylon insert).
5. Install heavy-duty spring, standard flat valve spring, flat valve, flat seat and spacer into this same deep cylinder hole.
6. In the remaining two cylinder holes, first install one white PTFE seal washer and then a complete flat valve assembly.
7. Remove existing shims from each cylinder bolt. Since the number of shims may change with the manifold, refer to Tech Bulletin 017 for proper shimming procedure and mount pulse pump manifold to pump.
8. Lubricate and install back-up ring and then o-ring on adapter assembly.
9. Thread adapter assembly into special ½" NPT(F) port on the top of the pulse pump manifold.
10. Apply Loctite® 242® to exposed threads of adapter assembly. Thread pulse pump into adapter assembly and position pulse pump so that ¼" NPT barb is in desired position.
11. Attach priming bulb with hose to ¼" NPT barb on pulse pump.
12. Attach any standard high-pressure hose from ⅛" NPT port on pulse pump to a metering valve after the unloader.

OPERATION

Note: A metering valve (PN 992040 or equivalent) and closed center 3-way ball valve (PN 992043 or equivalent) are required to properly operate the pulse pump.

1. Ensure pump is connected to a water supply but is NOT running.
 2. Open 3-way ball valve to by-pass port.
 3. Squeeze priming bulb repeatedly until chemical flows through the pulse pump and comes out the by-pass port of 3-way ball valve.
 4. Turn on water supply, open trigger gun and start up pump.
 5. Bring pump up to operating pressure and set regulating devices.
- NOTICE** Main pump inlet pressure must not exceed 20 psi.
6. Allow chemical to flow out of by-pass port of 3-way ball valve, then switch 3-way ball valve to discharge port.
 7. Adjust metering valve to the desired amount of chemical/water mixture.

Note: Optional check valve (PN 33937 or equivalent) can be located at pulse pump inlet to avoid any back flow to chemical supply as high-pressure seal assembly wears.

Note: Priming bulb can be eliminated if chemical is gravity fed.

EXPLODED VIEW

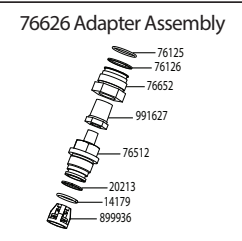
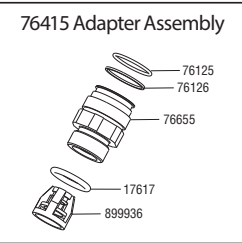
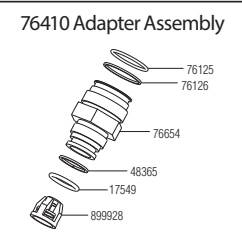
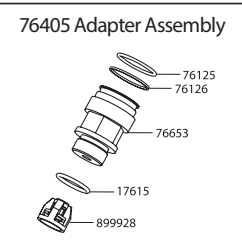
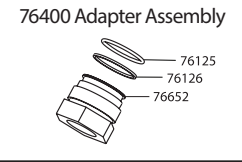
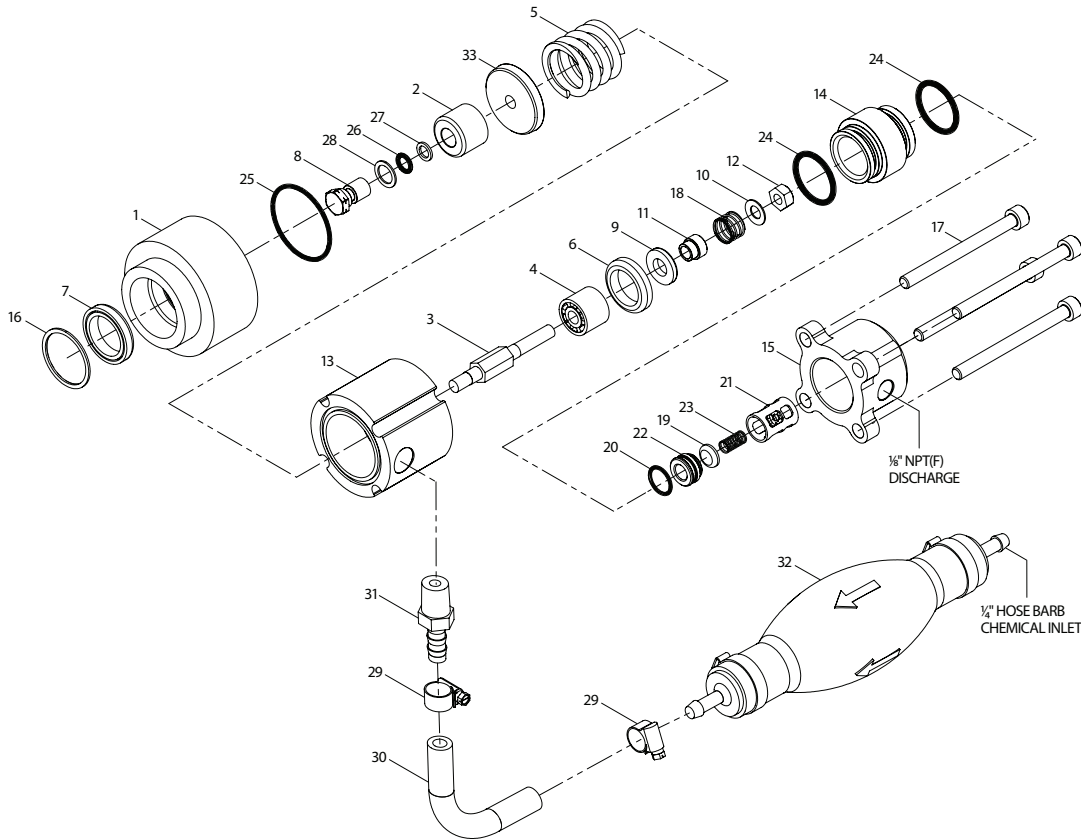

PARTS LIST

ITEM	PN	MATL	DESCRIPTION	QTY
1	—	S	Body, Pulse	1
2	49449	CC	Plunger (M20 x 15.4)	1
3	76139	S	Rod, Plunger	1
4	45847	CC	Plunger (M18 X 14)	1
5	76107	SS	Spring, Return	1
6	46652	HT*	Seal Assembly, HPS	1
7	46667	HT*	Seal Assembly, HPS	1
8	46504	S	Retainer, Plunger	1
9	33873	D	Valve, Inlet (Model 6350)	1
	45854	S	Valve, Inlet (Model 6351)	1
10	88575	S	Washer, Conical (M6)	1
11	549520	S	Spacer, Inlet	1
12	81240	S	Nut, Hex (M6)	1
13	—	S	Body, Inlet	1
14	76128	S	Cylinder	1
15	—	S	Body, Discharge	1
16	76112	S	Ring, Retainer	1
17	76119	S	Screw, HSH (M6 X 70)	4
18	44872	S	Spring	1
19	46764	S	Valve	1
20	76656	FPM	O-Ring, Discharge Valve Seat – 70D	1

ITEM	PN	MATL	DESCRIPTION	QTY
21	543988	PVDF	Retainer, Spring	1
22	545177	S	Seat	1
23	46865	S	Spring	1
24	11377	FPM	O-Ring – 80D	2
25	76113	FPM	O-Ring, Body – 75D	1
26	14160	FPM	O-Ring - 80D	1
27	43235	PTFE	Back-up Ring	1
28	44041	SS	Gasket	1
29	34365	S	Clamp, Hose 1/4"	2
30	76268	PVC	Tubing 1/4" x 4"	1
31	76651	S	Barb, Hose 1/4"	1
32	76649	RBR	Bulb, Priming w/Check Valve	1
33	76109	SS	Retainer, Stroke	1
—	76270	FPM	Kit, Seal (Includes: 6,7,16,20,24–27) (Model 6350, 6351)	1
—	76275	FPM	Kit, Valve (Includes: 9–12, 18–23) (Model 6350)	1
—	76287	FPM	Kit, Valve (Includes: 9–12, 18–23) (Model 6351)	1
—	76280	CC	Kit, Plunger (Includes: 2–5,8–12,18,26–28, 33) (Model 6350)	1
—	76288	CC	Kit, Plunger (Includes: 2–5,8–12,18,26–28, 33) (Model 6351)	1
—	992043	S	3-Way Ball Valve, Closed Center (Rated to 2500 psi)	1
—	33937	SS	Check Valve (Rated to 5000 psi)	1

Bold print part numbers are unique to a particular pump model. Italics are optional items. *Review individual parts in each kit for material identification.
 MATERIAL CODES (Not Part of Part Number): CC=Ceramic D=Acetal FPM=Fluorocarbon HT=High Temp PTFE=Pure Polytetrafluoroethylene PVC=Polyvinyl Chloride
 PVDF=Polyvinylidene Fluoride RBR=Rubber S=304SS SS=316SS **NOTE:** Pulse body and inlet body must be replaced as a set.

MAINTENANCE

⚠ WARNING

Before commencing with service, shut off drive (electric motor, gas or diesel engine) and turn off water supply to pump. Relieve all discharge line pressure by triggering gun or opening valve in discharge line.

Pulse Pump Disassembly

1. Remove four hex socket head cap screws with a 5mm allen wrench.
2. Separate and remove discharge body from cylinder.
3. Grasp plastic spring retainer and pull valve assembly from cylinder.
4. Remove cylinder with o-rings from inlet body.
5. Separate and remove inlet body from pulse body.
6. Remove two-piece high-pressure seal from inlet body.
7. Remove large return spring.
8. Grasp end of plunger assembly and pull from pulse body.
9. To remove the M18 ceramic plunger, use a $\frac{3}{8}$ " open end wrench on the hex part of the plunger rod for support and with a 10mm open end wrench remove nut. Next remove conical washer, spring, inlet spacer, inlet valve and ceramic plunger.
10. To remove the M20 ceramic plunger, use a $\frac{3}{8}$ " open-end wrench on the hex part of the plunger rod for support and with a 11mm open-end wrench remove the plunger retainer. Next remove the gasket, o-ring and ceramic plunger from the plunger retainer. The retainer and spring can also be removed.
11. Remove o-ring from pulse body.
12. Turn pulse body over. Remove snap ring from threaded side of pulse body.
13. Remove two-piece high-pressure seal from pulse body.

Note: Discharge port can be orientated in 90° increments by removing the four hex socket head cap screws with a 5mm allen wrench and rotating body to desired location. Re-torque to 10 ft-lbs.

Pulse Pump Reassembly

1. Examine both high-pressure seals for wear to the internal and external surfaces and replace as needed.
2. Lubricate and place one high-pressure seal (M20) with metal backing down into threaded end of the pulse body.
3. Install retainer ring to hold high-pressure seal in place.
4. Turn pulse body over and press plunger assembly with large diameter plunger down into pulse body.
5. Examine o-ring for cuts or wear and replace as needed.
6. Place o-ring into pulse body.
7. Position large return spring over plunger assembly.
8. Place inlet body with barb end closest to pulse body. Align grooves in inlet body with tapped holes of pulse body.
9. Lubricate and place one high-pressure seal (M18) with metal backing down into the smaller hole side of the inlet body.
10. Examine o-rings for cuts or wear and replace as needed.
11. Lubricate and install one o-ring on each end of the cylinder.
12. Press cylinder into inlet body with larger hole facing down.
13. Lubricate valve seat o-ring and press complete valve assembly into small hole in cylinder.
14. Place discharge body over cylinder. Ensure mounting holes line up with grooves on inlet body and threaded holes in pulse body.
15. Thread in four hex socket head cap screws by hand. Use a 5mm allen wrench to torque to 10 ft-lbs.

Loctite and 242 are registered trademarks of the Henkel Corporation.

TROUBLESHOOTING

PROBLEM	SOLUTION
No chemical supply from pulse pump	<ul style="list-style-type: none">• High inlet pressure on main pump, adjust to maximum 5 psi.• Remove air in chemical supply.• Remove foreign material in inlet or discharge valves of drive pump.• Remove foreign material in inlet or discharge valves of pulse pump.• Properly primed system.
Limited chemical supply from pulse pump	<ul style="list-style-type: none">• Replace worn inlet and discharge valves.• Remove restriction in metering hose.• Remove restriction between drive pump and pulse pump.

⚠ CAUTIONS AND WARNINGS

All high-pressure systems require a primary pressure regulating device (i.e. regulator, unloader) and a secondary pressure relief device (i.e. pop-off valve, relief valve). Failure to install such relief devices could result in personal injury or damage to pump or property. Cat Pumps does not assume any liability or responsibility for the operation of a customer's high-pressure system.

Read all CAUTIONS and WARNINGS before commencing service or operation of any high-pressure system. The CAUTIONS and WARNINGS are included in each Service Manual and with each Accessory Data sheet. CAUTIONS and WARNINGS can also be viewed online at www.catpumps.com/dynamic-literature/cautions-and-warnings or can be requested directly from Cat Pumps.

WARRANTY

View the Limited Warranty on-line at www.catpumps.com/literature/cat-pumps-limited-warranty