

DATA SHEET

5CP PLUNGER PUMPS

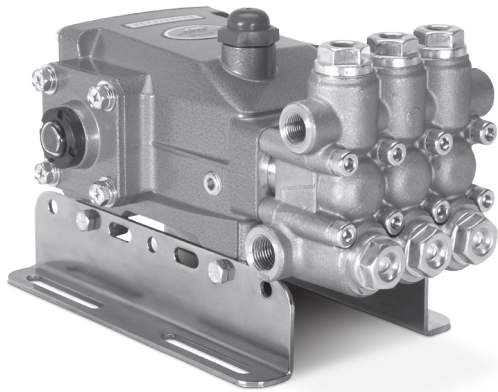

Brass Model: **5CP3150CSS**
Gearbox Model: **5CP3150CSSG1**



Model 5CP3150 Shown
(Mounting rails sold separately)

FEATURES

- Industrial triplex design offers reliability and versatility.
- Compact direct-drive mount to motor using bell housing and flexible coupling (NEMA or IEC available).
- Gearbox model available with 1" and 1-1/8" hollowshaft to fit a wide variety of engines.
- Optional belt-drive for precision flow setting.
- Press-in seal cases and interchangeable valve assemblies for easy servicing.
- Standard NBR seals with alternative options for temperature and chemical compatibility.

COMMON SPECIFICATIONS

	U.S.	Metric
Inlet Pressure Range	-2.5 to 60 psi	-2 to 4 bar
Max. Liquid Temp. (NBR)	160° F	71° C
Alternative seals available for high temp up to 190° F		
Bore	0.630"	16 mm
Crankcase Capacity	17 oz.	0.50 l
Inlet Ports (2)	1/2" NPT(F)	1/2" NPT (F)
Discharge Ports (2)	3/8" NPT (F)	3/8" NPT (F)
Shaft Diameter	0.787"	20 mm

SPECIFICATIONS

	U.S. Measure	Metric Measure
MODEL 5CP3150CSS		
Flow	5.2 gpm	19.7 lpm
Pressure Range	100 - 3000 psi	6.9 - 207 bar
Pump RPM*	1750 rpm	1750 rpm
Stroke	0.787"	20 mm
Weight	19.9 lbs.	9 kg
Dimensions	10.90 x 8.58 x 5.79"	277 x 218 x 147 mm
MODEL 5CP3150CSSG1		
Flow	5.0 gpm	18.9 lpm
Pressure Range	100 - 3000 psi	6.9 - 207 bar
Engine RPM	3450 rpm	3450 rpm
Stroke	0.787"	20 mm
Weight	26.5 lbs.	12 kg
Dimensions	11.0 x 12.7 x 6.4"	279 x 324 x 163 mm

*Pump minimum is 100 RPM.

ALTERNATIVE SEAL CONFIGURATION

MATERIAL	SUFFIX CODE	MAXIMUM TEMPERATURE	
NBR	—	160° F	(71° C)
FPM	.0110	180° F	(82° C)
EPDM	.0220	160° F	(71° C)
HT	.3000	180° F	(82° C)
STHT	.3400	190° F	(88° C)

See Reference Document 99TCH002 for inlet conditions and RPM at high temperature.

DETERMINING THE PUMP R.P.M.	Rated gpm	=	"Desired" gpm
	Rated rpm	=	"Desired" rpm
DETERMINING THE REQUIRED H.P.	Hp (Electric Brake)	=	$\frac{\text{gpm} \times \text{psi}}{1460}$
	DETERMINING MOTOR PULLEY SIZE	$\frac{\text{Motor Pulley O.D.}}{\text{Pump rpm}}$	= $\frac{\text{Pump Pulley O.D.}}{\text{Motor rpm}}$

Refer to pump **Service Manual** for repair procedure and additional technical information.

PARTS LIST

ITEM	PART NUMBER		DESCRIPTION	QTY
	5CP3150CSS			
	5CP3150CSSG1	MATL		
2	30057	STL	Key (M6x6x25)	1
5	126542	STCP R	Screw, HHC, Sems (M8x16)	8
8	46910	AL	Cover, Bearing	1
10	14028	NBR	O-Ring, Bearing Cover - 70D	2
11	43222	NBR	Seal, Oil, Crankshaft - 70D	1
15	14480	STL	Bearing, Ball	2
20	48742	TNM	Rod, Connecting Assy [10/01]	3
25	49773	FCM	Crankshaft, Single End, M20 - 5CP3150CSS, 5CP3150CSSG1	1
30	49776	AL	Cover, Bearing - 5CP3150CSS	1
	48224	AL	Cover, Bearing Blind - 5CP3150G1	1
32	46798	—	Cap, Oil Filler, Domed	1
33	14179	NBR	O-Ring, Oil Filler Cap - 70D	1
37	92241	PC	Gauge, Oil, Bubble w/Gasket - 80D	2
38	44428	NBR	Gasket, Flat, Oil Gauge - 80D	2
40	125824	STCP R	Screw, HHC, Sems (M6x16)	4
48	25625	STCP	Plug, Drain (1/4"x19BSP)	1
49	23170	NBR	O-Ring, Drain Plug - 70D	1
50	46940	AL	Cover, Rear	1
51	14044	NBR	O-Ring, Rear Cover	1
53	48617	AL	Crankcase	1
64	46746	CM	Pin, Crosshead	3
65	48458	BBNP	Rod, Plunger	3
70	46838	NBR	Seal, Oil, Crankcase - 70D	3
75	43900	S	Slinger, Barrier	3
88	45697	S	Washer, Keyhole (M18x10)	3
90	46884	CC	Plunger (M16x50)	3
98	46730	NBR	Washer, Seal - 90D	3
	48394	FPM	Washer, Seal - 90D	3
	◆ 48432	EPDM	Washer, Seal	3
99	† 48201	SS	Retainer, Plunger w/Stud (M6)	3
100	46749	PVDF	Retainer, Seal	3
106	43316	NBR	Seal, LPS w/S-Spg	3
	106660	FPM	Seal, LPS w/S-Spg	3
	◆ 49134	EPDM	Seal, LPS w/S-Spg	3
	76316	ST2	Seal, LPS w/S-Spg	3
120	46888	BB	Case, Seal (Press-in-style)	3
121	13978	NBR	O-Ring, Seal Case - 70D	3
	14329	FPM	O-Ring, Seal Case	3
	◆ 48904	EPDM	O-Ring, Seal Case	3
127	43319	SNG	V-Packing	6
	46287	HT	V-Packing	6
128	46618	NY	Adapter, Male	3
139	22179	BBCP	Plug, Inlet [1/2" NPT(M)]	1
163	17547	NBR	O-Ring, Seat - 85D	6
	11685	FPM	O-Ring, Seat - 85D	6
	◆ 46648	EPDM	O-Ring, Seat - 70D	6
164	45790	S	Seat	6
166	46429	S	Valve	6
167	43750	S	Spring	6
168	† 44565	PVDF	Retainer, Spring	6
172	17549	NBR	O-Ring, Valve Plug - 70D	6
	26996	FPM	O-Ring, Valve Plug - 70D	6
	◆ 49133	EPDM	O-Ring, Valve Plug	6
173	48365	D	Back-up-Ring, Valve Plug	6
174	45900	BB	Plug, Valve	6
185	46886	FBB	Manifold, Head	1
188	126513	STCP R	Screw, HSH (M8x70)	8
196	22187	BBCP	Plug, Discharge [3/8" NPT(M)]	1
255	30243	STZP	Mount, Direct	1
260	30611	STZP R	Mount, Rail, Assy (4.22")	1
	30613	STZP R	Mount, Rail, Assy (5.02")	1
	76513	STZP R	Mount, Rail, Assy (5.52")	1
283	34334	—	Kit, Oil Drain (3/8" x 24") (See Individual Data Sheet)	1
299	814843	FBB	Head, Complete w/NBR Seals and O-Rings	1
300	33629	NBR	Kit, Seal (Incls: 98,106,121,127,128) Standard	1
	31340	FPM*	Kit, Seal (Incls: 98,106,121,127,128) .0110	1
	◆ 31730	EPDM*	Kit, Seal (Incls: 98,106,121,127,128) .0220	1
	31665	HT	Kit, Seal (Incls: 98,106,121,127,128) .3000	1
	76556	STHT	Kit, Seal (Incls: 98,106,120,121,127,128) .3400	1

EXPLODED VIEW

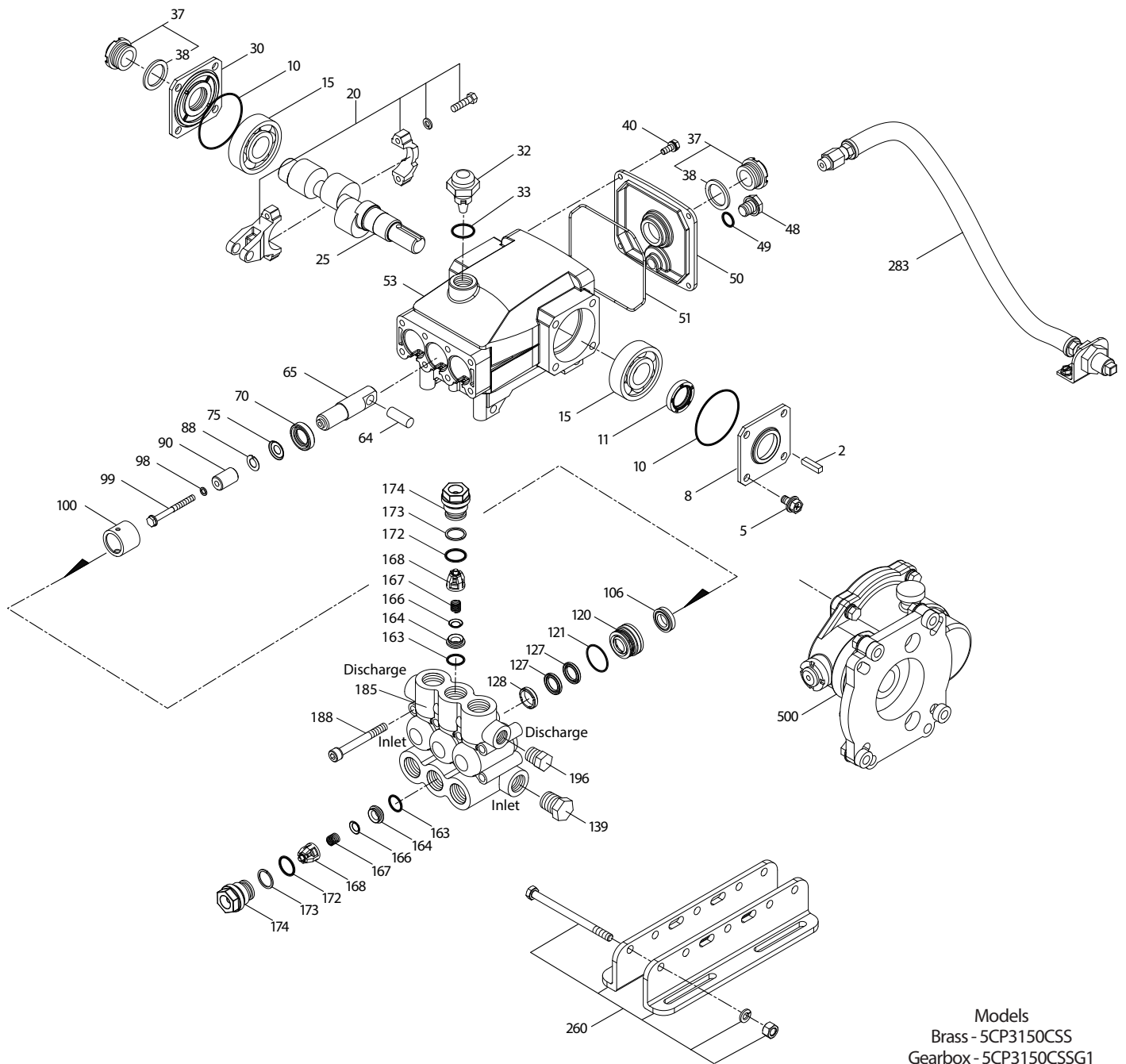

Models
 Brass - 5CP3150CSS
 Gearbox - 5CP3150CSSG1
 September 2019

5CP3150CSS			
5CP3150CSSG1		MATL	
310	33060	NBR Kit, Valve Preassembled (Incls: 163,164,166-168,172,173) Standard, .3000, .3400	2
	31345	FPM Kit, Valve Preassembled (Incls: 163,164,166-168,172,173) .0110	2
	◆ 31735	EPDM Kit, Valve Preassembled (Incls: 163,164,166-168,172,173) .0220	2
500	8076	— Gearbox (See Individual Data Sheet)	1
—	6107	— Oil, Bottle (21 oz.) ISO 68 Hydraulic (Fill to specified crankcase capacity prior to start-up)	1

Bold print part numbers are unique to a particular pump model. Italics are optional items. [] Date of latest production change. ◆ Silicone oil/grease required.
 † Production parts are different than repair parts. R Components comply with RoHS Directive. *Review individual parts in each kit for material code identification.

For additional technical information see www.catpumps.com/literature/tech-bulletins.

MATERIAL CODES (Not Part of Part Number): AL=Aluminum BB=Brass BBCP=Brass/Chrome Plated BBNP=Brass/Nickel Plated CC=Ceramic
 CM=Chrome-moly D=Acetal EPDM=Ethylene Propylene Diene Monomer FBB=Forged Brass FCM=Forged Chrome-moly FPM=Fluorocarbon
 HT=Hi-Temp (EPDM Alternative) NBR=Medium Nitrile (Buna-N) NY=Nylon PC=Polycarbonate PVDF=Polyvinylidene Fluoride S=304SS
 SS=316SS SNG=Special Blend (Buna) ST2=Special Blend PTFE Grey STHT=Special PTFE High Temp STL=Steel
 STCP=Steel/Chrome Plated STZP=Steel/Zinc Plated TNM=Special High Strength

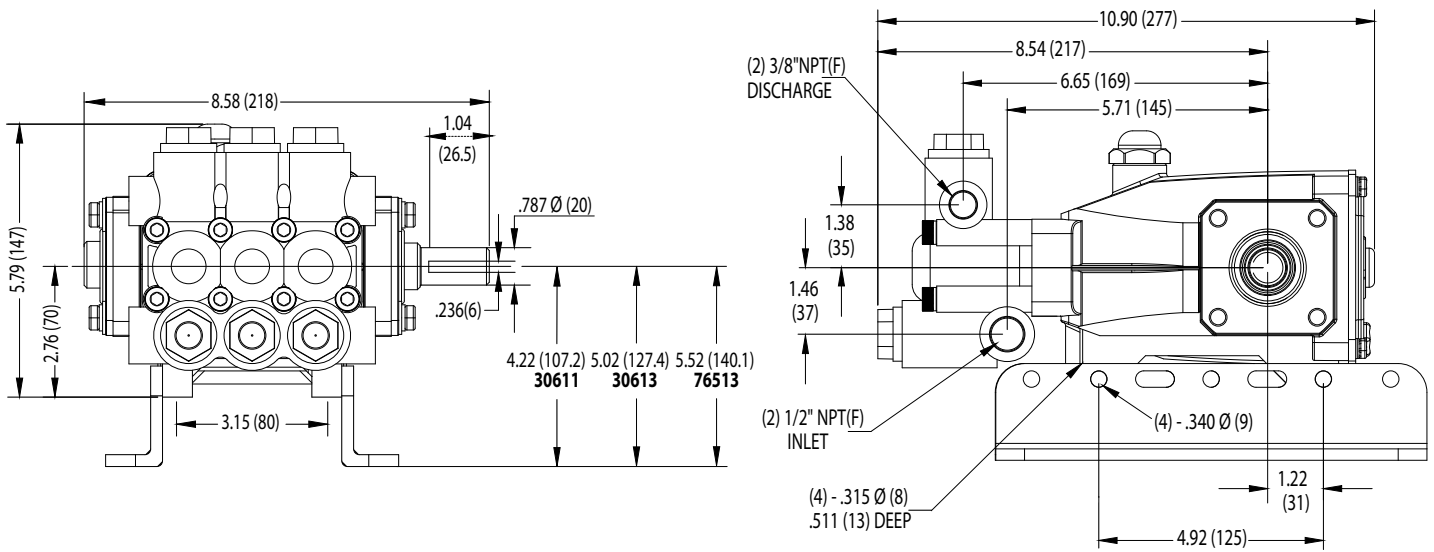

Model 5CP3150CSS

⚠ CAUTIONS AND WARNINGS

All high-pressure systems require a primary pressure regulating device (i.e. regulator, unloader) and a secondary pressure relief device (i.e. pop-off valve, relief valve). Failure to install such relief devices could result in personal injury or damage to pump or property. Cat Pumps does not assume any liability or responsibility for the operation of a customer's high-pressure system.

Read all CAUTIONS and WARNINGS before commencing service or operation of any high-pressure system. The CAUTIONS and WARNINGS are included in each Service Manual and with each Accessory Data sheet. CAUTIONS and WARNINGS can also be viewed online at www.catpumps.com/dynamic-literature/cautions-and-warnings or can be requested directly from Cat Pumps.

WARRANTY

View the Limited Warranty on-line at www.catpumps.com/literature/cat-pumps-limited-warranty