

# DATA SHEET

## DIRECT DRIVE PLUNGER PUMP

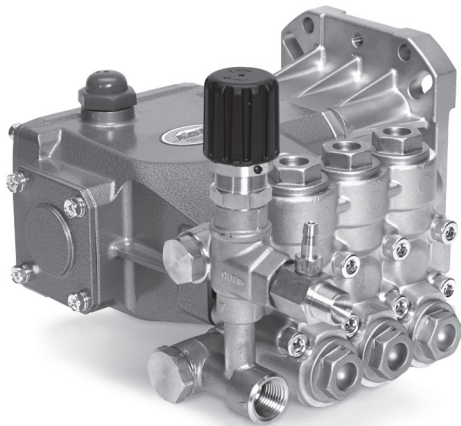

**Brass Model: 66DX50G11**



SPECIFICATIONS	U.S. Measure	Metric Measure
Flow	5.0 gpm	18.9 lpm
Pressure Range	100 – 3500 psi	6.9 – 241 bar
Pump RPM	3250 rpm	3250 rpm
Inlet Pressure Range	Flooded – 75 psi	Flooded – 5.1 bar
Max. Liquid Temperature	140° F	60° C
Bore	0.629"	16 mm
Stroke	0.421"	10.7 mm
Crankcase Capacity	18.0 oz.	0.55 l
Inlet Ports (2)	½" NPT(F)	½" NPT(F)
Discharge Ports (2)	⅜" NPT(F)	⅜" NPT(F)
Shaft Diameter (Hollow)	1.0"	25.4 mm
Engine Mounting Face	6.5"	6.5"
Weight	26.15 lbs.	11.9 kg
Dimensions	11.73 x 10.51 x 8.15"	298 x 267 x 207 mm

### FEATURES

- Triplex plunger design provides a smooth liquid flow.
- Special concentric, high-density, polished, solid ceramic plungers provide a true wear surface and extended seal life.
- Compact flange mount permits easy, direct mounting to most gas engines.\*
- Modular regulating unloader with built-in by-pass is standard for safety and pressure setting.\*\*
- Fixed chemical injector is standard and mounts directly onto unloader to provide cleaning flexibility.

\*Gas Mounting Flange: SAE J609, Flange B, Extension 4 (1"Ø), Shaft Length= 3 ¼", Pilot Ø= 5 ¾", BC. Ø= 6 ½", Thread ⅜"-16 UNC Tap.

\*\*Available without an unloader.

### ELECTRIC HORSEPOWER REQUIREMENTS

MODELS	FLOW		PRESSURE			RPM
			psi 2500	psi 3000	psi 3500	
	gpm	lpm	bar 172	bar 207	bar 241	
<b>66DX50G11</b>	5.0	18.9	8.6	10.3	12.0	3250

$$\text{DETERMINING THE PUMP R.P.M.} \quad \frac{\text{Rated gpm}}{\text{Rated rpm}} = \frac{\text{"Desired" gpm}}{\text{"Desired" rpm}}$$

$$\text{DETERMINING THE PROPER TORQUE} \quad T \text{ (FT-LBS)} = \frac{\text{gpm} \times \text{psi}}{\text{RPM}}$$

$$\text{DETERMINING THE REQUIRED H.P.} \quad \text{HP (Electric Brake)} = \frac{\text{gpm} \times \text{psi}}{1460}$$

Consult engine manufacture for actual torque available at required speed.

Refer to pump **Service Manual** for repair procedure and additional technical information.

## EXPLODED VIEW

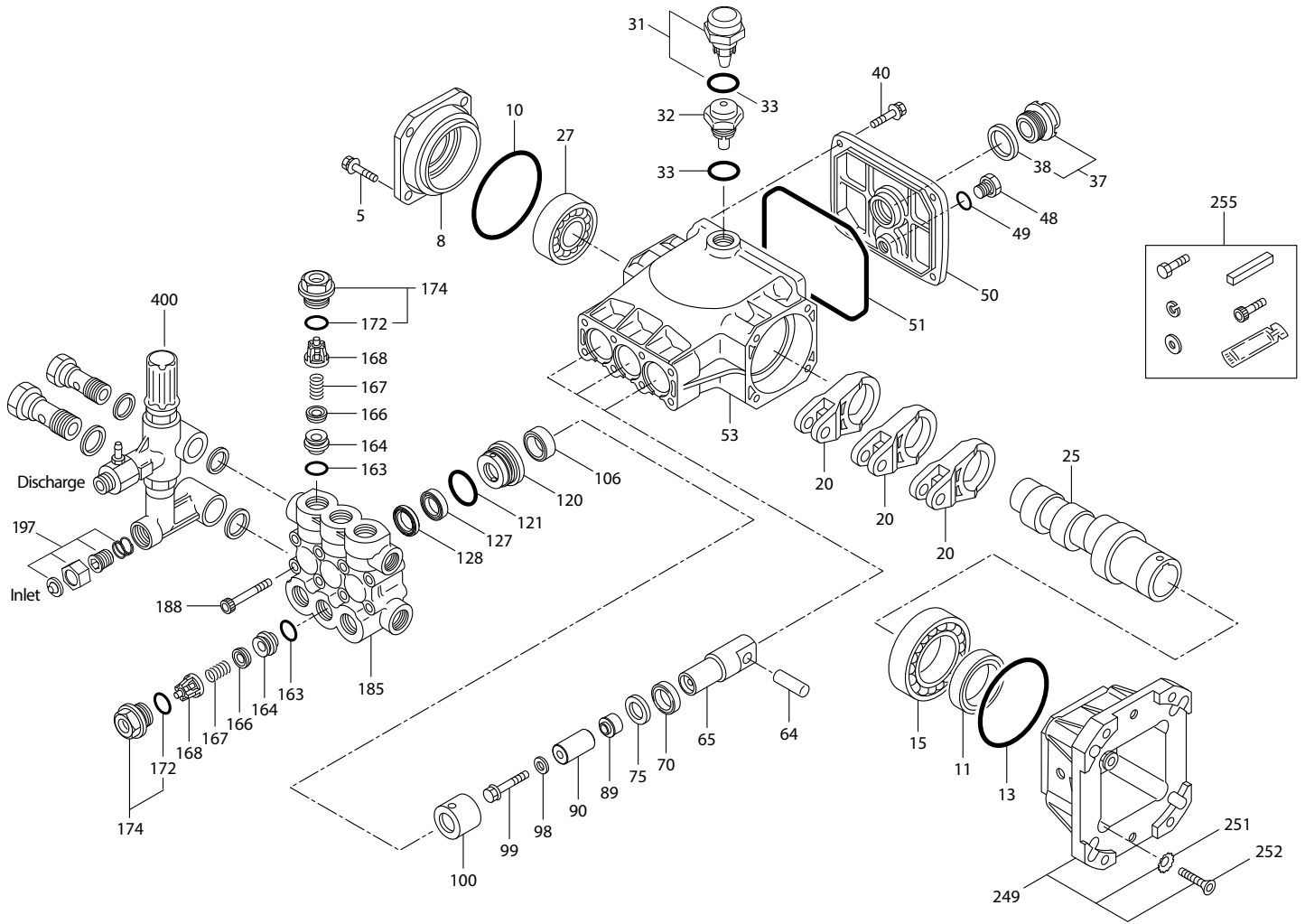

## PARTS LIST

ITEM	P/N	MATL	DESCRIPTION	QTY
5	125824	STCP R	Screw, HHC (M6 x 16) (See Tech Bulletin 074)	4
8	48259	AL	Cover, Bearing – 70D	1
10	14028	NBR	O-Ring, Bearing Cover – 70D	1
11	125351	NBR	Seal, Oil, Crankshaft	1
13	14037	NBR	O-Ring, Bearing Cover	1
15	146421	STL	Bearing, Ball, Inner	1
20	48843	TNM	Rod, Connecting (See Tech Bulletin 074)	3
25	134953	CM	Crankshaft, 10.7mm	1
27	14480	STL	Bearing, Ball, Outer	1
31	127409		Cap, Vented with O-Ring (Rain Cap)	1
32	46798	RTP	Cap, Domed, Oil Filler	1
33	14179	NBR	O-Ring, Oil Filler Cap – 70D	1
37	92241	PC	Gauge, Bubble Oil with Gasket – 80D (See Tech Bulletin 074)	1
38	44428	NBR	Gasket, Flat Flex., Oil Gauge – 80D	1
40	125824	STCP R	Screw, HHC (M6 x 16) (See Tech Bulletin 074)	4
48	25625	STCP	Plug, Drain [1/4" x 19BSP]	1
49	23170	NBR	O-Ring, Drain Plug – 70D	1
50	48862	AL	Cover, Rear	1
51	14048	NBR	O-Ring, Rear Cover	1
53	48830	AL	Crankcase	1
64	46404	CM	Pin, Crosshead	3
65	48845	BB	Rod, Plunger	3
70	48911	NBR	Seal, Oil, Crankcase	3
75	48754	NBR	Slinger, Barrier	3
89	134955	BB	Spacer	3
90	134351	CC	Plunger (M16 x 30)	3
98	46730	NBR	Washer, Seal, Plunger Retainer – 90D	3

ITEM	P/N	MATL	DESCRIPTION	QTY
99	49907	S	Retainer, Plunger (See Tech Bulletin 074)	3
100	48755	NY	Retainer, Seal	3
106	43316	NBR	Seal, LPS with S-Spring	3
120	134959	BB	Case, Seal	3
121	13980	NBR	O-Ring, Seal Case – 70D	3
127	134958	SNG	V-Packing	3
128	134957	NY	Adapter, Male	3
163	14181	NBR	O-Ring, Seat – 70D	6
164	134961	S	Seat	6
166	46429	S	Valve	6
167	134962	S	Spring	6
168	46583	NY	Retainer, Spring	6
172	17616	NBR	O-Ring, Valve Plug – 80D	6
174	48760	BB	Plug, Valve with NBR O-Ring (See Tech Bulletin 074)	6
185	134956	BB	Manifold, Discharge	1
188	126512	STCP R	Screw, HSH (M8 x 65) (See Tech Bulletin 074)	8
197	941517	BB	Assembly, Garden Hose (1/2" NPT(F))	1
249	48841	AL	Flanger, Adapter	1
251	126746	STCP R	Lockwasher, Conical (M8)	4
252	46403	STL	Screw, FH (M8 x 25)	4
255	30510	STZP	Assembly, Bolt Mount	1
300	76619	NBR	Kit, Seal (Includes: 98, 106, 121, 127, 128)	1
310	76631	NBR	Kit, Discharge Valve (Includes: 163, 164, 166, 167, 168, 172)	2
400	7860	BB	Unloader, Assembly with Fixed Injector	1
—	6107	—	Oil, Bottle (21 oz) ISO 68 Hydraulic (Fill to specified crankcase capacity prior to start-up)	1

*Italics are optional items. R Components comply with RoHS Directive.*

For additional technical information see [www.catpumps.com/literature/tech-bulletins](http://www.catpumps.com/literature/tech-bulletins).

MATERIAL CODES (Not Part of Part Number): AL=Aluminum BB=Brass CC=Ceramic CM=Chrome-moly D=Acetal NBR=Medium Nitrile (Buna-N) NY=Nylon PTFE=Pure Polytetrafluoroethylene RTP=Reinforced Composite S=304SS SNG=Special Blend (Buna) SS=316SS STCP=Steel/Chrome Plated STL=Steel STZP=Steel/Zinc Plated TNM=Special High Strength ZP=Zinc Plated

## MODEL 7860 UNLOADER WITH INJECTOR

SPECIFICATIONS	U.S.	Metric
Flow Range	3.0 – 5.0 gpm	7.6 – 18.9 lpm
PSI Range	700 – 4000 psi	50 – 275 bar
Inlet Port, Bottom	½" NPT(F)	½" NPT(F)
Discharge Port, Top	¾" NPT(M)	¾" NPT(M)
Weight	35.2 oz.	1.0 kg
Dimensions	4.65 x 170 x 6.75"	118 x 43 x 171 mm

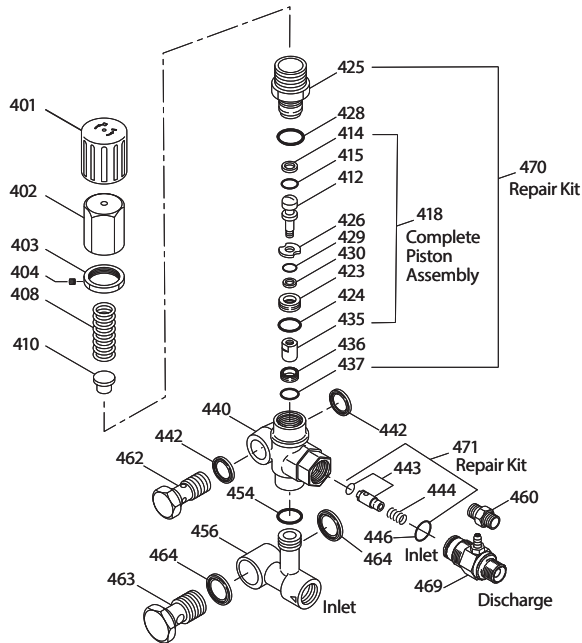

### PARTS LIST

ITEM	P/N	MATL	DESCRIPTION	QTY
401	49100	NY	Handle, Adjusting (Black)	1
402	49099	BB	Cap, Adjusting	1
403	125521	BB	Nut, Locking (M25 x 1)	1
404	88953	S	Screw, Set (M4 x 4)	1
408	45198	ZP R	Spring, Pressure	1
410	49101	STZP R	Retainer, Spring	1
412	49103	S	Stem, Piston	1
414	129638	PTFE	Back-up Ring, Piston Stem	1
415	49104	NBR	O-Ring, Piston Stem – 90D	1
418	—	BB	Assembly, Piston (Included in Repair Kit)	1
423	49105	BB	Retainer, Valve	1
424	49106	NBR	O-Ring, Valve Retainer – 70D	1
425	49102	BB	Retainer, Piston	1
426	49107	S	Washer	1
428	26133	NBR	O-Ring, Piston Retainer – 80D	1
429	22056	NBR	O-Ring, Valve Retainer – 70D	1
430	49123	D	Back-up Ring, Valve Retainer	1
435	49383	S	Valve/Ball Assembly	1
436	49384	S	Seat	1
437	13965	NBR	O-Ring, Seat – 70D	1
440	—	BB	Valve Body	1
442	49121	STL	Washer, Seal (¾")	2
443	49245	BB	Valve, Check with NBR O-Ring	1
444	117275	S	Spring, Check Valve	1
446	26133	NBR	O-Ring, Body – 80D	1
454	11346	NBR	O-Ring, Manifold – 70D	1
456	—	BB	Manifold	1
460	126974	BB	Fitting, Discharge [¾" NPT(M)]	1
462	49120	BB	Screw, Flo-Thru [¾" NPT(M)]	1
463	49117	BB	Screw, Flo-Thru [½" NPT(M)]	1
464	49118	STL	Washer, Seal (½")	2
468	31708	NBR	Kit, O-Ring (Includes: 414, 415, 424, 428 – 430, 437, 446, 454)	1
469	7367	BB	Injector, Chemical Fixed	1
470	31556	NBR	Kit, Repair (Includes: 418, 425, 428, 436, 437)	1
471	76185	NBR	Kit, Check Valve (Includes: 443, 444, 446)	1

*Italics are optional items.* R Components comply with RoHS Directive.

MATERIAL CODES (Not Part of Part Number): BB=Brass D=Acetal  
NBR=Medium Nitrile (Buna-N) NY=Nylon PTFE=Pure Polytetrafluoroethylene  
S=304SS STL=Steel STZP=Steel/Zinc Plated ZP=Zinc Plated

## MODEL 7367 FIXED CHEMICAL INJECTOR

SPECIFICATIONS	U.S.	Metric
Flow Range	3.0 – 5.0 gpm	11.4 – 18.9 lpm
Nozzle Orifice	2.1 mm	2.1 mm
Hose Barb – Extension	¼"	¼"
Tapped Barb	⅝" UNF	⅝" UNF
Inlet Port	M20	M20
Discharge Port	¾" NPT(M)	¾" NPT(M)
Weight	5.3 oz.	0.15 kg
Dimensions	2.0 x 1.0 x 1.75"	52 x 25 x 44 mm

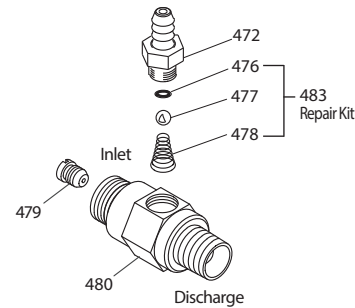

### PARTS LIST

ITEM	P/N	MATL	DESCRIPTION	QTY
472	—	BB	Barb	1
476	—	NBR	O-Ring, Barb – 70D	1
477	—	S	Ball	1
478	—	S	Spring	1
479	—	S	Orifice	1
480	—	BB	Body	1
483	76176	NBR	Kit, Repair (Includes: 476, 477, 478)	1

MATERIAL CODES (Not Part of Part Number):  
BB=Brass NBR=Medium Nitrile (Buna-N) S=304SS

### CHEMICAL INJECTOR PERFORMANCE CHART

Desired Pump Flow	Orifice Size	Maximum Injecting Pressure	Maximum Chemical Draw	Pressure Drop Across Injector At System Pressure (3500 psi)
5.0	2.1 mm	358 psi	76.8 oz./min	430 psi

Optimum performance of chemical injector occurs with a 35 ft. high pressure hose and a minimum ¾" I.D. The type of hose, extended lengths, reduced I.D. and fittings may create back pressures in excess of the low pressure nozzle rating and prevent the injector from drawing chemical. **Deduct hose friction loss from above low psi nozzle. Contact Cat Pumps for assistance with other options.**

**Note:** Deduct the pressure drop shown in the performance chart from your desired system pressure to arrive at the maximum high pressure nozzle rating. This is essential to avoid over-pressurizing the pump.

### UNLOADER TYPE:

A modular regulating unloader with chemical injector comes with each 66DX pump to provide system pressure regulation, pump protection, and metered chemical application.

### OPERATION:

Purge pump prior to operation by allowing liquid to flow through the pump without discharge restriction. Removing trapped air will assure full system pressure can be obtained. Install a pressure gauge close to the manifold head to assist in setting system pressure and to monitor system pressure. Setting and adjusting the unloader pressure must be done with the system turned on. Start the system with the unloader backed off to the lowest pressure setting (counterclockwise direction). Squeeze the trigger and read the pressure on the gauge at the pump. Do not read pressure at the gun or nozzle. If more pressure is desired, release the trigger, turn adjusting cap one quarter turn in a clockwise direction. Squeeze the trigger and read the pressure. Repeat this process until the desired system pressure is reached. Thread locking nut up to adjusting cap and tighten set screw. All high-pressure systems should have a secondary relief valve.

Set secondary relief valve 200 – 300 psi above the unloader setting.

**NOTE:** Pressure is not set at the factory.

### SERVICE:

The unloader should be serviced on the same schedule as the seals in the pump. Refer to 66DX Service Manual for start-up, servicing of seals and valves, torque requirements and Diagnosis/Maintenance chart.

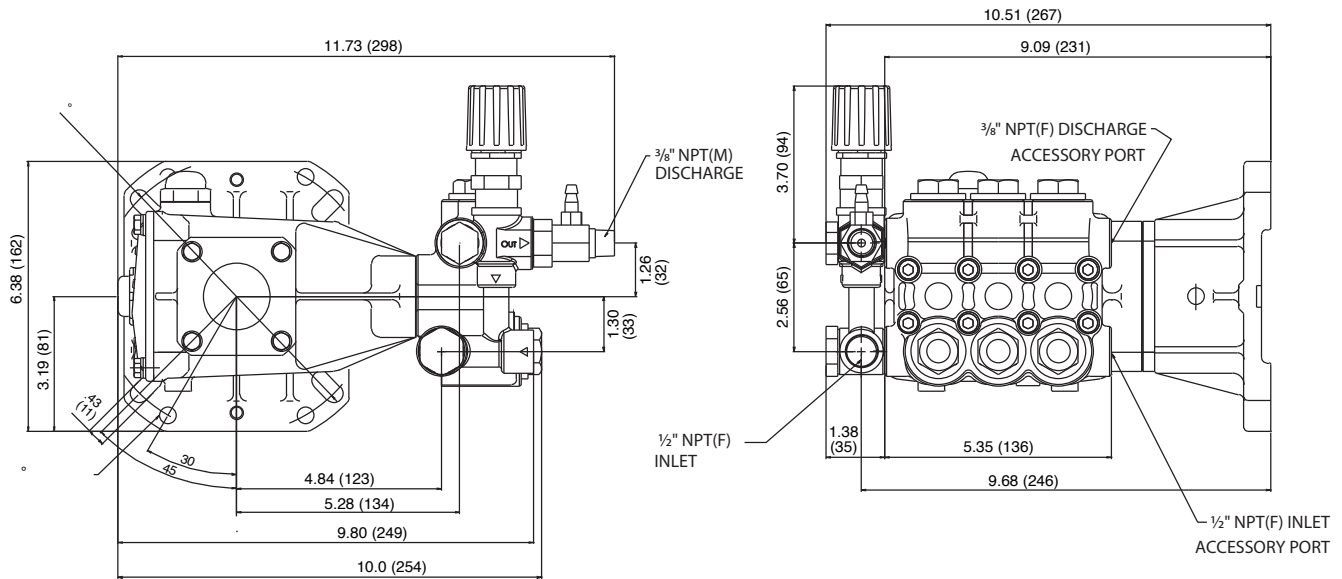

**⚠ CAUTIONS AND WARNINGS**

All high-pressure systems require a primary pressure regulating device (i.e. regulator, unloader) and a secondary pressure relief device (i.e. pop-off valve, relief valve). Failure to install such relief devices could result in personal injury or damage to pump or property. Cat Pumps does not assume any liability or responsibility for the operation of a customer's high-pressure system.

Read all CAUTIONS and WARNINGS before commencing service or operation of any high-pressure system. The CAUTIONS and WARNINGS are included in each Service Manual and with each Accessory Data sheet. CAUTIONS and WARNINGS can also be viewed online at [www.catpumps.com/dynamic-literature/cautions-and-warnings](http://www.catpumps.com/dynamic-literature/cautions-and-warnings) or can be requested directly from Cat Pumps.

**WARRANTY**

View the Limited Warranty on-line at [www.catpumps.com/literature/cat-pumps-limited-warranty](http://www.catpumps.com/literature/cat-pumps-limited-warranty)