

DATA SHEET

15 FRAME PLUNGER PUMPS

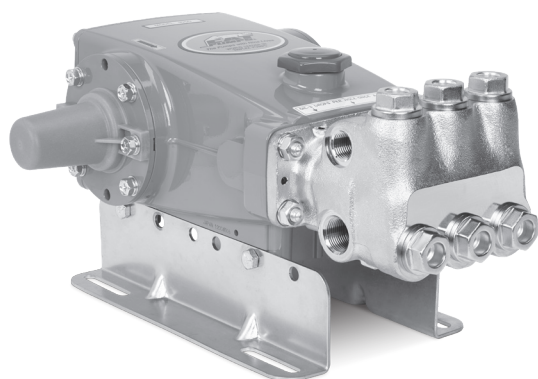

Brass Model: 1050



(Shaft protector included rails sold separately)

FEATURES

- Triplex design delivers high efficiency and low pulsation.
- Pre-set low-pressure seals provide secondary protection against external leaks and require no packing adjustments.
- Belt driven option provides precision flow settings.
- Compact direct-drive with bell housing and flexible coupler assembly. NEMA or IEC electric motor or hydraulic options available.
- Standard NBR seals with alternative options for temperature and chemical compatibility.

COMMON SPECIFICATIONS

	U.S.	Metric
Bore	0.945"	24 mm
Stroke	1.181"	30 mm
Crankcase Capacity	42 oz.	1.26 l
Inlet Ports (2)	3/4" NPT(F)	3/4" NPT(F)
Discharge Ports (2)	1/2" NPT(F)	1/2" NPT(F)
Pulley Mounting	Either Side	Either Side
Shaft Diameter	1.181"	30 mm
Weight	44 lbs.	20 kg
Dimensions	16.28 x 12.99 x 6.45"	414 x 330 x 164 mm

SPECIFICATIONS

	U.S.	Metric
Flow	10 gpm	38 lpm
Pressure Range	100 – 2200 psi	6.9 – 152 bar
Pump RPM*	958 rpm	958 rpm
Inlet Pressure Range	-5 – 60 psi	-0.35 – 4.1 bar
Max. Liquid Temperature (NBR)	160°F	71°C

Alternate seals available for higher temperatures up to 200° F.

ALTERNATE SPECIFICATIONS

	U.S.	Metric
Flow	12.3 gpm	46.6 lpm
Pressure Range	100 – 1800 psi	6.9 – 124 bar
Pump RPM*	1180 rpm	1180 rpm
Inlet Pressure Range	20 – 60 psi	1.4 – 4.1 bar
Max. Liquid Temperature	100° F	38° C

*Pump minimum is 100 RPM.

ALTERNATIVE SEAL CONFIGURATION

MATERIAL	SUFFIX CODE	MAXIMUM TEMPERATURE	
NBR	—	160° F	(71° C)
FPM	.0110	180° F	(82° C)
EPDM	.0220	160° F	(71° C)
IPFE	.0770	200° F	(93° C)
HT	.3000	180° F	(82° C)
STHT	.3400	190° F	(88° C)

See **Tech Bulletin 002** for inlet conditions and RPM at high temperature.

$$\text{DETERMINING THE PUMP R.P.M.} \quad \frac{\text{Rated gpm}}{\text{Rated rpm}} = \frac{\text{"Desired" gpm}}{\text{"Desired" rpm}}$$

$$\text{DETERMINING THE REQUIRED H.P.} \quad \frac{\text{HP (Electric Brake)}}{1460} = \frac{\text{gpm x psi}}{1460}$$

$$\text{DETERMINING MOTOR PULLEY SIZE} \quad \frac{\text{Motor Pulley O.D.}}{\text{Pump rpm}} = \frac{\text{Pump Pulley O.D.}}{\text{Motor rpm}}$$

Refer to pump **Service Manual** for repair procedure and additional technical information.

PARTS LIST

ITEM	PN	MATL	DESCRIPTION	QTY
5	126540	STCP R	Screw, HHC Sems (M8 x 20) (See Tech Bulletin 074, 128)	8
8	134805	ALE	Cover, Bearing (See Tech Bulletin 118, 128)	2
9	855043	FBR	Shim, Split, Bearing Cover 2-Piece (See Tech Bulletin 128)	2/4
10	11340	NBR	O-Ring, Bearing Cover – 70D	2
11	43495	NBR	Seal, Oil, Crankshaft	2
12	855044	S	Shim, Split, Bearing Cover 2-Piece (See Tech Bulletin 128)	0/4
15	39060	STL	Bearing, Roller	2
20	48600	TNM	Rod, Connecting Assembly [10/01] (See Tech Bulletin 074)	3
25	43494	FCM	Crankshaft, Dual End (M30)	1
32	43211	ABS	Cap, Oil Filler	1
33	14177	NBR	O-Ring, Filler Cap – 70D	1
37	92241	PC	Gauge, Oil, Bubble with Gasket – 80D (See Tech Bulletin 074)	1
38	44428	NBR	Gasket, Flat, Oil Gauge – 80D	1
40	126541	STCP R	Screw, HHC Sems (M6 x 20) (See Tech Bulletin 074)	4
48	25625	STCP	Plug, Drain (1/4" x 19BSP)	1
49	23170	NBR	O-Ring, Drain Plug – 70D	1
50	133576	ALE	Cover, Rear (See Tech Bulletin 118)	1
51	44834	NBR	O-Ring, Rear Cover – 70D	1
53	134836	ALE	Crankcase with Guide Pins (Includes: 54, 55) (See Tech Bulletin 118, 128)	1
54	27488	S	Pin, Guide	2
55	126545	STCP R	Stud, Manifold (M10 x 45) (See Tech Bulletin 128)	4
56	44664	POP	Pan, Oil	1
64	43507	CM	Pin, Crosshead	3
65	43501	SZZ	Rod, Plunger	3
69	126592	STCP R	Washer, Oil Seal	3
70	43500	NBR	Seal, Oil, Crankcase – 80D	3
75	43506	S	Slinger, Barrier	3
88	45675	S	Washer, Keyhole	3
89	43553	BB	Collar, Spacer	3
90	43552	CC	Plunger (M24 x 77)	3
96	43235	PTFE	Back-up Ring, Plunger Retainer	3
97	17399	NBR	O-Ring, Plunger Retainer – 80D	3
98	45891	CU	Gasket, Plunger Retainer	3
99	104360	S	Retainer, Plunger (M6) (See Tech Bulletin 074)	3
100	855001	POP	Retainer, Seal 2-Piece [07/05] (See Tech Bulletin 098)	3
101	43554	—	Wick, Long Tab	3
106	44035	NBR	Seal, LPS with SS-Spring	3
120	49290	BB	Case, Seal [07/05]	3
121	14762	NBR	O-Ring, Seal Case – 70D	3
126	43558	BB	Adapter, Female	3
127	43559	SNG	V-Packing	6
128	43560	BB	Adapter, Male	3
139	20326	BBCP	Plug, Inlet [3/4" NPT(F)]	1
162	43248	PTFE	Back-up Ring, Valve Seat	6
163	43249	NBR	O-Ring, Seat – 80D	6
164	44718	S	Seat	6
166	43721	S	Valve	6
167	43751	S	Spring, Valve	6
168	44564	PVDF	Retainer, Spring	6
172	17617	NBR	O-Ring, Valve Plug – 90D	6
174	43851	BBCP	Plug, Valve (See Tech Bulletin 074)	6
185	46704	BBCP	Head, Manifold [9/00]	1
192	126231	STCP R	Lockwasher (M10)	4
194	126522	STCP R	Nut, Hex (M10)	4
250	855046	NY	Protector, Shaft with Two Screws (See Tech Bulletin 128)	1

[] Date of latest production change.

R components comply with RoHS Directive.

For additional technical information see www.catpumps.com/literature/tech-bulletins.

MATERIAL CODES (Not Part of Part Number): ABS=ABS Plastic ALE= Aluminum Epoxy BB=Brass BBCP=Brass/Chrome Plated CC=Ceramic
 CM=Chrome-moly CU=Copper FBR=Fiber FCM=Forged Chrome-moly NBR=Medium Nitrile (Buna-N) NY=Nylon PC=Polycarbonate
 PE=Polyethylene POP=Polypropylene PTFE=Pure Polytetrafluoroethylene PVDF=Polyvinylidene Fluoride S=304SS SNG=SpecialBlend (Buna)
 STCP=Steel/Chrome Plated STL=Steel STZP=Steel/Zinc Plated SZZ=304SS/Zamak TNM=Special High Strength

EXPLODED VIEW

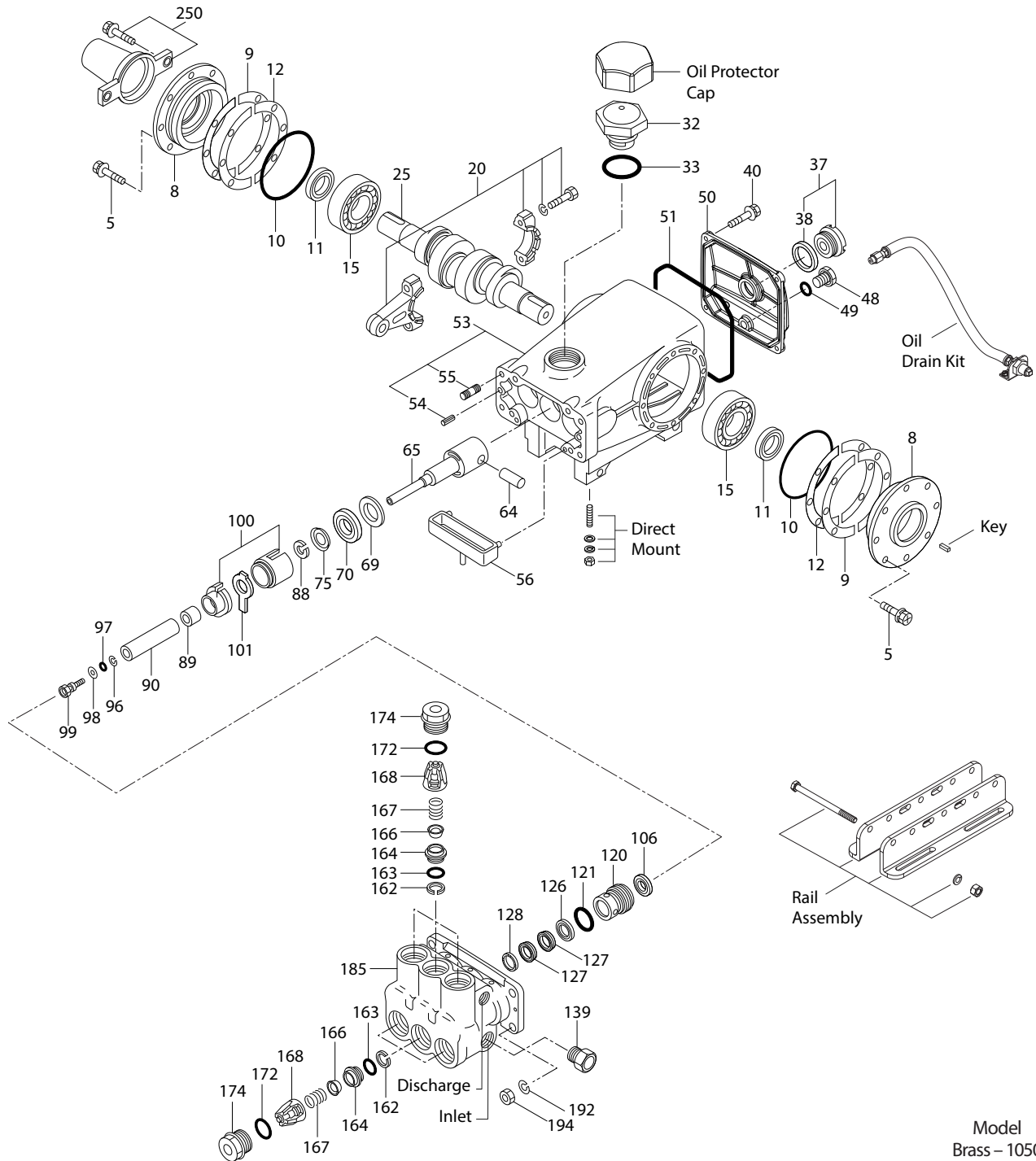

Model
Brass – 1050
September 2020

OPTIONAL PARTS AND ACCESSORIES

PART	DESCRIPTION	QTY
30067	Key (M8 x 7.5 x 25)	1
30661	Mount, Assembly (Includes: 30613, 30206, 30059, 30067, 855046)	1
30264	Kit, Direct Mount	1
30613	Assembly, Rail (See Dimensional Drawing)	1
990550	Assembly, Rail for Diesel/Gas (See Dimensional Drawing)	1
76513	Assembly, Rail (See Dimensional Drawing)	1
828710	Protector, Oil Cap with Foam Gasket	1
30059	Hub, "H" 30mm	1
34334	Kit, Oil Drain (3/8" x 24") (See Individual Data Sheet)	1

SERVICE PARTS

PART	DESCRIPTION	QTY
30913	Seal Kit – Standard NBR	1
34920	Valve Kit – Standard NBR	2
6107	Oil, Bottle (21 oz.) ISO 68 Hydraulic	2
6124	Gasket, Liquid (3 oz.)	1
814560	Head, Complete with NBR Seals and O-rings	1
30696	Pliers, Reverse	1
33006	Socket, Seal Case (1/2" Drive)	1

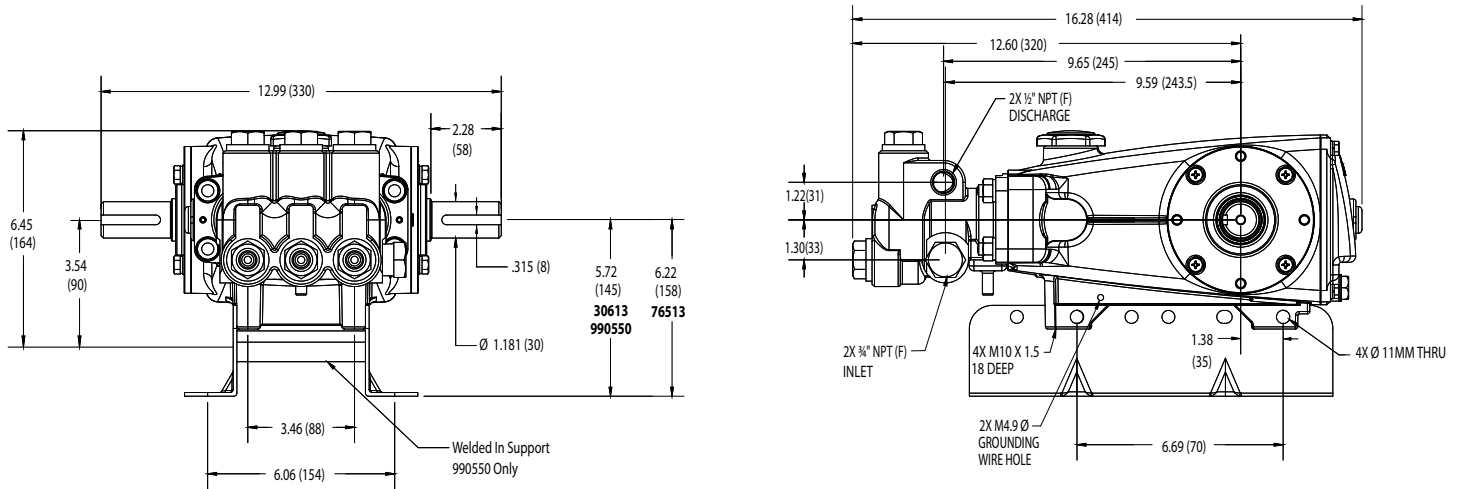

SEAL KITS One (1) seal kit required per pump

PUMP MODEL	NBR (STD)	FPM (.0110)	EPDM (.0220) ◆	IPFE (.0770)	STHT (.3400)
1050	30913	30986	33913	76913	76062

ITEM (Included in Seal Kits)						DESCRIPTION	QTY
97	17399	14160	46204	701715	17399	O-Ring, Plunger Retainer	3
100	855001	855001	855001	855001	855001	Retainer, Seal 2-Piece	3
106	44035	44388	46208	703243	76035	Seal, LPS with SS-Spring	3
121	14762	11737	46205	701851	14762	O-Ring, Seal Case	3
127	43559	103692	103692	103692	103692	V-Packing	6

◆ Silicone oil/grease required

VALVE KITS Two (2) valve kits required per pump

PUMP MODEL	NBR (STD)			
	STHT (.3400)	FPM (.0110)	EPDM (.0220) ◆	IPFE (.0770)
1050	34920	31256	31253	76385

ITEM (Included in Seal Kits)					DESCRIPTION	QTY
162	43248	43248	43248	43248	Back-up Ring, Valve Seat	3
163	43249	44383	44206	701852	O-Ring, Valve Seat	3
164	44718	44718	44718	44037	Seat	3
166	43721	43721	43721	48793	Valve	3
167	43751	43751	43751	44039	Spring	3
168	44564	44564	44564	44564	Retainer, Spring	3
172	17617	11691	46207	701853	O-Ring, Valve Plug	3

◆ Silicone oil/grease required

⚠ CAUTIONS AND WARNINGS

All high-pressure systems require a primary pressure regulating device (i.e. regulator, unloader) and a secondary pressure relief device (i.e. pop-off valve, relief valve). Failure to install such relief devices could result in personal injury or damage to pump or property. Cat Pumps does not assume any liability or responsibility for the operation of a customer's high-pressure system.

Read all CAUTIONS and WARNINGS before commencing service or operation of any high-pressure system. The CAUTIONS and WARNINGS are included in each Service Manual and with each Accessory Data sheet. CAUTIONS and WARNINGS can also be viewed online at www.catpumps.com/dynamic-literature/cautions-and-warnings or can be requested directly from Cat Pumps.

WARRANTY

View the Limited Warranty on-line at www.catpumps.com/literature/cat-pumps-limited-warranty