

TECH BULLETIN 135



Product changes to crankcase and bearing covers for all 25 and 28 Frame plunger and piston pumps

Changes have been made to the crankcase and mounting hardware to better support the weight of direct-drive hydraulic bell housings. This affects all 25 and 28 frame plunger pumps with date codes/serial numbers after July 2020.

Improvements:

- Crankcase bell housing mounting bolt holes number increased from four (4) to eight (8) to better distribute weight of hydraulic motor on crankcase.
- Bell housing mounting bolt quantity changed from four (4) M8 to eight (8) M8 bolts.

Functionality Changes:

- Crankcase has eight (8) tapped holes on each side for hydraulic bell house mounting.
- Bearing cover has eight (8) through holes, but only supplied with four (4) M8 bolts.
- No change to the shaft protector.

New Crankcase Style

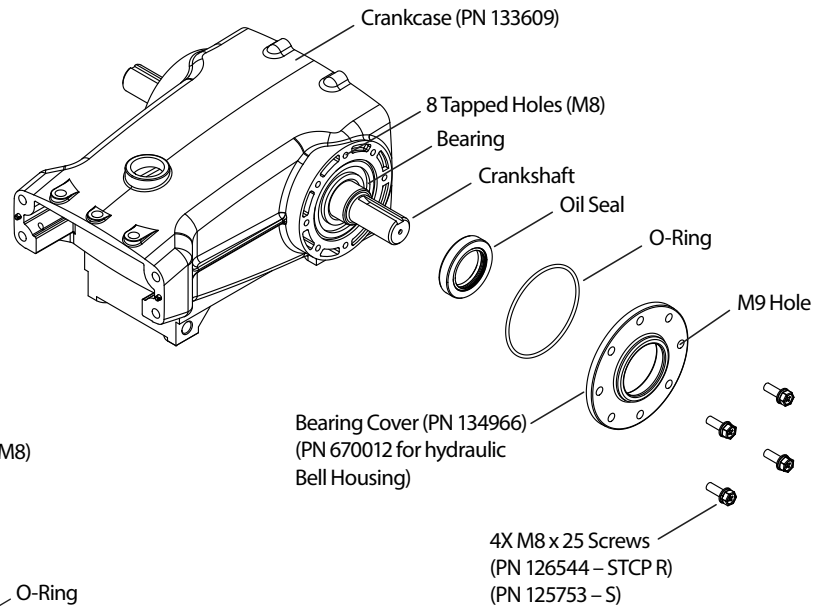

Old Crankcase Style

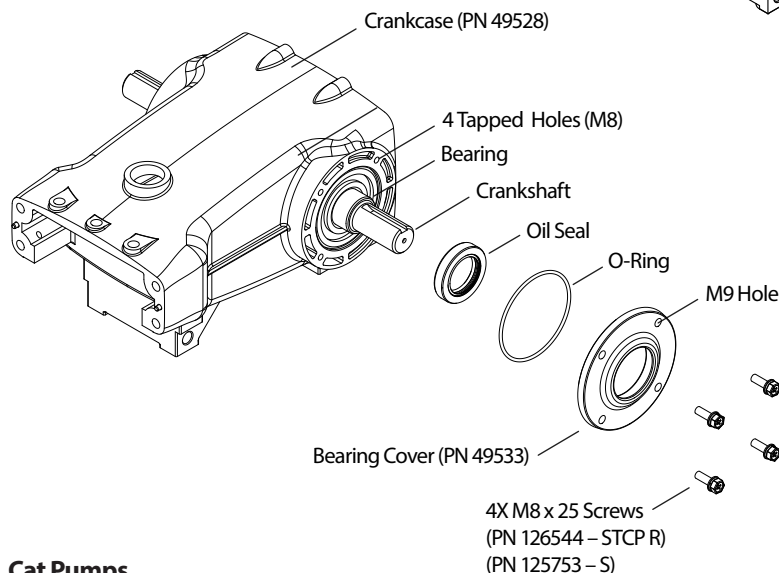

Cat Pumps

Technical Services Department

99TCH135 Rev A 9/20