

## Direct-Drive Plunger Pumps

Models **6DX35G11**  
**6DX40G11**

### FEATURES

- Triplex plunger design provides a smooth liquid flow.
- Specially formulated Hi-Pressure V-Packings and concentric, polished ceramic plungers assure maximum seal life.
- Built-in flange mount for easy, direct mounting to most gas engines. Eliminates the need for pulleys, belts, gearboxes.
- Modular Regulating Unloader with built-in by-pass and flow-thru screws is standard to assure system pressure control and pump protection.
- Chemical Injector is standard for cleaning flexibility.

<b>DETERMINING THE PUMP R.P.M.</b>	$\frac{\text{Rated G.P.M.}}{\text{Rated R.P.M.}}$	=	$\frac{\text{"Desired" G.P.M.}}{\text{"Desired" R.P.M.}}$
<b>DETERMINING THE REQUIRED H.P.</b>	$\frac{\text{GPM} \times \text{PSI}}{1460}$	=	Electric Brake H.P. Required
<b>DETERMINING MOTOR PULLEY SIZE</b>	$\frac{\text{Motor Pulley O.D.}}{\text{Pump R.P.M.}}$	=	$\frac{\text{Pump Pulley O.D.}}{\text{Motor R.P.M.}}$

Note: Consult engine manufacturer when using gas or diesel engine.  
Refer to pump Service Manual for important Inlet Condition Check-List,  
Start-up Procedure, Tech Bulletins and Pump Maintenance information.

### SPECIFICATIONS

	U.S. Measure	Metric Measure
<b>MODEL 6DX35G11</b>		
Flow .....	3.5 GPM	(13.2 L/M)
Pressure Range .....	100 to 4000 PSI	(7 to 275 BAR)
Stroke.....	0.394"	(10 mm)
<b>MODEL 6DX40G11</b>		
Flow.....	4.0 GPM	(15.0 L/M)
Pressure Range .....	100 to 4000 PSI	(7 to 275 BAR)
Stroke.....	0.449"	(11.4 mm)

### COMMON PUMP SPECIFICATIONS

Max. RPM .....	3400 RPM	(3400 RPM)
Engine Mounting Face.....	6.5"	(6.5")
Max. Inlet Pressure .....	Flooded to 75 PSI	(Flooded to 5.25 BAR)
Bore.....	0.551"	(14 mm)
Shaft Diameter (Hollow).....	1"	(25.4 mm)
Max. Liquid Temperature .....	100°F	(40°C)
Crankcase Capacity .....	18.6 oz.	(0.55 L)
Inlet Ports (2).....	1/2" NPTF	(1/2" NPTF)
Discharge Ports (2).....	3/8" NPTF	(3/8" NPTF)
Weight.....	26.15 lbs.	(11.9 kg)
Dimensions (Pump Only) .....	10.20 x 9.96 x 6.38"	(259 x 253 x 162 mm)

### HORSEPOWER REQUIREMENTS

MODEL	FLOW		PRESSURE			RPM
			PSI 2500	PSI 3200	PSI 4000	
	U.S. GPM	L/M	BAR 175	BAR 220	BAR 275	
<b>6DX35G11</b>	3.5	13.2	6.0	7.7	9.6	3400
<b>6DX40G11</b>	4.0	15.0	6.9	8.8	11.0	3400

*"Customer confidence is our greatest asset"*

# EXPLODED VIEW

January 2001

# 6DX PLUNGER PUMP MODELS

With Unloader/Injector - 6DX35G1I, 6DX40G1I  
Without Unloader - 6DX35GG1, 6DX40GG1

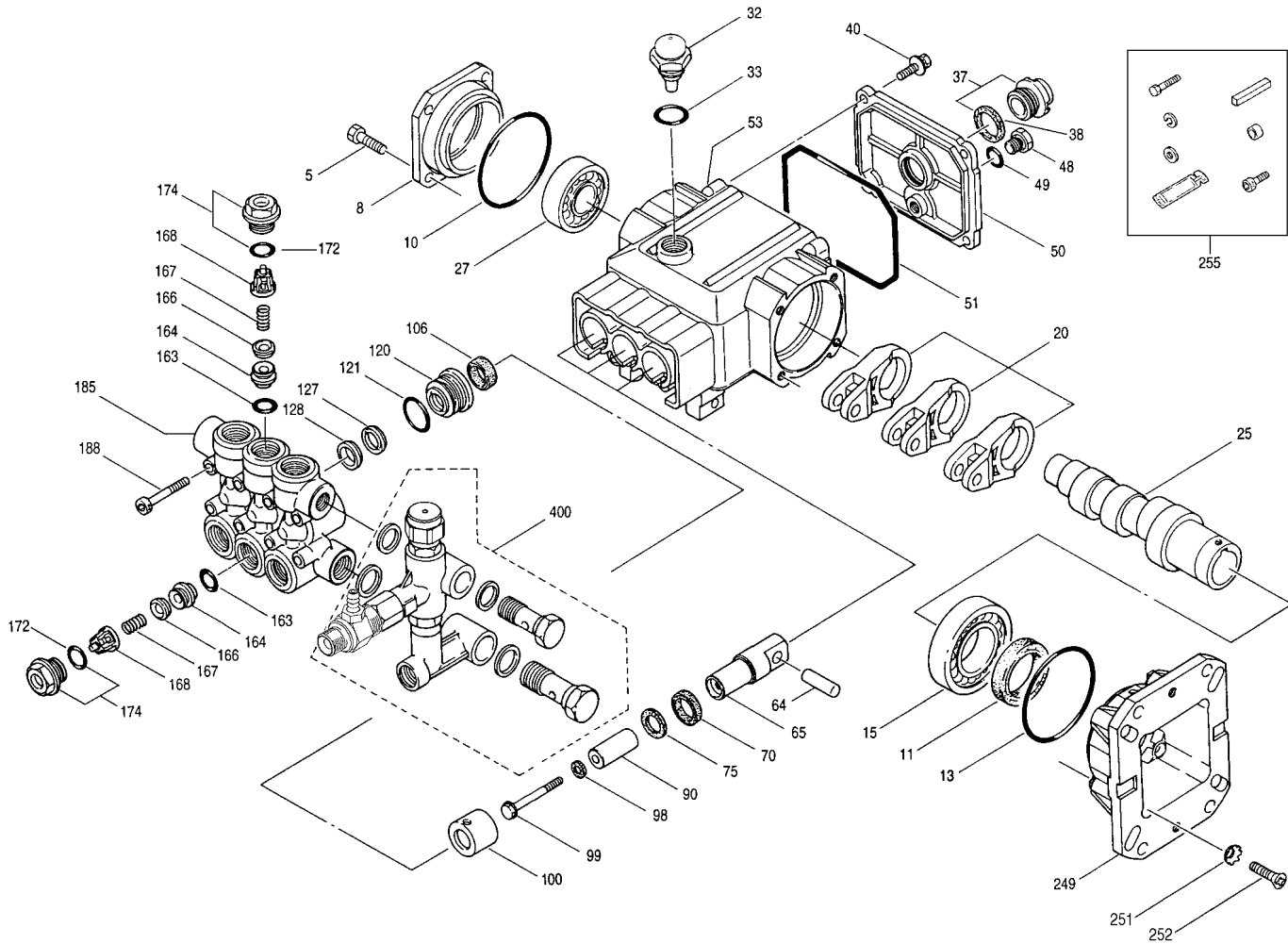

## PARTS LIST

ITEM	P/N	MATL	DESCRIPTION	QTY	ITEM	P/N	MATL	DESCRIPTION	QTY
5	92521	STZP	Screw (M8x20)	4	106	45188	NBR	Seal, LPS w/S-Spg	3
8	46461	AL	Cover, Bearing	1	120	48759	BB	Case, Seal	3
10	14037	NBR	O-Ring, Bearing Cover	1	121	13980	NBR	O-Ring, Seal Case	3
11	46419	NBR	Seal, Oil, Crankshaft	1	127	48758	SNG	V-Packing	3
13	14037	NBR	O-Ring, Bearing Cover	1	128	48757	NY	Adapter, Male	3
15	146421	STL	Bearing, Ball - Inner	1	163	17547	NBR	O-Ring, Seat - 85D	6
20	48750	ZZ	Rod, Connecting	3	164	46658	S	Seat	6
25	48748	CM	Crankshaft (11.4mm)	1	166	46429	S	Valve	6
	48781	CM	Crankshaft (10.0 mm)	1	167	43750	S	Spring	6
27	14480	STL	Bearing, Ball - Outer	1	168	46583	NY	Retainer, Spring	6
32	48787	—	Cap, Domed, Oil Filler	1	172	17616	NBR	O-Ring, Valve Plug - 80D	6
33	14179	NBR	O-Ring, Filler Cap - 70D	1	174	48760	BB	Plug, Valve w/O-Ring	6
37	92241	—	Gauge, Oil Bubble w/Gasket	1	185	48756	BB	Head, Manifold	1
38	44428	NBR	Gasket, Flat, Oil Gauge - 80D	1	188	87870	STZP	Screw, HSH (M8x65)	8
40	92519	STZP	Screw, Sems (M6x16)	4	249	46679	AL	Flange Mount	1
48	25625	STCP	Plug, Drain (1/4"x19BSP)	1	251	46123	STZP	Lockwasher, Conical (M8)	4
49	23170	NBR	O-Ring, Drain Plug - 70D	1	252	46403	STZP	Screw, FH (M8x25)	4
50	46379	AL	Cover, Crankcase	1	255	30519	STZP	Kit, Bolt Mount	4
51	14048	NBR	O-Ring, Crankcase Cover	1	34100	STZP	Screw (3/8-16x1-3/8")	4	
● 53	48746	AL	Crankcase	1 ●	30921	STZP	Lockwasher, Split (3/8")	4	
64	46404	CM	Pin, Crosshead	3	30980	STZP	Washer, Flat (3/8")	4	
65	48753	BBCP	Rod, Plunger	3	6106	—	Antiseize Lubricant	1	
70	29257	NBR	Seal, Oil, Crankcase	3	45217	STL	Key (1/4"x1/4"x2-1/2") HD	1	
75	48754	NBR	Slinger, Barrier	3	34042	AL	Spacer	4	
90	48752	CC	Plunger (M14x47)	3	87788	STZP	Screw, Set (M5x8)	1	
98	46730	NBR	Washer Seal, Plunger Retainer	3	300	34262	NBR	Kit, Seal [Incls: 98,106,121,127,128]	1
99	48201	SS	Retainer, Plunger	3	310	34260	NBR	Kit, Valve [Incls: 163,164,166,167,168,172]	2
100	48755	NY	Retainer, Seal	3	400	7645	BB	Unloader Assembly w/Chemical Injector	1

● Industrial discount. *Italics are optional items.*

See Tech Bulletins 24, 60, 74 and 83 for additional information.

MATERIAL CODES (Not Part of Part Number): AL=Aluminum BB=Brass BBCP=Brass/Chrome Plated CC=Ceramic CM=Chrome-moly

NBR=Medium Nitrile (Buna-N) NY=Nylon S=304SS SNG=Special Blend (Buna) SS=316SS STCP=Steel/Chrome Plated STL=Steel STZP=Steel/Zinc Plated ZZ=Zamak

## 7645 UNLOADER

Specifications	U.S. Measure	Metric Measure
GPM.....	2.0-5.0 GPM	(7.6-19 L/M)
PSI.....	700-4000 PSI	(50-275 BAR)
Inlet Port - Side.....	1/2" NPTF	(1/2" NPTF)
Discharge Port - Front.....	3/8" NPTF	(3/8" NPTF)
Weight.....	32.8 oz.	(0.93 kg)
Dimensions.....	4.5 x 2.0 x 6.50"	(114 x 51 x 165 mm)

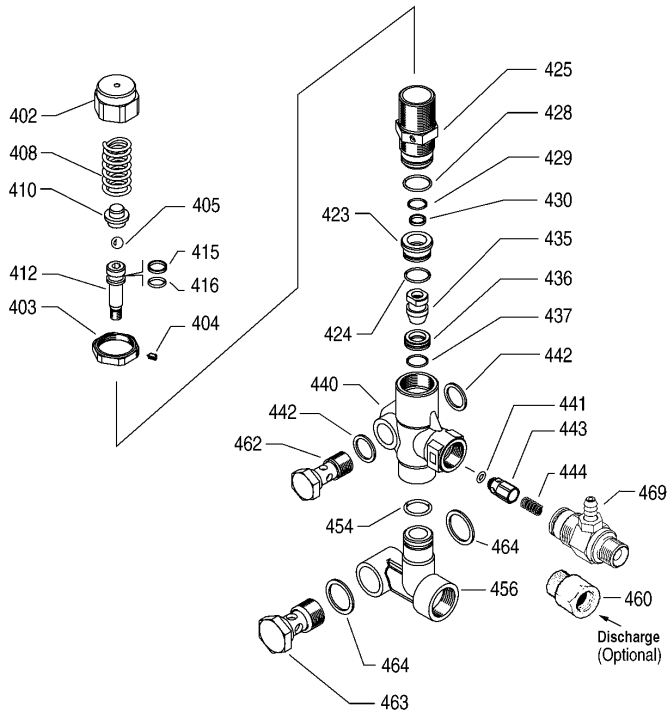

### PARTS LIST

ITEM	P/N	MATL	DESCRIPTION	QTY.
400	7645	BB	Unloader Assembly w/Chemical Injector	1
402	34585	BB	Cap, Adjusting	1
403	34583	BB	Nut, Locking (M27x1)	1
404	33061	STZP	Screw, Set (M4x4)	1
405	32289	SSSS	Ball (11/32")	1
408	34587	S	Spring	1
410	34574	BB	Retainer, Spring	1
412	34571	SS	*Stem, Piston Assy	1
415	—	PTFE	Guide Ring, Piston Stem	1
416	—	NBR	O-Ring, Piston Stem	1
423	34582	BB	Spacer	1
424	33043	NBR	O-Ring, Spacer	1
425	—	BB	Retainer, Piston	1
428	32926	NBR	O-Ring, Retainer	1
429	—	NBR	O-Ring, Piston Stem	1
430	—	PTFE	Back-up-Ring, Piston Stem	1
435	34581	SS	Valve/Ball Assembly (M8)	1
436	34575	SS	Seat	1
437	—	FPM	O-Ring, Seat	1
440	—	BB	Valve Body	1
441	—	NBR	O-Ring, Check Valve	1
442	33856	STL	Washer, Seal (3/8")	2
443	33339	S	Valve, Check	1
444	33843	S	Spring	1
454	—	NBR	O-Ring, Manifold	1
456	—	BB	Manifold	1
460	31855	BB	Fitting, Discharge (3/8" NPTF)	1
462	—	—	Screw, Flow-thru (3/8" NPTF)	1
463	—	—	Screw, Flow-thru (1/2" NPTF)	1
464	33854	STL	Washer, Seal (1/2")	2
468	34498	NBR	Kit, O-Ring Incls: 415, 416, 424, 428, 429, 430, 437, 441, 454)	1
469	7243	—	Injector (Included)	1
—	7644	BB	Unloader Assembly w/o Chemical Injector	1

\*NOTE: Piston stem has a special teflon guide ring with internal compression o-ring to provide low-friction stem movement at high pressure. A minute amount of fluid may weep from the piston retainer weep hole during the low pressure cycle. This is normal. Prolonged or excessive weeping indicates a need for valve servicing.

*Italics are optional items.*

MATERIAL CODES (Not Part of Part Number):

BB=Brass FPM=Fluorocarbon (Viton®) NBR=Medium Nitrile (Buna-N)

PTFE=Pure Teflon® S=304SS SS=316SS SSSS=440SS STZP=Steel/Zinc Plated

## 7243 FIXED CHEMICAL INJECTOR

Specifications	U.S. Measure	Metric Measure
Flow.....	3.0-5.0 GPM	(11.4-19 L/M)
Nozzle Orifice.....	2.1 mm	(2.1 mm)
Hose Barb - Ext.....	1/4"	(1/4")
Hose Barb - Int.....	8/32" UNCF	(8/32" UNCF)
Inlet Port.....	M22 x 1.5	(M22 x 1.5)
Discharge Port.....	3/8" NPTM	(3/8" NPTM)
Weight.....	6.3 oz.	(0.18 kg)
Dimensions.....	2.25 x 1.0 x 2.63"	(57 x 25 x 67 mm)

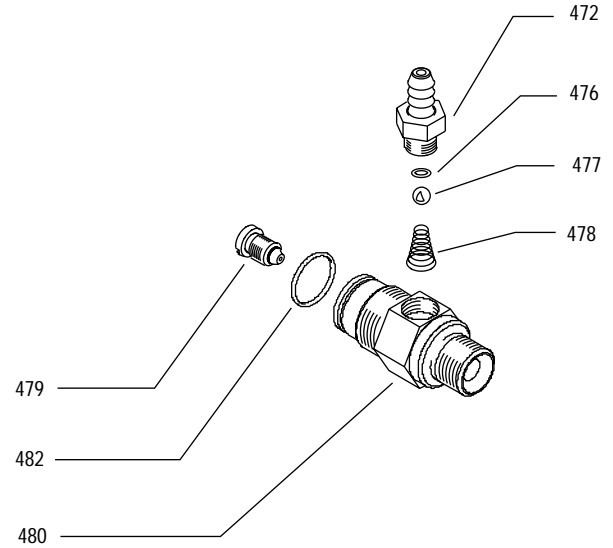

### PARTS LIST

ITEM	P/N	MATL	DESCRIPTION	QTY.
472	33505	BB	Barb, Fixed	1
476	33504	FPM	O-Ring, Retainer	1
477	34620	SS	Ball (1/4")	1
478	33501	SS	Spring	1
479	32373	S	Injector Orifice (2.1 mm)	1
480	—	BB	Body, Unloader Mount	1
—	33480	BB	Fixed Barb Assembly (Incls: 472,476,477,478)	1
482	34503	FPM	O-Ring	1

*Italics are optional items.*

MATERIAL CODES (Not Part of Part Number):

BB=Brass FPM=Fluorocarbon (Viton®) S=304SS SS=316SS

### CHEMICAL INJECTOR PERFORMANCE CHART

Desired Pump Flow	Orifice Size	Injector Model	Lo-Pressure Nozzle (Maximum injecting pressure less hose friction loss)	Max. Chem. Draw (0 PSI) (Downstream)	Hi-Press Nozzle "Deduction" (Press drop across Inj.)
3.5	2.1 mm	7243	350 PSI	50 oz/min	350 PSI
4.0	2.1 mm	7243	375 PSI	54 oz/min	250 PSI

## INSTALLATION:

A Modular Regulating Unloader with Chemical Injector comes with each 6DX pump to provide system pressure regulation, pump protection and metered chemical application. The Unloader is mounted directly onto the pump with flow-thru screws.

On systems over 2000 PSI SECONDARY PROTECTION is recommended by installing a pop-off valve, safety valve or rupture disc.

## OPERATION:

Set the unloader while the high pressure system is turned on. Adjust in small increments until the desired system pressure is reached. Install a pressure gauge to check pressure during start-up and periodically during operation.

If unit is infrequently used or periodically stored, seals may become dry. Check seals before commencing operation.

The system must be purged before operation (system liquid must flow through the pump without discharge restriction) to assure full system pressure is reached.

Optimum performance of chemical injector occurs with a 35 ft. high pressure hose and a minimum 3/8" I.D. The type of hose, extended lengths, reduced I.D. and fittings may create back pressures in excess of the low pressure nozzle rating and prevent the injector from drawing chemical. See Hose Friction Loss Chart in Service Manual. **Deduct hose friction loss from above low PSI Nozzle. Consult factory for assistance with other options.**

### CAUTION:

Deduct the pressure drop shown in the performance chart from your desired system pressure to arrive at the maximum high pressure nozzle rating. This is essential to avoid over-pressurizing the pump.

**NOTE:** For correct nozzle selection, read system pressure at the pump. DO NOT READ SYSTEM PRESSURE AT THE HIGH PRESSURE GUN. Incorrect pressure reading may result in: pump operation at excessive pressures, inconsistent chemical draw or possible damage to the pump or unloader.

## 6DX DIMENSIONAL

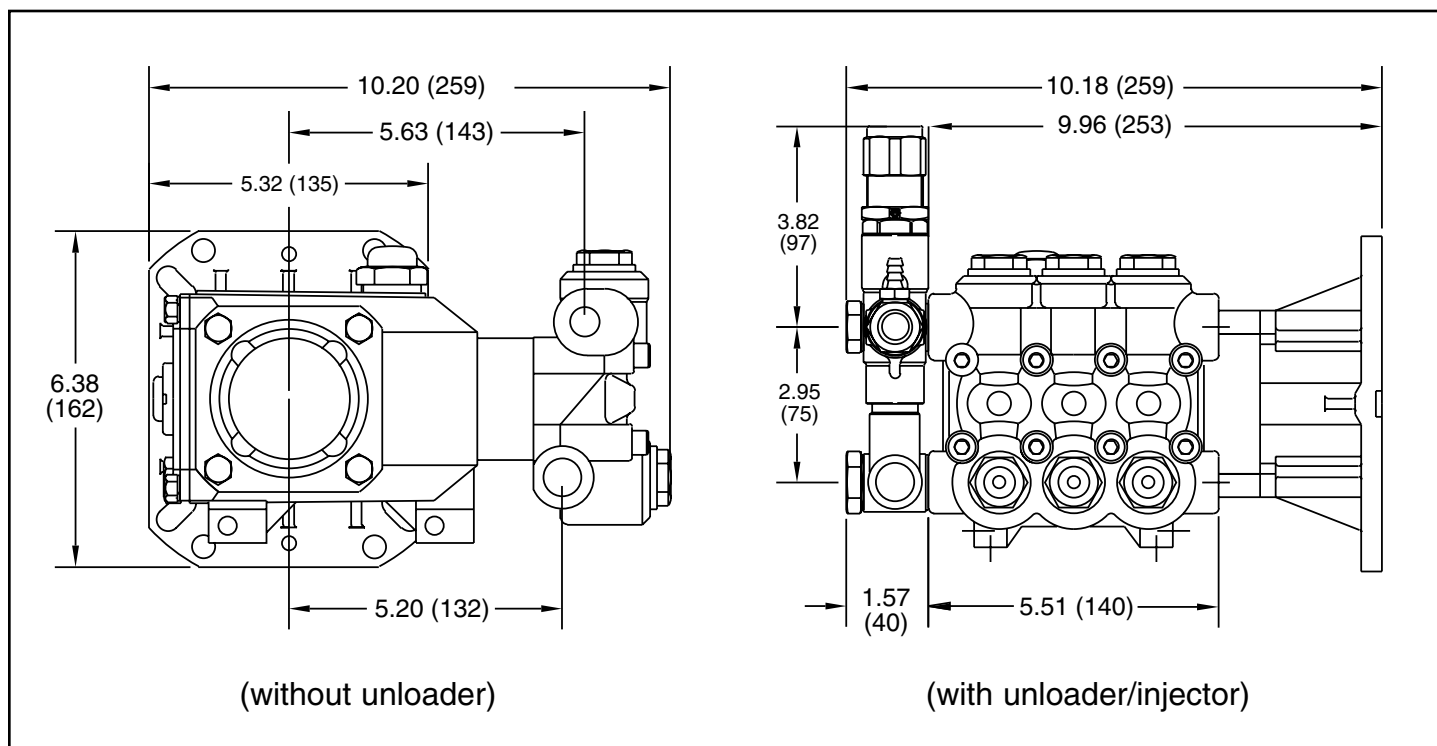

Jan 2001 1106

### World Headquarters

#### CAT PUMPS

1681 - 94th Lane N.E. Minneapolis, MN 55449-4324

Phone (763) 780-5440 — FAX (763) 780-2958

e-mail: sales@catpumps.com

www.catpumps.com

### International Inquiries

FAX (763) 785-4329

e-mail: intlsales@catpumps.com



*"The World's Most Dependable Pumps"*

### CAT PUMPS (U.K.) LTD.

1 Fleet Business Park, Sandy Lane, Church Crookham, Fleet

Hampshire GU13 0BF, England

Phone Fleet 44 1252-622031 — Fax 44 1252-626655

e-mail: sales@catpumps.co.uk

### N.V. CAT PUMPS INTERNATIONAL S.A.

Heiveldekens 6A, 2550 Kontich, Belgium

Phone 32-3-450.71.50 — Fax 32-3-450.71.51

e-mail: cpi@catpumps.be www.catpumps.be

### CAT PUMPS DEUTSCHLAND GmbH

Buchwiese 2, D-65510 Idstein, Germany

Phone 49 6126-9303 0 — Fax 49 6126-9303 33

e-mail: catpumps@t-online.de www.catpumps.de