

DATA SHEET

15 FRAME PLUNGER PUMPS



Brass Model: 1540E.44101

Stainless Steel Model: 1541.44101

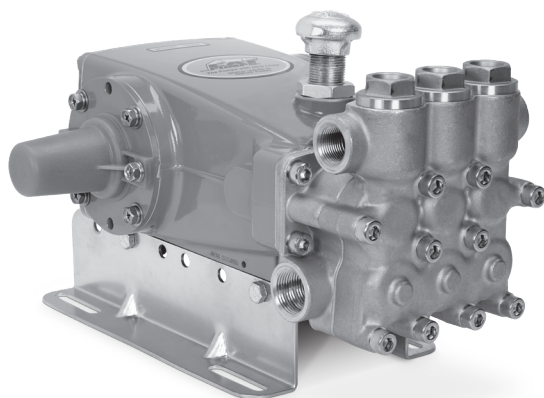

Model 1540E.44101 Shown
(Shaft protector included and mounting rails sold separately)

SPECIFICATIONS	U.S. Measure	Metric Measure
Flow	19.3 gpm	73.0 lpm
Pressure Range	100–1200 psi	6.9–83 bar
Pump RPM*	1180 rpm	1180 rpm
Inlet Pressure Range	Flooded to 70 psi	Flooded to 4.8 bar
Max. Liquid Temperature	240°F	115°C
Bore	1.181"	30 mm
Stroke	1.181"	30 mm
Crankcase Capacity	42 oz.	1.26 l
Inlet Ports (2)	1" NPT(F)	1" NPT(F)
Discharge Ports (2)	¾" NPT(F)	¾" NPT(F)
Shaft Diameter	1.181"	30 mm
Pulley Mounting	Either Side	Either Side
Weight	42.6 lbs.	21 kg
Dimensions	14.79 x 12.99 x 8.25"	376 x 330 x 210 mm

*Pump minimum is 100 RPM.

FEATURES

- Field-tested, high-pressure triplex pump configured for high-temperature TEG (triethylene glycol) applications up to 240°F/115°C. May be used in other high-temperature applications with fluids possessing adequate lubrication properties. Contact Cat Pumps for more information.
- Positive displacement technology delivers optimum energy efficiency.
- TEG* pump configuration option consists of following materials:
 - O-Ring material throughout the pump: FPM elastomers.
 - Oil filler cap assembly: brass adapters, chrome-plated steel vented cap.
 - Rear sight gauge assembly: aluminum sight adapter and stainless steel sight gauge.
 - Seal retainers: aluminum.
 - Low-pressure seals and V-packings: special PTFE blends.

* TEG pump configuration is denoted by adding ".44101" to the end of the pump model

ELECTRIC HORSEPOWER REQUIREMENTS

HORSE POWER	PRESSURE						FLOW		PUMP RPM
	PSI		BAR		PSI		BAR		
	800	55	1000	69	1200	83	GPM	LPM	
						19.3	73	1180	
	10.6		13.2		15.9				

$$\frac{\text{Rated gpm}}{\text{Rated rpm}} = \frac{\text{Desired gpm}}{\text{Desired rpm}}$$

$$\frac{\text{gpm} \times \text{psi}}{1460} = \frac{\text{Electric Brake H.P. Required}}{\text{H.P. Required}}$$

$$\frac{\text{Motor Pulley O.D.}}{\text{Pump rpm}} = \frac{\text{Pump Pulley O.D.}}{\text{Motor rpm}}$$

Refer to pump **Service Manual** for repair procedure and additional technical information.

PARTS LIST

ITEM	PN 1540E.44101	MATL	PN 1541.44101	MATL	DESCRIPTION	QTY
5	49651	S	49651	S	Screw, HHC Sems (M6 x 16) (See Tech Bulletin 074, 128)	8
8	134805	ALE	134805	ALE	Cover, Bearing (See Tech Bulletin 118, 128)	2
9	855043	FBR	855043	FBR	Shim, Split 2-Piece (See Tech Bulletin 128)	0-2
10	76340	FPM	76340	FPM	O-Ring, Bearing Cover - 75D	2
11	76491	FPM	76491	FPM	Seal, Oil, Crankshaft	2
12	855044	S	855044	S	Shim, Split, 2-Piece (See Tech Bulletin 128)	0-2
15	39060	STL	39060	STL	Bearing, Roller	2
20	48600	TNM	48600	TNM	Rod, Connecting Assembly (See Tech Bulletin 074)	3
25	43494	FCM	43494	FCM	Crankshaft, Dual-End (M30)	1
31	76411	BB	76411	BB	Adapter, 3/4" NPT(F)	1
32	992623	BB	992623	BB	Nipple, Close 3/4" NPT(F)	1
33	76331	STCP	76331	STCP	Cap, Vented	1
36	76792	SS	76792	SS	Gauge, Sight	1
37	76791	AL	76791	AL	Adapter, Sight	1
38	44428	NBR	44428	NBR	Gasket, Flat, Adapter - 80D	1
40	92542	S	92542	S	Screw, HHC Sems (M6 x 20) (See Tech Bulletin 074)	4
48	25625	STCP	25625	STCP	Plug, Drain (1/4" x 19 BSP)	1
49	30322	FPM	30322	FPM	O-Ring, Drain Plug	1
50	133576	ALE	133576	ALE	Cover, Rear (See Tech Bulletin 118)	1
51	76834	FPM	76834	FPM	O-Ring, Rear Cover - 75D	1
53	134858	ALE	134858	ALE	Crankcase (With Guide Pins) (See Tech Bulletin 118, 128)	1
54	27488	S	27488	S	Pin, Guide	2
64	43507	CM	43507	CM	Pin, Crosshead	3
65	48933	SHS	49611	SS	Rod, Plunger (Center)	1
66	48931	SHS	49609	SS	Rod, Plunger (Outside)	2
69	126596	STCP R	126596	STCP R	Washer, Oil Seal	3
70	76500	FPM	76500	FPM	Seal, Oil Crankcase	3
75	48937	S	48937	S	Slinger, Barrier	3
90	48938	CC	48938	CC	Plunger, Ceramic (M30 x 65)	3
98	48394	FPM	48394	FPM	Washer, Seal - 90D	3
99	† 48201	SS	† 48201	SS	Retainer, Plunger (See Tech Bulletin 074)	3
100	76926	AL	76926	AL	Retainer, Seal	3
106	702939	ST4	702939	ST4	Seal, LPS with NIH-Spring	3
110	48940	FBB	49614	SS	Manifold, Inlet	1
112	76903	FPM	76903	FPM	O-Ring, Inlet Manifold - 80D	3
117	49044	S	49044	S	Screw, HSH (M10 x 25) (See Tech Bulletin 074)	4
125	702945	ST4	702945	ST4	Seal, HPS	3
155	76903	FPM	76903	FPM	O-Ring, Spacer - 80D	6
157	48946	BB	49621	SS	Spacer, HPS	3
163	14331	FPM	14331	FPM	O-Ring, Seat - 70D	6
164	48951	S	49626	SS	Seat	6
166	48686	SS	48686	SS	Valve	6
167	48687	SS	48687	SS	Spring, Valve	6
168	48994	PVDF	48994	PVDF	Retainer, Spring	6
170	123764	S	49627	SS	Washer, Spring Retainer	6
172	14183	FPM	14183	FPM	O-Ring, Valve Plug	3
174	48952	FBB	49628	SSZZ	Plug, Valve (See Tech Bulletin 074)	3
185	48948	FBB	49623	SS	Manifold, Discharge	1
188	87952	S	87952	S	Screw, HSH (M10 x 55) (See Tech Bulletin 074)	10
250	855046	NY	855047	NY	Protector, Shaft with 2 Screws (See Tech Bulletin 128)	1

Optional Parts and Accessories on Page 4

† Production parts are different than replacement parts. R Components comply with RoHS Directive.

For additional technical information see www.catpumps.com/literature/tech-bulletins. MATERIAL CODES (Not Part of Part Number):

AL=Aluminum ALE=Aluminum Epoxy BB=Brass CC=Ceramic CM=Chrome-moly FBB=Forged Brass FBR=Fiber FCM=Forged Chrome-moly FPM=Fluorocarbon
NBR=Medium Nitrile (Buna-N) PVDF=Polyvinylidene Fluoride S=304SS SHS=304SS/High Strength SS=316SS SSZZ=316SS/Zamak ST4=Special PTFE 4
STCP=Steel/Chrome Plated STL=Steel TNM=Special High Strength

EXPLODED VIEW

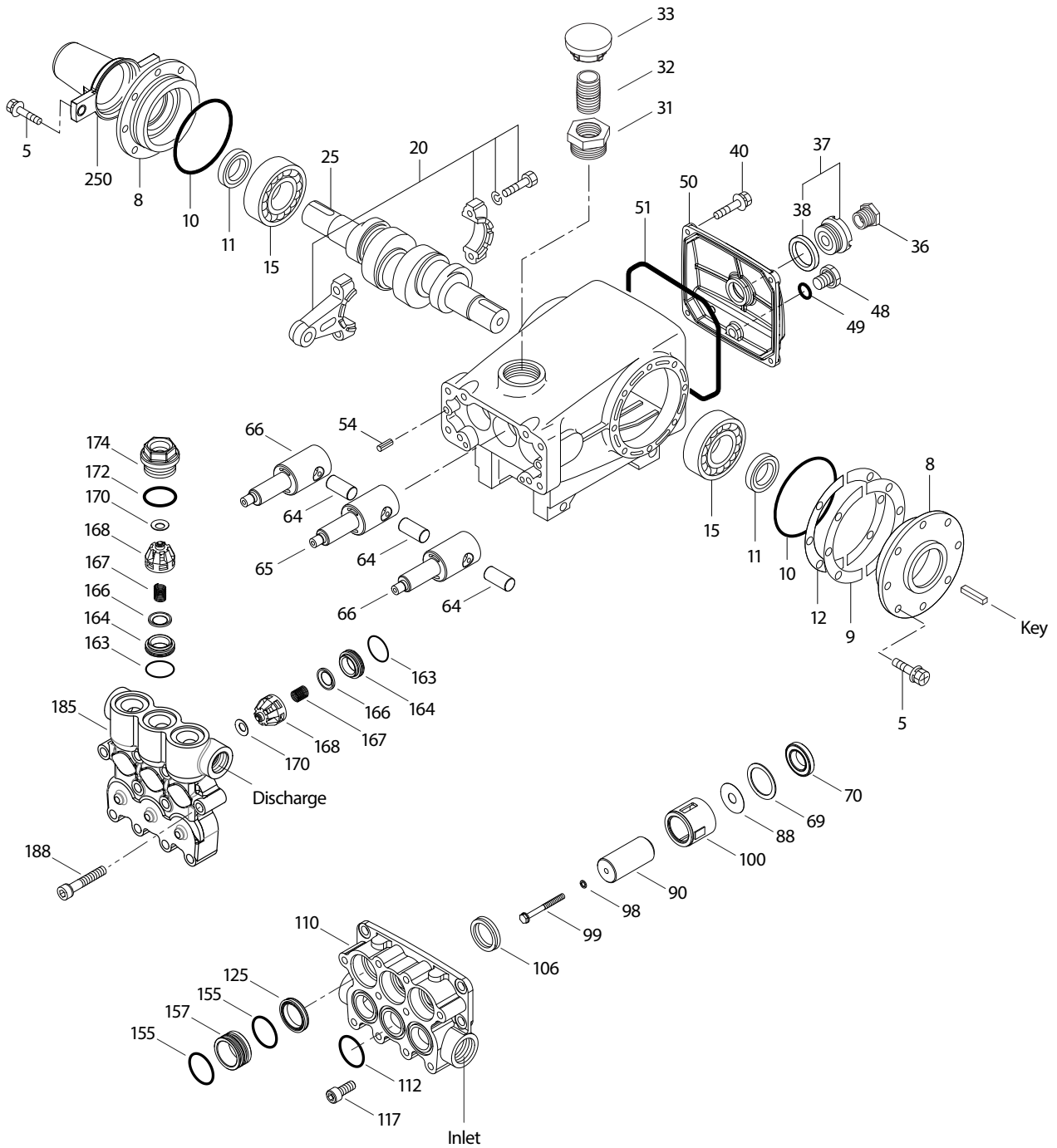

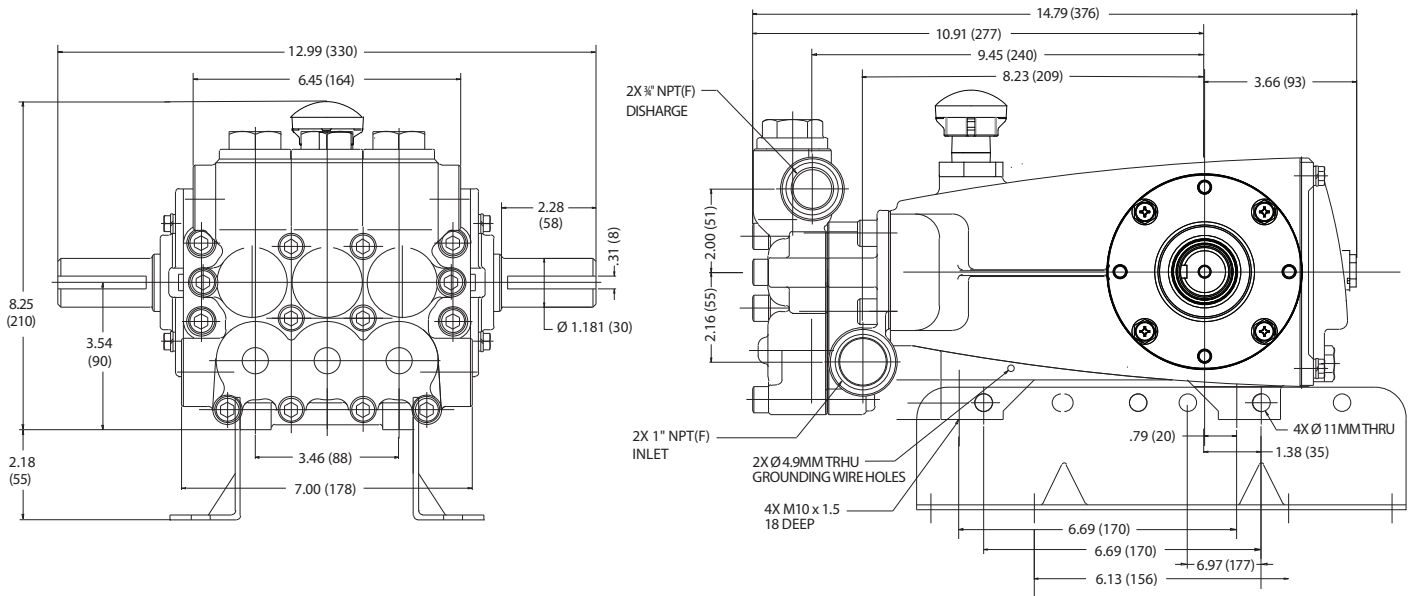

Models 1540E.44101, 1541.44101

REPAIR KITS AND PARTS

PART NUMBER	DESCRIPTION	QTY
76093 (1540E.44101)	Kit, Seal (Includes Items 98, 106, 112, 125, and 155)	1
76775 (1541.44101)	Kit, Valve (Includes Items 163, 164, 166, 167, 168, 170 and 172)	2
6107	Oil, Bottle (21 oz.) ISO 68 Hydraulic	2
30067 / 990036	Key (M8 x 7.5 x 25) / (M8 x 7 x 40)	1
6119	Lubricant, Antiseize (2 oz.)	1



7022
7022.100

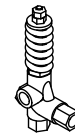

7537.1110
7531.1110

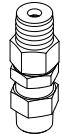

9940.0110
9941.0110

OPTIONAL PARTS AND ACCESSORIES

PART NUMBER	DESCRIPTION	QTY
7022 / 7022.100	Regulator (Primary Pressure Control)	1
7537.1110 / 7531.1110	Relief Valve (Primary or Secondary Pressure Control)	1
9940.0110 / 9941.0110	Pop-Off Valve (Secondary Pressure Control)	1
6073	Pressure Gauge	1
6013	Pulsation Dampener	1
30613	Mount, Rail Assembly	1
76334	Kit, Oil Indicator (3/8" x 24") See Individual Data Sheet	1
34334	Kit, Oil Drain (3/8" x 24") See Individual Data Sheet	1
30696	Pliers (Reverse)	1
44050	Tool, Sight Gauge Removal	1



6073



6013

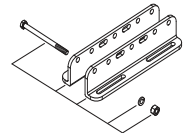

30613

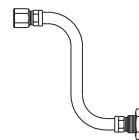

34334



6107

⚠ CAUTIONS AND WARNINGS

All high-pressure systems require a primary pressure regulating device (i.e. regulator, unloader) and a secondary pressure relief device (i.e. pop-off valve, relief valve). Failure to install such relief devices could result in personal injury or damage to pump or property. Cat Pumps does not assume any liability or responsibility for the operation of a customer's high-pressure system.

Read all CAUTIONS and WARNINGS before commencing service or operation of any high-pressure system. The CAUTIONS and WARNINGS are included in each Service Manual and with each Accessory Data sheet. CAUTIONS and WARNINGS can also be viewed online at www.catpumps.com/dynamic-literature/cautions-and-warnings or can be requested directly from Cat Pumps.

WARRANTY

View the Limited Warranty on-line at www.catpumps.com/literature/cat-pumps-limited-warranty