

DATA SHEET

25 FRAME PLUNGER PUMP

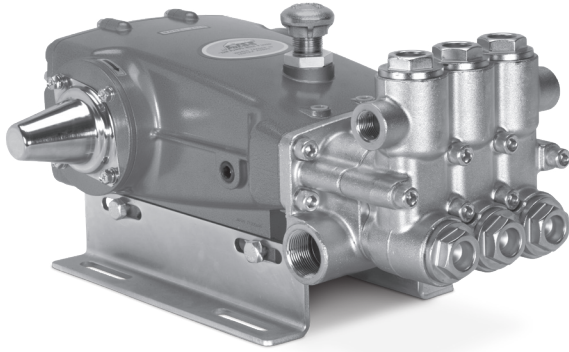

Brass Model: 2510.44101



Model 2510.44101 Shown
(Rails and shaft protector sold separately)

FEATURES

- Field-tested, high-pressure triplex pump configured for high-temperature TEG (triethylene glycol) applications up to 240°F/115°C. May be used in other high-temperature applications with fluids possessing adequate lubrication properties. Contact Cat Pumps for more information.
- Positive displacement technology delivers optimum energy efficiency.
- TEG* pump configuration option consists of following materials:
 - O-Ring material throughout the pump: FPM elastomers.
 - Oil filler cap assembly: brass adapters, chrome-plated steel vented cap.
 - Rear sight gauge assembly: aluminum sight adapter and stainless steel sight gauge.
 - Seal retainers: aluminum.
 - Low-pressure seals and V-packings: special PTFE blends.

* TEG pump configuration is denoted by adding ".44101" to the end of the pump model

SPECIFICATIONS	U.S. Measure	Metric Measure
Flow	20 gpm	76 lpm
Pressure Range	100–2000 psi	6.9–138 bar
Pump RPM*	1450 rpm	1450 rpm
Inlet Pressure Range	Flooded to 70 psi	Flooded to 4.8 bar
Maximum Liquid Temperature	240°F	115°C
Bore	0.984"	25 mm
Stroke	1.516"	38.5 mm
Crankcase Capacity	84 oz	2.48 l
Inlet Ports (2)	1 ¼" NPT(F)	1 ¼" NPT(F)
Discharge Ports (2)	¾" NPT(F)	¾" NPT(F)
Pulley Mounting	Either side	Either side
Shaft Diameter	1.181"	30 mm
Weight	79 lbs	36 kg
Dimensions	20.45 x 15.04 x 8.46"	519 x 382 x 215 mm

*Pump minimum is 100 RPM.

ELECTRIC HORSEPOWER REQUIREMENTS

HORSE POWER	PRESSURE						FLOW		PUMP RPM
	PSI		BAR		PSI		BAR		
	1000	69	1500	103	2000	138	GPM	LPM	
							20	76	1450
	13.7		20.5		27.4				

DETERMINING THE PUMP R.P.M.	Rated gpm	=	Desired gpm
	Rated rpm	=	Desired rpm
DETERMINING THE REQUIRED H.P.	gpm x psi	=	Electric Brake H. P. Required
	1460	=	
DETERMINING MOTOR PULLEY SIZE	Motor Pulley O.D.	=	Pump Pulley O.D.
	Pump rpm	=	Motor rpm

Refer to pump **Service Manual** for repair procedure and additional technical information.

PARTS LIST

ITEM	PART NUMBER	MATL	DESCRIPTION	QTY
5	126544	STCP R	Screw, HHC Sems (M8 x 25) (See Tech Bulletin 074)	8
8	49533	ALE	Cover, Bearing	2
10	76772	FPM	O-Ring, Bearing Cover – 75D	2
11	76771	FPM	Seal, Oil, Crankshaft	2
15	26512	STL R	Bearing, Ball	2
20	48613	TNM	Rod, Connecting Assembly (Includes: Lockwasher, Washer, Screw) (See Tech Bulletin 074)	3
21	126562	STCP R	Washer, Locking	3
25	49795	FCM	Crankshaft, Dual-End (M38.5)	1
31	76411	BB	Adapter, 3/4" NPT(F)	1
32	992623	BB	Nipple, Close 3/4" NPT(M)	1
33	76331	STCP	Cap, Vented, 3/4" NPT(F)	1
35	26996	FPM	O-Ring, Dip Stick – 70D	1
36	76792	SS	Gauge, Sight	1
37	76791	AL	Adapter, Sight	1
38	44428	NBR	Gasket, Flat, Oil Gauge – 80D	1
39	76769	AL	Dip Stick	1
40	126544	STCP R	Screw, HHC Sems (M8 x 25) (See Tech Bulletin 074)	8
48	25625	STCP	Plug, Drain (1/4" x 19 BSP)	1
49	30322	FPM	O-Ring, Drain Plug	1
50	133582	ALE	Cover, Rear (See Tech Bulletin 126)	1
51	76767	FPM	O-Ring, Rear Cover – 70D	1
53	133609	ALE	Crankcase with Guide Pins	1
54	27488	S	Pin, Guide	2
64	27784	CM	Pin, Crosshead	3
65	48719	SSHS	Rod, Plunger	3
70	76785	FPM	Seal, Crankcase Oil	3
75	110669	S	Slinger, Barrier	3
88	110670	S	Washer, Keyhole	3
90	48535	CC	Plunger, Ceramic (M25 x 110)	3
95	126549	STCP R	Stud, Plunger Retainer (M7 x 103)	3
96	20184	PTFE	Backup Ring, Plunger Retainer	3
97	14161	FPM	O-Ring, Plunger Retainer – 70D	3
98	44069	SS	Gasket, Plunger Retainer	3
99	44068	SS	Retainer, Plunger (M7) (See Tech Bulletin 074)	3
100	76116	AL	Retainer, LPS	3
106	76086	ST2	Seal, LPS with S-Spring	3
107	48537	BB	Washer, LPS	3
110	48536	BBCP	Manifold, Inlet	1
112	14183	FPM	O-Ring, Inlet Manifold	3
117	126510	STCP R	Screw, HSH (M12 x 35) (See Tech Bulletin 074)	4
126	48538	BB	Adapter, Female	3
127	76611	ST4	V-Packing	6
128	48539	BB	Adapter, Male	3
141	48672	SS	Spring, Coil	18
142	48550	BB	Spacer with Coil Springs	3
155	14183	FPM	O-Ring, Spacer–Rear	3
156	28243	PTFE	Backup Ring, Spacer–Rear	3
158	28243	PTFE	Backup Ring, Spacer–Front	3
159	14183	FPM	O-Ring, Spacer–Front	3
162	44614	PTFE	Backup Ring, Seat	6
163	14330	FPM	O-Ring, Seat – 70D	6
164	48544	S	Seat	6
166	45839	SS	Valve	6
167	45840	SS	Spring	6
168	110682	PVDF	Retainer, Spring	6
170	44794	SS	Washer, Spring Retainer	6
171	48689	SS	Spring, Coil	6
172	11745	FPM	O-Ring, Valve Plug – 70D	6
174	120693	BBCP	Plug, Valve (See Tech Bulletin 074)	6
185	48543	BBCP	Manifold, Discharge	1
188	126511	STCP R	Screw, HSH (M12 x 80) (See Tech Bulletin 074)	6

Repair kits, Optional Parts and Accessories on Page 4.

Italics are optional items. [] Date of latest production change.

R Components comply with RoHS Directive. * Review material codes for individual items (STG generally may be used as alternate).

For additional technical information see www.catpumps.com/literature/tech-bulletins

MATERIAL CODES (Not Part of Part Number): AL=Aluminum ALE=Aluminum Epoxy BB=Brass BBCP=Brass/Chrome Plated CC=Ceramic
 CM=Chrome-Moly FCM=Forged Chrome-Moly FPM=Fluorocarbon NBR=Medium Nitrile (Buna-N) PC=Poly Carbonate PTFE=Pure Polytetrafluoroethylene
 PVDF=Polyvinylidene Fluoride S=304SS SS=316SS SSHS=316SS/High Strength STCP=Steel/Chrome Plated STG=Special Blend PTFE White
 STL=Steel ST2=Special PTFE 2 ST4=Special PTFE 4 TNM=Special High Strength

EXPLODED VIEW

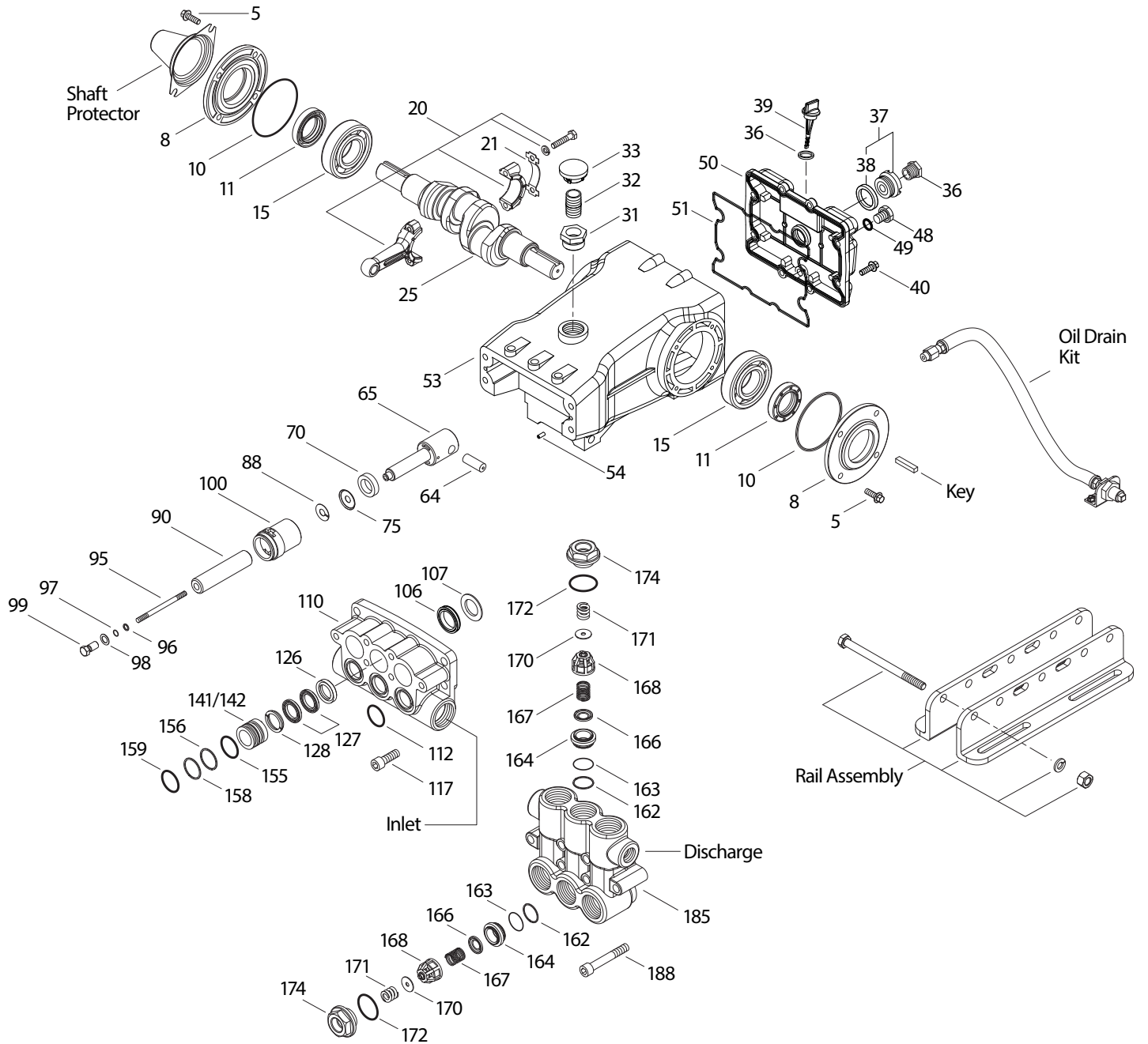

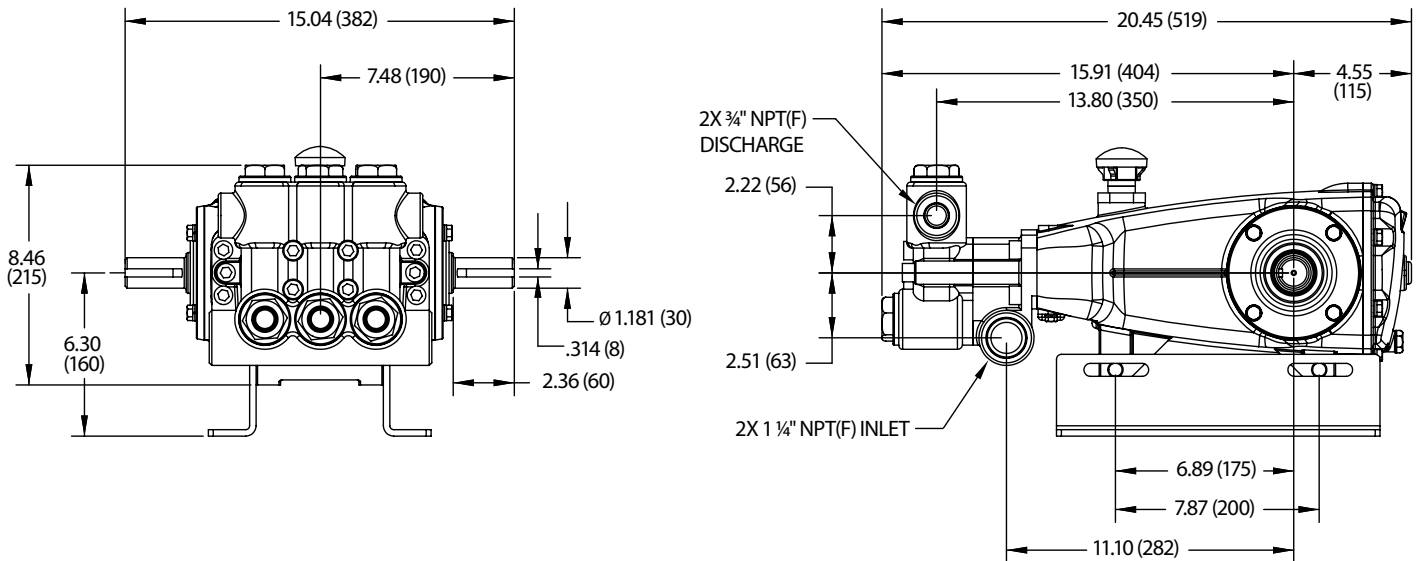

Model 2510.44101

REPAIR KITS AND PARTS

Part Number	Description	QTY
31392	Kit, Seal (Includes Items 97, 106, 112, 127, 155, 156, 158 and 159)	1
31385	Kit, Valve (Includes Items 162, 163, 164, 166, 167, 168, 170 and 172)	2
6107	Oil, Bottle (21 oz) ISO 68 Hydraulic	4
6119	Lubricant, Antiseize (2 oz)	1
990036	Key (M8 x 7 x 40)	1



7022

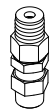

9940.0110

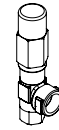

7595.0110

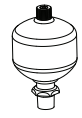

6013

OPTIONAL PARTS AND ACCESSORIES

Part Number	Description	QTY
7022	Regulator (Primary Pressure Control)	1
7595.0110	Relief Valve (Primary or Secondary Pressure Control)	1
9940.0110	Pop-Off Valve (Secondary Pressure Control)	1
6073	Pressure Gauge	1
6013	Pulsation Dampener	1
30614	Mount, Rail Assembly	1
26516	Shaft Protector	1
76144	Kit, Oil Indicator (3/8" x 24") See Individual Data Sheet	1
34334	Kit, Oil Drain (3/8" x 24") See Individual Data Sheet	1
30696	Reverse Pliers	1



26516



6073



6107



34334

CAUTIONS AND WARNINGS

All high-pressure systems require a primary pressure regulating device (i.e. regulator, unloader) and a secondary pressure relief device (i.e. pop-off valve, relief valve). Failure to install such relief devices could result in personal injury or damage to pump or property. Cat Pumps does not assume any liability or responsibility for the operation of a customer's high-pressure system.

Read all CAUTIONS and WARNINGS before commencing service or operation of any high-pressure system. The CAUTIONS and WARNINGS are included in each Service Manual and with each Accessory Data sheet. CAUTIONS and WARNINGS can also be viewed online at www.catpumps.com/dynamic-literature/cautions-and-warnings or can be requested directly from Cat Pumps.

WARRANTY

View the Limited Warranty on-line at www.catpumps.com/literature/cat-pumps-limited-warranty