

DATA SHEET

35 FRAME PLUNGER PUMPS



Brass Models: 3570, 3570S

Flushed Model: 3570C

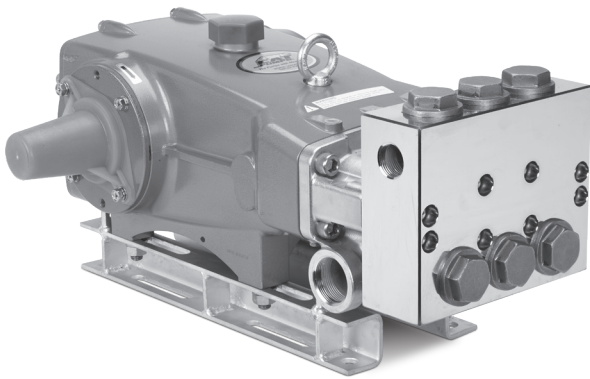

Model 3570 Shown
(Shaft protector included, mounting rails sold separately)

FEATURES

- Triplex design delivers high-efficiency and low-pulsation.
- Durable dual V-packings are lubricated and cooled by pumped liquid.
- Pre-set low-pressure seals provide secondary protection against external leaks and require no packing adjustment.
- Special high-density, polished, concentric plungers provide a true wear surface and extended seal life.
- Special flushed inlet manifold on 3570C permits external flush for added cooling with high-temperature liquids and lubrication with low-lubricity liquids.
- Standard pumps are fitted with NBR seals. Optional seals are available for higher temperatures or chemical compatibility.

SPECIFICATIONS	U.S. Measure	Metric Measure
Flow*	30 gpm	114 lpm
Pressure Range* (3570S)	100–3000 psi	6.9–207 bar
Pressure Range (3570, 3570C)	100–2500 psi	6.9–170 bar
Pump RPM**	1080 rpm	1080 rpm
Inlet Pressure Range	Flooded to 70 psi	Flooded to 4.8 bar
Max. Liquid Temp. (NBR)	120° F	48° C
Alternative seals available for higher temperatures up to 140° F		
Bore	1.260"	32 mm
Stroke	1.890"	48 mm
Crankcase Capacity	4.2 qts	4 L
Inlets Ports (2)	1 ½" NPT(F)	1 ½" NPT(F)
Flush Ports (2)	¼" NPT(F)	¼" NPT(F)
Discharge Ports (2)	1" NPT(F)	1" NPT(F)
Pulley Mounting	Either Side	Either Side
Shaft Diameter	1.378"	35 mm
Weight	138.9 lbs	63 kg
Dimensions	23.94 x 18.11 x 9.74"	608 x 460 x 247 mm

*Intermittent duty only

**Pump minimum is 100 RPM.

INTERMITTENT DUTY CYCLE DEFINED AS:

Operating pump at stated flow and pressure for no more than 50% of time in any given hour.

ALTERNATIVE SEAL CONFIGURATION

MATERIAL	SUFFIX CODE	MAXIMUM TEMPERATURE	
NBR	—	120° F	(48° C)
FPM	.0110	140° F	(60° C)

See **Tech Bulletin 002** for inlet conditions and RPM at high-temperature.

DETERMINING THE PUMP R.P.M.	Rated gpm	=	Desired gpm
	Rated rpm	=	Desired rpm
DETERMINING THE REQUIRED H.P.	Hp (Electric Brake)	=	$\frac{\text{gpm} \times \text{psi}}{1460}$
DETERMINING MOTOR PULLEY SIZE	Motor Pulley O.D.	=	Pump Pulley O.D.
	Pump rpm	=	Motor rpm

Refer to pump **Service Manual** for repair procedure and additional technical information.

PARTS LIST

ITEM	P/N	MATL	DESCRIPTION	QTY
2	34021	STL	Key (M10 x 8 x 70)	1
5	96049	S	Screw, HHC, Sems (M10 x 25) (See Tech Bulletin 125) [6/18]	8
8	134604	ALE	Cover, Bearing (See Tech Bulletin 118, 125) [6/18]	2
9	815279	FBR	Shim, Split, 2-Piece (See Tech Bulletin 125) [6/18]	3
10	12398	NBR	O-Ring, Bearing Cover – 70D	2
11	13296	NBR	Seal, Oil, Crankshaft	0–2
12	855049	S	Shim, Split, 2-Piece	3
15	29326	STL	Bearing, Roller	2
20	121467	TNM	Rod, Connecting Assembly (Includes: 21, 22, 23)	3
21	126749	STCP R	Washer, Locking (M10)	3
22	126593	STCP R	Washer, Flat (M10.5)	6
23	122045	STZP	Screw, HH (M10 x 55)	6
25	29325	FCM	Crankshaft, Dual End (M 48)	1
31	828710	PE	Protector, Oil Cap with Foam Gasket	1
32	43211	ABS	Cap, Oil Filler	1
33	14177	NBR	O-Ring, Oil Filler Cap – 70D	1
34	126743	STCP R	Bolt, Eye (M12 x 1.75) (For Lifting Pump Only)	1
37	92241	—	Gauge, Oil, Bubble with Gasket	1
38	44428	NBR	Gasket, Flat, Oil Gauge – 80D	1
40	125753	S	Screw, HHC, Sems (M8 x 25)	8
48	25625	STCP	Plug, Drain (¼" x 19 BSP)	1
49	23170	NBR	O-Ring, Drain Plug – 70D	1
50	45936	ALE	Cover, Crankcase (See Tech Bulletin 118)	1
51	16612	NBR	O-Ring, Crankcase – 70D	1
53	134784	ALE	Crankcase Assembly (Includes: 34, 54) (See Tech Bulletin 118, 125) [6/18]	1
54	27488	S	Pins, Guide	2
56	27790	POP	Pan, Oil	1
59	92538	S	Screw, HHC, Sems (M6 x 16)	2
64	43864	CM	Pin, Crosshead	3
65	49166	SSHB	Rod, Plunger	3
69	126587	STCP R	Washer, Oil Seal	3
70	100488	NBRS	Seal, Oil, Crankcase	3
	44739	FPM	Seal, Oil, Crankcase	3
75	43865	S	Slinger, Barrier	3
88	45676	S	Washer, Keyhole (M16)	3
90	43957	CC	Plunger (M32 X 145)	3
95	† 89778	SS	Stud, Plunger Retainer (M10 X 135)	3
96	20189	PTFE	Backup-Ring, Plunger Retainer	3
97	11345	NBR	O-Ring, Plunger Retainer – 70D	3
	11375	FPM	O-Ring, Plunger Retainer	3
98	44085	SS	Gasket, Retainer	3
99	† 44084	SS	Retainer, Plunger (M10)	3
100	44119	PPG	Retainer, Seal (See Tech Bulletin 105)	3
101	44106	—	Wick, Long Tab	3
104	43875	NBR	O-Ring, Adapter – 70D	3
	44826	FPM	O-Ring, Adapter – 70D	3
105	49741	BB	Adapter	3
106	† 44098	NBR	Seal, LPS with SS–Spring	3
	44827	FPM	Seal, LPS with SS–Spring	3
107	43962	S	Washer, LPS	3
110	49464	BBCP R	Manifold, Inlet – (Models 3570, 3570S)	1
	49464C	BBCP R	Manifold, Inlet, Flushed (¼" Flush Ports) – (Model 3570C)	1
112	11379	NBR	O-Ring, Inlet Manifold – 70D	3
	14183	FPM	O-Ring, Inlet Manifold	3
117	44585	S	Screw, HSH (M14 x 40)	4
122	49744	BB	Spacer, V-Packing	3
123	12391	NBR	O-Ring, Spacer – 70D	3
	13266	FPM	O-Ring, Spacer – 70D	3
124	49742	BB	Cylinder, V-Packing	3
126	43963	BB	Adapter, Female	3
127	† 44608	STG	V-Packing	6
128	43965	BB	Adapter, Male	3
141	49743	SS	Spring, Coil	3
155	48860	NBR	O-Ring, V-Packing Cylinder – 90D	3
	20137	FPM	O-Ring, V-Packing Cylinder – 70D	3
156	48362	D	Backup-Ring, V-Packing Cylinder	3
162	48363	D	Backup-Ring, Valve Seat	6
163	26142	NBR	O-Ring, Valve Seat – 80D	6
	14330	FPM	O-Ring, Valve Seat – 70D	6
164	133052	S	Seat, Valve	6
166	43932	S	Valve	6
167	133053	S	Spring	6
168	44728	PVDF	Retainer, Spring	6
170	44729	SS	Washer, Spring	6
171	44644	SS	Spring, Coil	6

EXPLODED VIEW

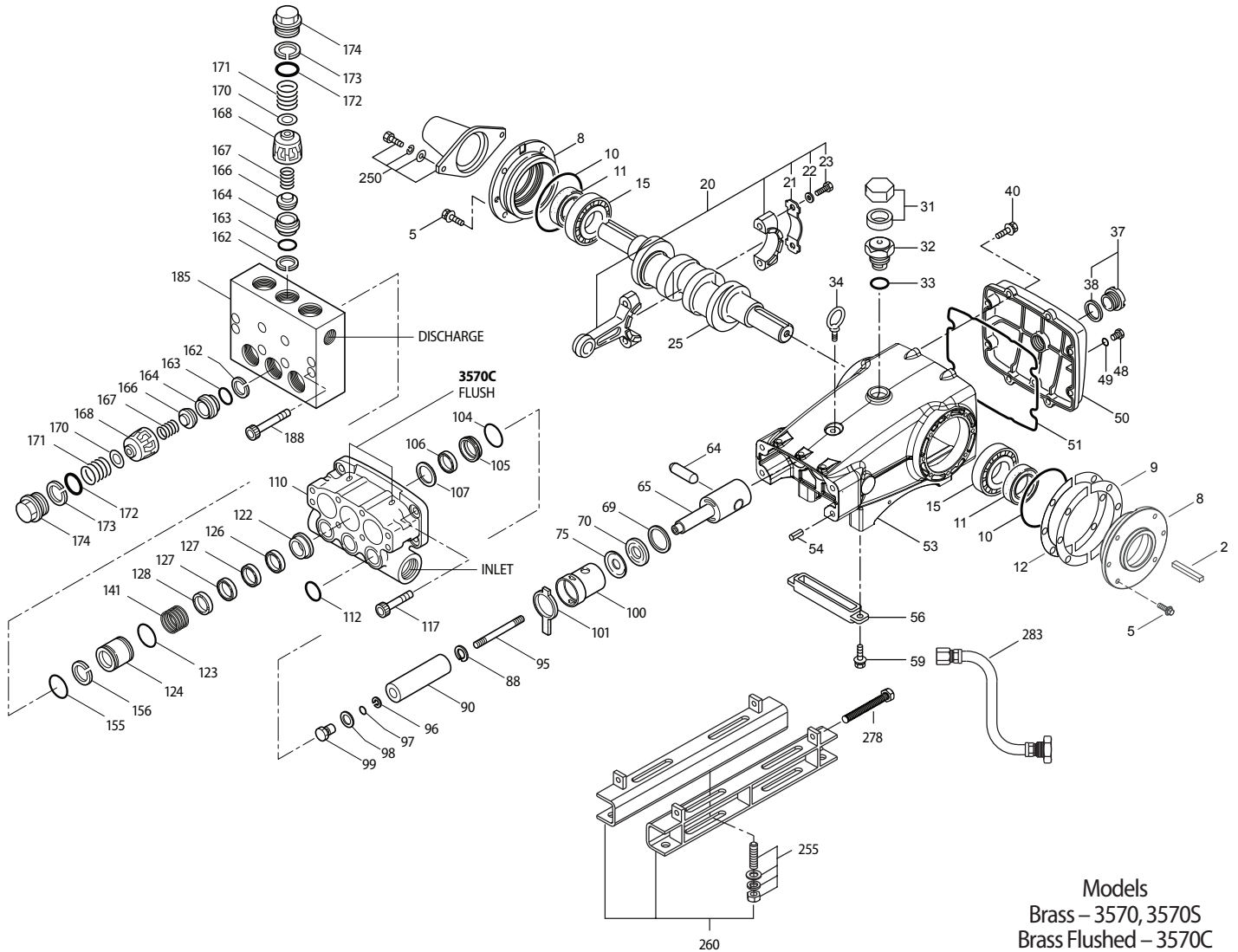

Models
 Brass – 3570, 3570S
 Brass Flushed – 3570C
 December 2020

ITEM	P/N	MATL	DESCRIPTION	QTY
	172	NBR	O-Ring, Valve Plug – 90D	6
	173	FPM	O-Ring, Valve Plug – 90D	6
	174	D	Backup-Ring, Valve Plug	6
	174	NAB	Plug, Valve	6
	185	133049	Manifold, Discharge (Models 3570, 3570C)	1
		<i>133559</i>	<i>Manifold, Discharge (Model 3570S)</i>	<i>1</i>
	188	S	Screw, HSH (M12 x 70)	8
	250	NY	Protector, Shaft with 2 Screws, Lockwashers and Washers (Included with Pump) (See Tech Bulletin 125) [6/18]	1
	255	STZP R	Kit, Direct Mount	1
	260	STZP R	Mount, Rail Assembly (Includes: 34018)	1
	278	STZP	Screw, HH (M12 x 100) (Rail Adjusting Screw)	2
	279	STZP	Oilers (1 oz) (Not Shown)	3
	283	—	Kit, Oil Drain (3/8" x 24") (See Individual Data Sheet)	1
	290	—	Gasket, Liquid (3 oz)	1
	299	BBCP	Head, Complete with NBR Seals and O-Rings (Model 3570 Only)	1
	300	NBR*	Kit, Seal (Includes: 97, 104, 106, 112, 123, 127, 155, 156) Standard	1
		FPM*	Kit, Seal (Includes: 97, 104, 106, 112, 123, 127, 155, 156) .0110	1
	310	NBR	Kit, Valve Preassembled (Includes: 162, 163, 164, 166, 167, 168, 170, 172, 173) Standard	2
		FPM	Kit, Valve Preassembled (Includes: 162, 163, 164, 166, 167, 168, 170, 172, 173) .0110	2
	—	—	Oil, Case (12 Bottles) ISO 68 Hydraulic (Fill to Specified Crankcase Capacity Prior to Start-Up)	1

Bold print part numbers are unique to a particular pump model. Italics are optional items.

* Review material codes for individual items (STG generally may be used as alternate). R Components comply with RoHS Directive.

[] Date of latest production change. For additional technical information see www.catpumps.com/literature/tech-bulletins. † Production parts different from service parts.

MATERIAL CODES (Not Part of Part Number): ABS=ABS Plastic ALE=Aluminum Epoxy BB=Brass BBCP=Brass/Chrome Plated CC=Ceramic CM=Chrome-Moly

D=Acetal FBR=Fiber FCM=Forged Chrome-Moly FPM=Fluorocarbon NAB=Nickel Aluminum Bronze NBR=Medium Nitrile (Buna-N) NBR5=Buna, Silicone Free

NY=Nylon PE=Polyethylene POP=Polypropylene PPG=Glass Filled Polypropylene PTFE=Pure Polytetrafluoroethylene PVDF=Polyvinylidene Fluoride S=304SS SS=316SS

SSH=316SS/High Strength STCP=Steel/Chrome Plated STG=Special Blend PTFE White STL=Steel STZP=Steel/Zinc Plated TNM=Special High Strength

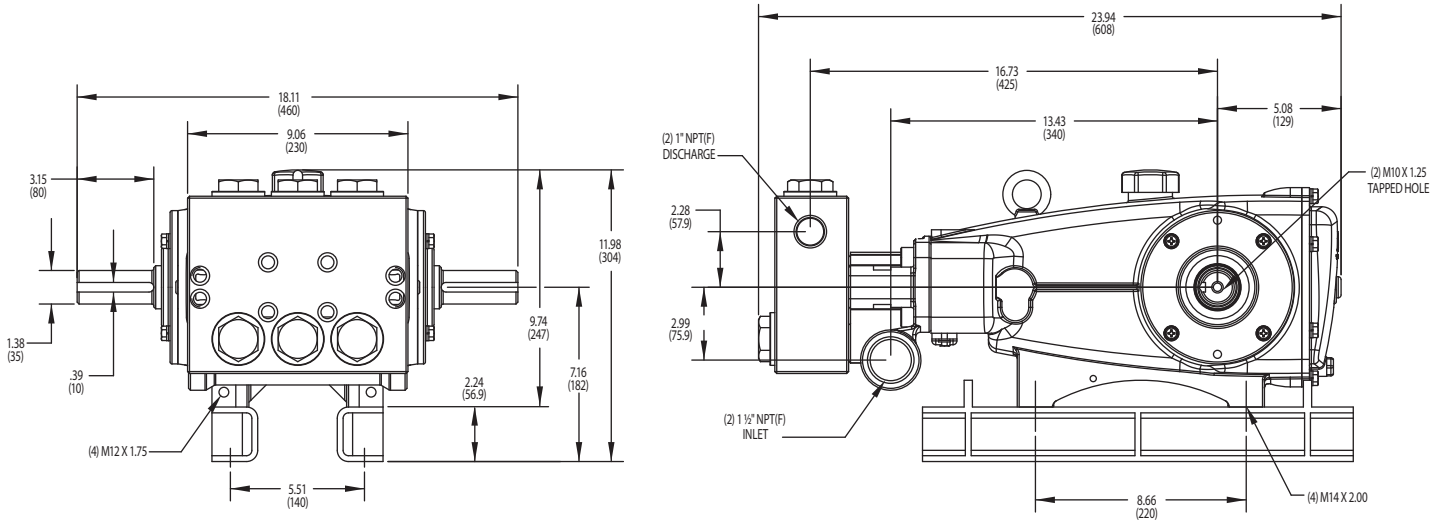

⚠ CAUTIONS AND WARNINGS

All high-pressure systems require a primary pressure regulating device (i.e. regulator, unloader) and a secondary pressure relief device (i.e. pop-off valve, relief valve). Failure to install such relief devices could result in personal injury or damage to pump or property. Cat Pumps does not assume any liability or responsibility for the operation of a customer's high-pressure system. Read all CAUTIONS and WARNINGS before commencing service or operation of any high-pressure system. The CAUTIONS and WARNINGS are included in each Service Manual and with each Accessory Data sheet. CAUTIONS and WARNINGS can also be viewed online at www.catpumps.com/dynamic-literature/cautions-and-warnings or can be requested directly from Cat Pumps.

WARRANTY

View the Limited Warranty on-line at www.catpumps.com/literature/cat-pumps-limited-warranty