

DATA SHEET

DIRECT DRIVE PLUNGER PUMPS



**Stainless Steel
Model:**

2SFQ42SEEL

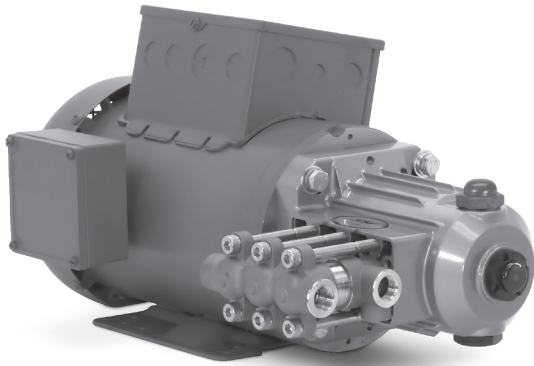

Motorized pump unit 2SFQ42SEELD251 Shown

FEATURES

- Unique spring loaded inlet valves and the flow through ceramic plungers provides a smooth, steady flow.
- Hollow shaft direct drive to provide the smallest possible footprint for challenging spaces.
- "Q" feature is designed for applications where a reduced sound level is desirable.

SPECIFICATIONS

	U.S. Measure	Metric Measure
Flow	4.2 gpm	15.9 lpm
Pressure Range	100 – 1200 psi	6.9 – 83 bar
Pump RPM	1725 rpm	1725 rpm
Inlet Pressure Range	Flooded to 60 psi	Flooded to 4.1 bar
Max. Liquid Temp. (NBR)	160° F	71° C
Alternative seals available for higher temperatures up to 180° F		
Bore	0.789"	20 mm
Stroke	0.402"	10.2 mm
Crankcase Capacity	10.1 oz	0.30 l
Inlet Port (1)	3/8" NPT(F)	3/8" NPT(F)
Discharge Ports (2)	3/8" NPT(F)	3/8" NPT(F)
By-Pass Return Port (1)	1/4" NPT(F)	1/4" NPT(F)
Shaft Diameter	5/8"	15.9 mm
Weight (Pump Only)	8.9 lbs	4 kg
Dimensions (Pump Only)	6.8 x 8.7 x 5.2"	173 x 221 x 133 mm

ALTERNATIVE SEAL CONFIGURATION

MATERIAL	SUFFIX CODE	MAXIMUM TEMPERATURE	
NBR	—	160° F	(71° C)
FPM	.0110	180° F	(82° C)
EPDM	.0220	160° F	(71° C)
IPFE	.0770	180° F	(82° C)
HT	.3000	180° F	(82° C)
STHT	.3400	180° F	(82° C)

See **Tech Bulletin 002** for inlet conditions and RPM at higher temperatures.

$$\text{DETERMINING THE PUMP R.P.M.} \quad \frac{\text{Rated gpm}}{\text{Rated rpm}} = \frac{\text{"Desired" gpm}}{\text{"Desired" rpm}}$$

$$\text{DETERMINING THE REQUIRED H.P.} \quad \text{Hp (Electric Brake)} = \frac{\text{gpm} \times \text{psi}}{1460}$$

Refer to pump **Service Manual** for repair procedure and additional technical information.

PARTS LIST

ITEM	PART NUMBER	MATL	DESCRIPTION	QTY
5	547445	S	Screw, HHC Sems (M6 X 14)	3
8	547153	AL	Cover, Bearing	1
10	14041	NBR	O-Ring, Bearing Cover-70D	1
11	55337	NBR	Seal, Oil Crankshaft	1
15	14488	STL	Bearing Inner, Ball	1
20	547046	TNM	Rod, Connecting	3
25	544694	CM	Crankshaft, 10.2 mm	1
26	12385	STL	Ring, Retaining, Bearing	1
27	15710	STL	Bearing Outer, Ball	1
31	549726	—	<i>Cap, Vented with O-Ring (rain cap)</i>	1
32	547961	RTP	Cap, Oil Filler with O-Ring	1
33	14179	NBR	O-Ring, Oil Filler Cap-70D	1
37	92241	PC	Gauge, Oil with Gasket-80D	1
38	44428	NBR	Gasket, Flat, Oil Gauge-80D	1
48	44842	NY	Plug, Drain	1
49	14179	NBR	O-Ring, Drain Plug-70D	1
52	833820	SSSS	Pin, Guide (See Tech Bulletin 122)	2
53	833819	AL	Crankcase (See Tech Bulletin 122)	1
64	16948	CM	Pin, Crosshead	3
65	834203	SSTO	Rod, Plunger (See Tech Bulletin 124)	3
69	126259	STCP R	Washer, Oil Seal	3
70	25461	NBR	Seal, Oil Crankcase	3
90	831290	CC	Plunger, Ceramic (M20 x 18)	3
100	44869	PVDF	Retainer, Seal	3
106	547683	NBR	Seal, LPS with SS-Spring	3
	545192	FPM	Seal, LPS with SS-Spring	3
◆	546507	EPDM	Seal, LPS with SS-Spring	3
	76443	ST	Seal, LPS	3
110	833822	SS	Manifold, Inlet (See Tech Bulletin 122)	1
125	833824	SNG	Seal, HPS (See Tech Bulletin 122)	3
	76395	ST4	Seal, HPS with S	3
134	833821	D	Valve, Inlet (See Tech Bulletin 122)	3
	831400	SS	Valve, Inlet	3
135	543689	SS	Spacer	3
136	543690	SS	Spring, Inlet Valve	3
137	88575	S	Washer, Conical (M6)	3
138	543692	SS	Nut (M6)	3
152	549539	NBR	O-Ring, Adapter, Spacer, Inner-70D	3
	129977	FPM	O-Ring, Adapter, Spacer, Inner-70D	3
◆	129978	EPDM	O-Ring, Adapter, Spacer, Inner-70D	3
	994831	IPFE	O-Ring, Adapter, Spacer, Outer-70D	3
157	831289	SS	Adapter, Valve	3
159	23172	NBR	O-Ring, Adapter, Spacer, Outer-70D	3
	11377	FPM	O-Ring, Adapter, Spacer, Outer-80D	3
◆	46647	EPDM	O-Ring, Adapter, Spacer, Outer-80D	3
	703244	IPFE	O-Ring, Adapter, Spacer, Outer-75D	3
164	544293	SS	Seat	3
166	833825	D	Valve (See Tech Bulletin 122)	3
	543669	SS	Valve	3
167	543700	SS	Spring	3
168	44565	PVDF	Retainer, Spring	3
185	547705	SS	Manifold, Discharge	1
188	544701	S	Screw, HSH (M8 x 80)	6
255	30517	STZP R	Assy, Bolt Mount	1
285	80228	STL	Screw (M8 x 1.25 x 80) (Not Shown)	2
300	76265	NBR	Kit, Seal (Includes: 106, 125, 152, 159) STD (See Tech Bulletin 122)	1
	76955	FPM	Kit, Seal (Includes: 106, 125, 152, 159) .0110	1
◆	76996	EPDM	Kit, Seal (Includes: 106, 125, 152, 159) .0220	1
	76549	IPFE	Kit, Seal (Includes: 106, 125, 152, 159) .0770	1
310	76274	NBR	Discharge Valve (Includes: 152, 159, 164, 166, 167, 168) STD (See Tech Bulletin 122)	1
	76445	FPM	Discharge Valve (Includes: 152, 159, 164, 166, 167, 168) .0110	1
◆	76446	EPDM	Discharge Valve (Includes: 152, 159, 164, 166, 167, 168) .0220	1
	76597	IPFE	Discharge Valve (Includes: 152, 159, 164, 166, 167, 168) .0770	1
311	76278	NBR	Kit, Inlet Valve (Includes: 134-138, 152, 159) STD (See Tech Bulletin 122)	1
	76465	FPM	Kit, Inlet Valve (Includes: 134-138, 152, 159) .0110	1
◆	76466	EPDM	Kit, Inlet Valve (Includes: 134-138, 152, 159) .0220	1
	76587	IPFE	Kit, Inlet Valve (Includes: 134-138, 152, 159) .0770	1
	6107	—	Oil, Bottle (21 oz) ISO 68 Hydraulic (Fill to specified crankcase capacity prior to start up)	1

Italics are optional items. R Components comply with RoHS Directive. ◆ Silicone Oil/Grease required.

For additional technical information see www.catpumps.com/literature/tech-bulletins.

NOTE: Discard Key that may come standard with most motors and engines and use only the key included in Bolt kit.

MATERIAL CODES (Not Part of Part Number): AL=Aluminum CC=Ceramic CM=Chrome-Moly D=Acetal EPDM=Ethylene Propylene Diene Monomer

FPM=Fluorocarbon IPFE=I-Perfluoroelastomer NBR=Medium Nitrile (Buna-N) NY=Nylon PC=Poly Carbonate PVDF=Polyvinylidene Fluoride

RTP=Reinforced Composite S=304SS SNG=Special Blend (Buna) SS=316SS SSSS=440SS SSTO=316SS/Titanium Oxide

STL=Steel ST4=Special PTFE 4 STCP=Steel/Chrome Plated STZP=Steel/Zinc Plated TNM=Special High Strength

EXPLODED VIEW

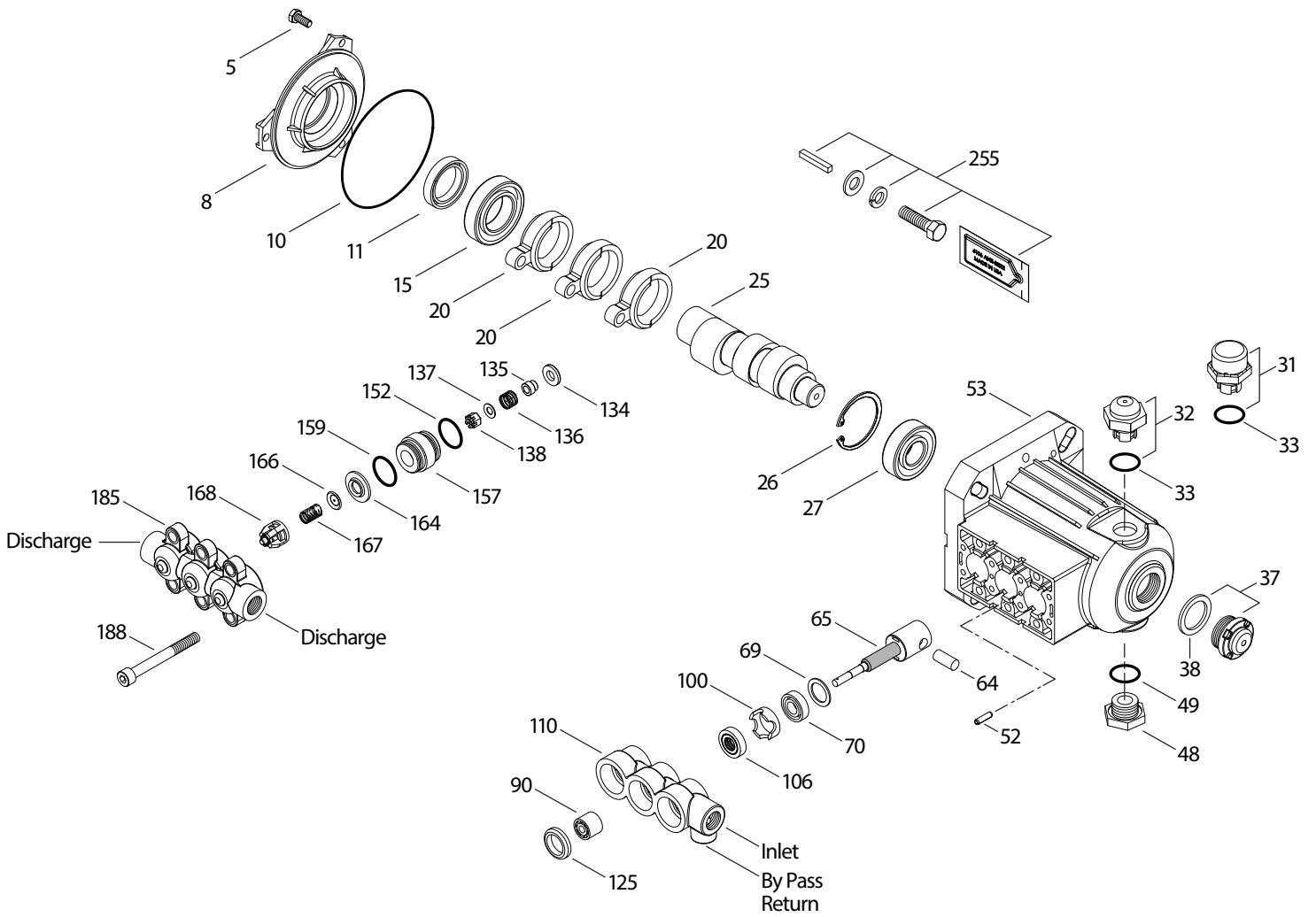

Model
2SFQ42SEEL
March 2020

MODEL	8105	8175	8110	8060	8062	8125/8125W
Dimension A	15.9	15.9	17.1	18.7	19.2	19.0
Dimension B	9.0	9.0	10.2	11.8	12.3	12.2
Dimension C	8.2	8.2	8.2	8.1	8.1	9.6
Dimension D	9.1	9.1	9.1	9.5	9.5	9.7

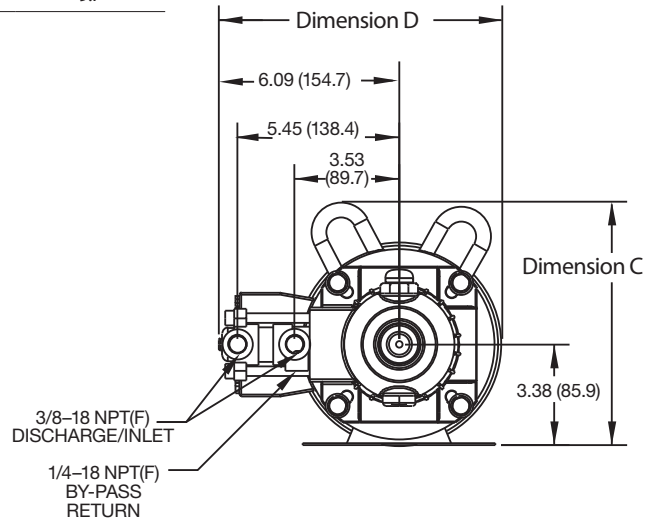
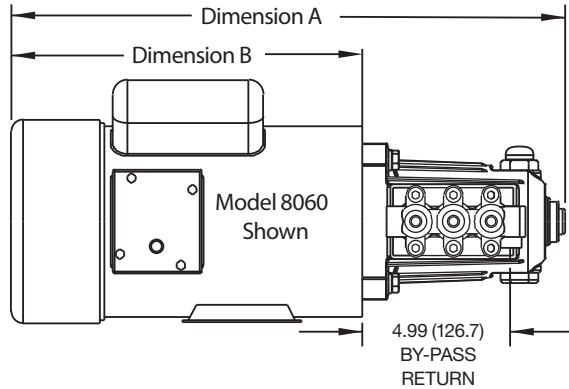

MOTOR SPECIFICATIONS

MODEL	8105	8175	8110	8060	8062	8125/8125W
HorsePower	0.5	0.75	1.0	1.5	2.0	2.5
Phase	Single	Single	Single	Single	Single	Single
RPM	1750	1745	1750	1725	1725	1750
Frame Size	56C TEFC	56C TEFC	56C TEFC	56C TEFC	56C TEFC	56HC TEFC
Shaft Diameter	5/8"	5/8"	5/8"	5/8"	5/8"	5/8"
Maximum Volts	115/208-230	115/208-230	115/208-230	115/230	115/230	115/230
Full Load Amps	7.4/3.6-3.7	10.6/5.2-5.3	14/6.8-7.0	14.0/7.0	17.0/8.5	20.8/10.4
Hertz	60	60	60	60	60	60
Service Factor	1.15	1.15	1.15	1.2	1.15	1.15
Max. Ambient Temp.	104° F	104° F	104° F	104° F	104° F	104° F
Capacitor Start	Yes	Yes	Yes	Yes	Yes	Yes
Thermal Overload-Manual Reset	No	Yes	No	Yes	Yes	No
Weight (lbs)	25	28	34	42	45.7	52.9

NOTE: Motor start-up AMPS may vary, then settle within FULL LOAD AMPS rating after initial run time.

★★ Before mounting pump on motor, apply P.N. 6106 Antiseize Lubricant to pump shaft.

Refer to Tech Bulletin 055 for instructions on removing pump from electric motor. For electric motor warranty consideration contact motor manufacturer's local authorized service center.

⚠ CAUTIONS AND WARNINGS

All high-pressure systems require a primary pressure regulating device (i.e. regulator, unloader) and a secondary pressure relief device (i.e. pop-off valve, relief valve). Failure to install such relief devices could result in personal injury or damage to pump or property. Cat Pumps does not assume any liability or responsibility for the operation of a customer's high-pressure system. Read all CAUTIONS and WARNINGS before commencing service or operation of any high-pressure system. The CAUTIONS and WARNINGS are included in each Service Manual and with each Accessory Data sheet. CAUTIONS and WARNINGS can also be viewed online at www.catpumps.com/dynamic-literature/cautions-and-warnings or can be requested directly from Cat Pumps.

WARRANTY

View the Limited Warranty on-line at www.catpumps.com/literature/cat-pumps-limited-warranty