

MODEL 2560 AND 2565 PLUNGER PUMP



NEW Product Available Fall 2020

2560
16 GPM | 3,000 PSI

2565
20 GPM | 2,500 PSI



Maximize Uptime with Cat Pumps

Cat Pumps products are accepted as an industry standard for high-pressure applications. Our dependable performance keeps equipment running to meet production requirements and tight schedules. Given its durability, the 2560 and 2565 can be used in a variety of mobile and industrial applications, such as hydroexcavating, jetting, hydroblasting, central cleaning, equipment washdown, among others.

Features:

- Crankcase crosshead area is concentric with 360° plunger rod support and features drilled-through oil port to lubricate front side of crosshead area, resulting in long, reliable drive-end performance.
- Two-coat electrostatic applied primer + epoxy paint finish provides a more durable finish than anodizing for better appearance and durability in outdoor environments.
- Flexible drive options:
 - Belt drive to engine or motor
 - Direct drive to hydraulic motor

Typical Applications:

- Hydroexcavating
- Water Jetting
- Surface Preparation
- Central Cleaning Systems
- Equipment Washdown
- High-Flow/Pressure Flushing
- Multi-Gun Systems

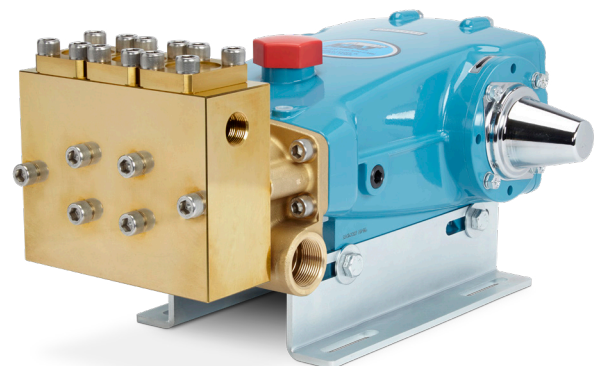

Specifications

	U.S. Measure	Metric Measure	
MODEL 2560	Flow	16 gpm	60.5 lpm
	Pressure	3,000 psi	207 bar
	RPM*	1,510 rpm	1,510 rpm
MODEL 2565	Flow	20 gpm	75.7 lpm
	Pressure	2,500 psi	172 bar
	RPM*	1,450 rpm	1,450 rpm

	U.S. Measure	Metric Measure
Inlet Pressure Range	Flooded to 30 psi	Flooded to 2.1 bar
Max Liquid Temp	140°F	60°C
Inlet Ports (2)	1 ¼" NPT(F)	1 ¼" NPT(F)
Discharge Ports (2)	¾" NPT(F)	¾" NPT(F)
Weight	95 lbs	42 kg
Dimensions	20.35 x 15.04 x 8.58"	517 x 382 x 218 mm

Dimensions

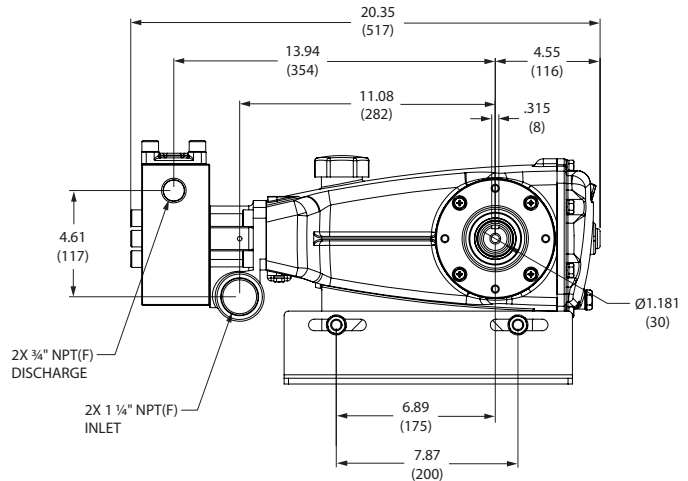
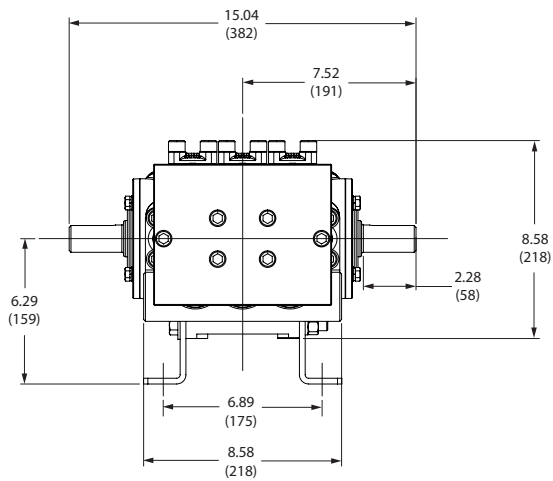

Popular Accessories



Pressure Regulator

PN 7542
1 – 21 GPM
800 – 4,000 PSI



Pop-Off Valve

PN 9940
0 – 25 GPM
1,000 – 4,000 PSI



Pressure Gauge

PN 6089
0 – 6,000 PSI



Filter

PN 7107.7
50 GPM Max
1 ¼" NPT(F)



Oil

PN 6107
21 oz. Bottle
Specially Formulated for
Extended Protection

Contact Cat Pumps for more information at info@catpumps.com or 763-780-5440



CAT PUMPS

1681 - 94TH LANE N.E. MINNEAPOLIS, MN 55449-4324
PHONE (763) 780-5440 — FAX (763) 780-2958
e-mail: info@catpumps.com
www.catpumps.com