

DATA SHEET

68 FRAME BLOCK-STYLE PLUNGER PUMP



Stainless Steel Models: **6801, 6811**

Flushed Models: **6801K, 6811K**

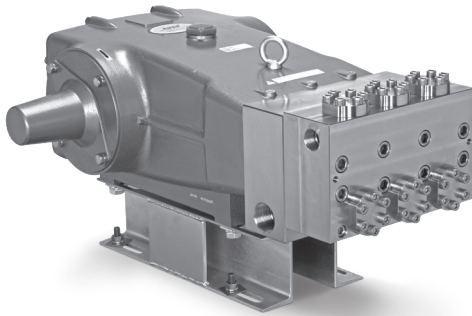

Model 6811 Shown
(Shaft protector and rails included)

FEATURES

- Triplex design offers high-efficiency and low-pulsation.
- V-packings and low-pressure seals are completely lubricated and cooled by pumped liquid.
- Models 6801K and 6811K provide an external flush for higher temperature or low-lubricity liquids.
- Wet-end is easily serviced without entering crankcase.
- Pump comes standard with NBR seals. Alternative seal materials are available for higher temperature or chemical compatibility.

COMMON SPECIFICATIONS

	U.S.	Metric
Inlet Pressure Range	Flooded to 50 psi	Flooded to 3.5 bar
Stroke	2.579"	65.5 mm
Crankcase Capacity	10 qts	9.46 l
Max. Liquid Temperature (NBR)	140° F	60° C

Alternate seals available for higher temperatures up to 200° F

Inlet Ports (2)	1 ½" NPT(F)	1 ½" NPT(F)
Flushing Ports (2) ("K")	½" NPT(F)	½" NPT(F)
Discharge Port (2)	1" NPT(F)	1" NPT(F)
Shaft Diameter	1.772"	45 mm
Weight	355 lbs	161 kg
Dimensions	29.68 x 23.98 x 11.97"	754 x 609 x 304 mm

SPECIFICATIONS

	U.S. Measure	Metric Measure
6801, 6801K		
Flow	15.0 gpm	57 lpm
Pressure Range	100–7000 psi	6.9–483 bar
Pump RPM*	630 rpm	630 rpm
Bore	0.984"	25 mm
6811, 6811K		
Flow	15.0 gpm	57 lpm
Pressure Range	100–5000 psi	6.9–345 bar
Pump RPM*	630 rpm	630 rpm
Bore	0.984"	25 mm

*Pump minimum is 100 RPM.

ALTERNATIVE SEAL CONFIGURATION

MATERIAL	SUFFIX CODE	MAXIMUM TEMPERATURE
NBR	—	160° F (71° C)
FPM	.0110	180° F (82° C)
EPDM	.0220	160° F (71° C)
IPFE	.0770	200° F (93° C)

See **Tech Bulletin 002** for inlet conditions and RPM at high-temperature.

$$\frac{\text{Rated gpm}}{\text{Rated rpm}} = \frac{\text{Desired gpm}}{\text{Desired rpm}}$$

$$\frac{\text{Desired gpm} \times \text{psi}}{1460} = \text{hp (Electric Brake)}$$

$$\frac{\text{Motor Pulley OD}}{\text{Pump rpm}} = \frac{\text{Pump Pulley OD}}{\text{Motor rpm}}$$

Refer to pump **Service Manual** for repair procedure and additional technical information.

PARTS LIST

ITEM	PART NUMBER								DESCRIPTION	QTY
	6801	MATL	6801K	MATL	6811	MATL	6811K	MATL		
5	89728	S	89728	S	89728	S	89728	S	Screw, HH (M10 x 40) (See Tech Bulletin 074)	8
6	15847	S	15847	S	15847	S	15847	S	Lockwasher (M10)	8
7	19934	S	19934	S	19934	S	19934	S	Washer, Flat (M10)	8
8	29443	AL	29443	AL	29443	AL	29443	AL	Cover, Bearing – Outer (See Tech Bulletin 118)	2
10	29444	NBR	29444	NBR	29444	NBR	29444	NBR	O-Ring, Bearing Cover–70D	2
11	11443	NBR	11443	NBR	11443	NBR	11443	NBR	Seal, Oil, Crankshaft	2
12	126594	STCP R	126594	STCP R	126594	STCP R	126594	STCP R	Washer, Shim (M120 x 0.3)	0–2
13	126595	STCP R	126595	STCP R	126595	STCP R	126595	STCP R	Washer, Shim (M120 x 0.5)	0–2
15	29441	STL	29441	STL	29441	STL	29441	STL	Bearing, Roller	2
16	29442	STL	29442	STL	29442	STL	29442	STL	Cover, Bearing – Inner	2
17	29444	NBR	29444	NBR	29444	NBR	29444	NBR	O-Ring, Bearing Cover–70D	2
20	126612	BBHS	126612	BBHS	126612	BBHS	126612	BBHS	Assembly, Connecting Rod (Includes: 21, 22) (See Tech Bulletin 074)	3
21	126560	STCP R	126560	STCP R	126560	STCP R	126560	STCP R	Washer, Locking	3
22	126593	STCP R	126593	STCP R	126593	STCP R	126593	STCP R	Washer, Shim (M10.5 x 1.5)	6
25	29440	FCM	29440	FCM	29440	FCM	29440	FCM	Crankshaft, Dual Shaft (M65.5)	1
32	43211	ABS	43211	ABS	43211	ABS	43211	ABS	Cap, Oil Filler	1
33	14177	NBR	14177	NBR	14177	NBR	14177	NBR	O-Ring, Filler Cap–70D	1
34	126743	STCP R	126743	STCP R	126743	STCP R	126743	STCP R	Bolt, Eye (M12) (For Lifting Pump Only)	1
38	129343	RBR	129343	RBR	129343	RBR	129343	RBR	Gasket, Flat Flex	1
39	27769	ABS	27769	ABS	27769	ABS	27769	ABS	Stick, Dip	1
40	89627	S	89627	S	89627	S	89627	S	Screw, HH (M10 x 30) (See Tech Bulletin 074)	8
41	15847	S	15847	S	15847	S	15847	S	Lockwasher (M10)	8
42	19934	S	19934	S	19934	S	19934	S	Washer, Flat (M10)	8
48	25625	STCP	25625	STCP	25625	STCP	25625	STCP	Plug, Drain (1/4" x 19 BSP)	1
49	23170	NBR	23170	NBR	23170	NBR	23170	NBR	O-Ring, Drain Plug–70D	1
50	29438	AL	29438	AL	29438	AL	29438	AL	Cover, Rear (See Tech Bulletin 118)	1
51	129386	NBR	129386	NBR	129386	NBR	129386	NBR	Gasket, Rear Cover	1
53	45303	AL	45303	AL	45303	AL	45303	AL	Crankcase (Includes: 34, 54) (See Tech Bulletin 118)	1
54	43282	S	43282	S	43282	S	43282	S	Pin, Guide	2
64	29481	CM	29481	CM	29481	CM	29481	CM	Pin, Crosshead	3
65	48735	SSZZ	48735	SSZZ	48735	SSZZ	48735	SSZZ	Rod, Plunger	3
69	126588	STCP R	126588	STCP R	126588	STCP R	126588	STCP R	Washer, Oil Seal	3
70	29454	NBR	29454	NBR	29454	NBR	29454	NBR	Seal, Oil Crankcase	3
75	43865	S	43865	S	43865	S	43865	S	Slinger Barrier	3
88	45676	S	45676	S	45676	S	45676	S	Washer, Keyhole (M16)	3
90	43866	CC	43866	CC	43866	CC	43866	CC	Plunger (M25 x 145)	3
95	89778	SS	89778	SS	89778	SS	89778	SS	Stud, Plunger Retainer (M10 x 135)	3
96	20189	PTFE	20189	PTFE	20189	PTFE	20189	PTFE	Backup Ring, Plunger Retainer	3
97	11345	NBR	11345	NBR	11345	NBR	11345	NBR	O-Ring, Plunger Retainer–70D	3
98	44085	SS	44085	SS	44085	SS	44085	SS	Gasket, Plunger Retainer	3
99	44084	SS	44084	SS	44084	SS	44084	SS	Retainer, Plunger (M10) (See Tech Bulletin 074)	3
100	703084	D	703084	D	703084	D	703084	D	Retainer, Seal	3
104	43875	NBR	43875	NBR	43875	NBR	43875	NBR	O-Ring, Adapter, Inlet–70D	3
105	701323	SS	701323	SS	701323	SS	701323	SS	Adapter, Inlet, LPS	3
106	44086	NBR	44086	NBR	44086	NBR	44086	NBR	Seal, LPS, with SS-Spring	3
107	44089	SS	44089	SS	44089	SS	44089	SS	Washer, LPS	3
110	701321	SS	—	—	701321	SS	—	—	Manifold Inlet, Block-Style	1
—	—	—	701322	SS	—	—	701322	SS	Manifold Inlet, Block-Style, Flushed (Models 6801K, 6811K)	1
111	701116	SS	701116	SS	701116	SS	701116	SS	Plug, Inlet Manifold [1 1/2" NPT(M)]	1
112	701632	NBR	701632	NBR	701632	NBR	701632	NBR	O-Ring, Spacer	6
113	701329	PTFE	701329	PTFE	701329	PTFE	701329	PTFE	Backup Ring, Spacer	6
114	701327	SS	701327	SS	701327	SS	701327	SS	Spacer, Inlet	3
117	89694	S	89694	S	89694	S	89694	S	Screw, HSH (M16 x 110) (See Tech Bulletin 074)	8
118	701077	SS	—	—	701077	SS	—	—	Plug [1/4" NPT(M)]	3
123	12391	NBR	12391	NBR	12391	NBR	12391	NBR	O-Ring, V-Packing Cylinder–70D	3
124	701324	SS	701324	SS	701324	SS	701324	SS	Cylinder, V-Packing	3
126	701325	SS	701325	SS	701325	SS	701325	SS	Adapter, Female	3
127	44610	STG	44610	STG	44610	STG	44610	STG	V-Packing	6
128	701326	SS	701326	SS	701326	SS	701326	SS	Adapter, Male	3
155	11379	NBR	11379	NBR	11379	NBR	11379	NBR	O-Ring, V-Packing Spacer, Inner–70D	3
156	28243	PTFE	28243	PTFE	28243	PTFE	28243	PTFE	Backup Ring, Spacer, Inner	3
157	701294	SS	701294	SS	701294	SS	701294	SS	Spacer, V-Packing	3
158	28243	PTFE	28243	PTFE	28243	PTFE	28243	PTFE	Backup Ring, Spacer, Outer	3
159	11379	NBR	11379	NBR	11379	NBR	11379	NBR	O-Ring, V-Packing Spacer, Outer–70D	3
160	44756	S	44756	S	44756	S	44756	S	Pin, Guide IMDM	2
162	21985	PTFE	21985	PTFE	21985	PTFE	21985	PTFE	Backup Ring, Seat	6
163	26089	NBR	26089	NBR	26089	NBR	26089	NBR	O-Ring, Seat–80D	6
164	44080	SS	44080	SS	44080	SS	44080	SS	Seat	6
166	44081	SS	44081	SS	44081	SS	44081	SS	Valve	6
167	44082	SS	44082	SS	44082	SS	44082	SS	Spring	6
168	44735	PVDF	44735	PVDF	44735	PVDF	44735	PVDF	Retainer, Spring	6
170	44794	SS	44794	SS	44794	SS	44794	SS	Washer, Retainer	6
171	44793	SS	44793	SS	44793	SS	44793	SS	Spring, Coil	6
172	15853	NBR	15853	NBR	15853	NBR	15853	NBR	O-Ring, Valve Plug–70D	6
173	20224	PTFE	20224	PTFE	20224	PTFE	20224	PTFE	Backup Ring, Valve Plug	6
174	701260	SS	701260	SS	701260	SS	701260	SS	Plug, Valve	6
175	87951	S	87951	S	87951	S	87951	S	Screw, HSH (M10 x 30) (See Tech Bulletin 074)	36
185	703206	SSD	703206	SSD	701320	SS	701320	SS	Manifold, Discharge, Block-Style	1
188	701279	S	701279	S	701279	S	701279	S	Screw, HSH (M12 x 100), Lower (See Tech Bulletin 074)	4
193	89694	S	89694	S	89694	S	89694	S	Screw, HSH (M16 x 110), Upper (See Tech Bulletin 074)	8
250	29445	AL	29445	AL	29445	AL	29445	AL	Protector, Shaft (Included with Pump) (See Tech Bulletin 118)	1
255	33243	STZP	33243	STZP	33243	STZP	33243	STZP	Kit, Mount (Included with Pump)	1
256	29649	STCP	29649	STCP	29649	STCP	29649	STCP	Washer, Slant (M16) Use for Adjustment Between Rail and Mounting Base	4
259	126604	STCP R	126604	STCP R	126604	STCP R	126604	STCP R	Rail, Box (Included with Pump)	2

EXPLODED VIEW

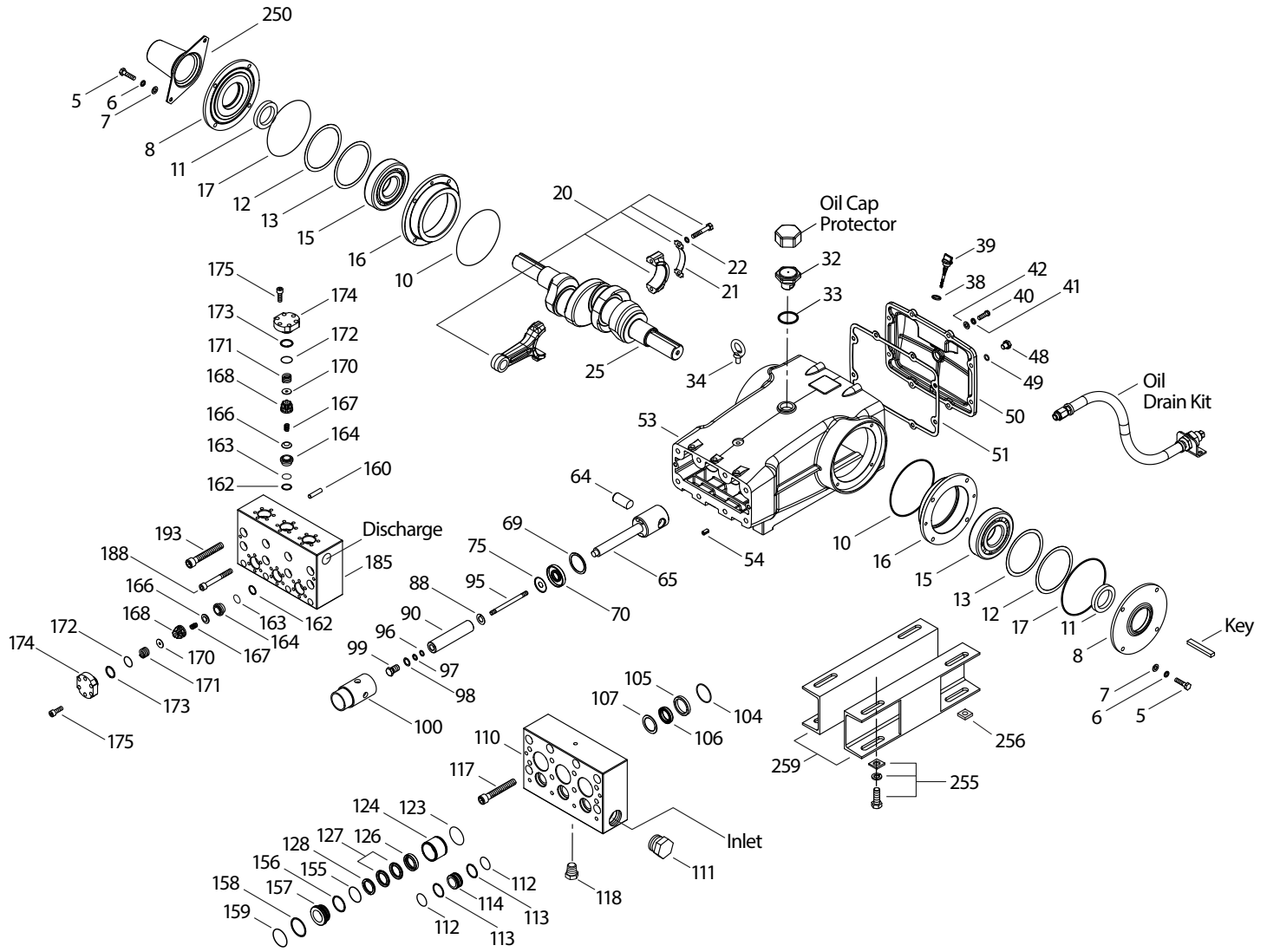

Models
Standard – 6801, 6811
Flushed – 6801K, 6811K
March 2021

OPTIONAL PARTS AND ACCESSORIES

PART	DESCRIPTION	QTY
43048	Key, M14 x 9 x 90	1
828710	Protector, Oil Cap with Foam Gasket	1
34314	Kit, Oil Drain	1
990014	Hub, "B", M45 with Keyway	1
819010	Assembly, Crankcase, Cast Iron Conversion	1
990663	Assembly, Flushing, 5 gal, 115V, 1.1 Amp, 1/2" NPT (Models 6801K, 6811K)	1

SERVICE PARTS

PART	DESCRIPTION	QTY
701648	Kit, Seal	1
34151	Kit, Valve	2
6105	Oil, Twin Pack (Two 2.5 Gal) ISO-68 Hydraulic	1
6119	Lubricant, Anti-Seize (2 oz) (See Tech Bulletin 095)	1
6124	Gasket, Liquid (3 oz)	1
910008	Head, Complete, Block-Style with NBR Seals and O-Rings (6801)	1
910000	Head, Complete, Block-Style with NBR Seals and O-Rings (6811)	1
910009	Head, Complete, Block-Style, Flushed, NBR Seals and O-Rings (6801K)	1
910005	Head, Complete, Block-Style, Flushed, NBR Seals and O-Rings (6811K)	1

Bold print part numbers are unique to a particular pump model. Italics are optional items.

R Components comply with RoHS Directive. For additional technical information see www.catpumps.com/literature/tech-bulletins.

MATERIAL CODES (Not Part of Part Number): ABS=ABS Plastic AL=Aluminum BBHS=Brass/High Strength CC=Ceramic CM=Chrome-Moly D=Acetal F=Cast Iron FCM=Forged Chrome-Moly NBR=Medium Nitrile (Buna-N) PE=Polyethylene PTFE=Pure Polytetrafluoroethylene PVDF=Polyvinylidene Fluoride RBR=Rubber S=304SS SS=316SS SSD=316SS/Duplex SSZZ=316SS/Zamak STCP=Steel/Chrome Plated STG=Special Blend PTFE White STL=Steel STZP=Steel/Zinc Plated

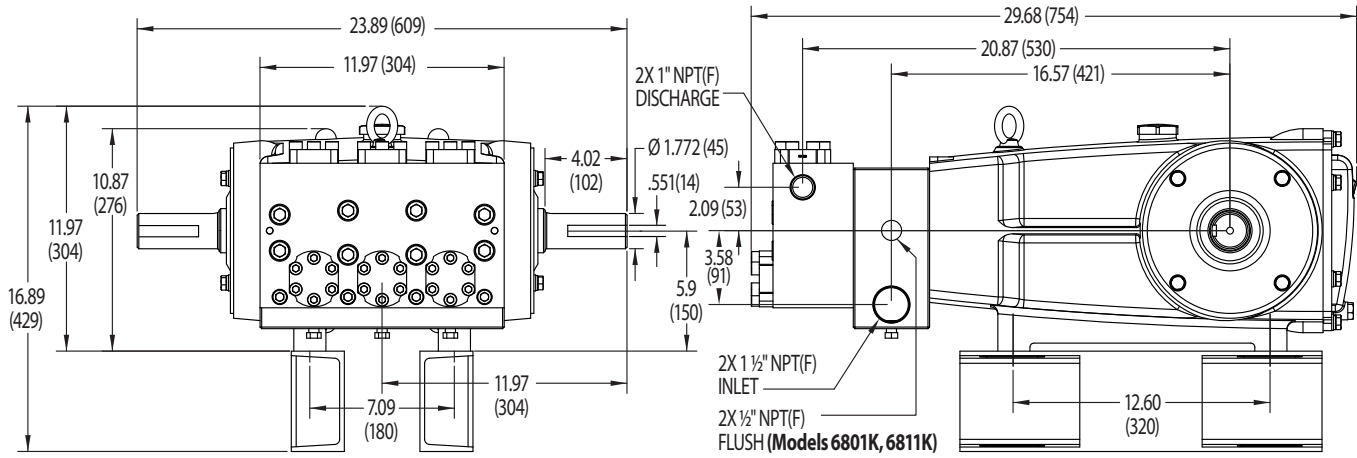

SEAL KITS One (1) seal kit required per pump

PUMP MODELS 6801, 6801K, 6811, 6811K	NBR (STD) 701648*	FPM (0.0110) 33710*	EPDM (0.0220) ♦ 702353*	IPFE (0.0770) 76788*		
ITEM (Included in Seal Kits)	PART NUMBER				DESCRIPTION	QTY
97	11345	11375	701490	702961	O-Ring, Plunger Retainer	3
104	43875	44826	701656	702977	O-Ring, Inlet Adapter	3
106	44086	45846	49196	701944	Seal, LPS, with SS-Spring	3
112	701632	701328	701973	703291	O-Ring, Inlet Spacer	6
113	701329	701329	701329	701329	Backup Ring, Spacer	6
123	12391	13266	701657	703481	O-Ring, V-Packing Cylinder	3
127	44610	44610	44610	703050	V-Packing	6
155	11379	14183	701491	702705	O-Ring, V-Packing Spacer, Inner	3
156	28243	28243	28243	28243	Backup Ring, Spacer, Inner	3
158	28243	28243	28243	28243	Backup Ring, Spacer, Outer	3
159	11379	14183	701491	702705	O-Ring, V-Packing Spacer, Outer	3

* Review material codes for individual items (STG generally may be used as alternate) ♦ Silicone oil/grease required

VALVE KITS Two (2) valve kits required per pump

PUMP MODELS 6801, 6801K, 6811, 6811K	NBR (STD) 34151	FPM (0.0110) 701798	EPDM (0.0220) ♦ 701799	IPFE (0.0770) 76171		
ITEM (Included in Valve Kits)	PART NUMBER				DESCRIPTION	QTY
162	21985	21985	21985	21985	Backup Ring, Seat	3
163	26089	11377	46647	703244	O-Ring, Seat	3
164	44080	44080	44080	44080	Seat	3
166	44081	44081	44081	44081	Valve	3
167	44082	44082	44082	44082	Spring	3
168	44735	44735	44735	44735	Retainer, Spring	3
170	44794	44794	44794	44794	Washer, Retainer	3
172	15853	11720	701481	702974	O-Ring, Valve Plug	3
173	20224	20224	20224	20224	Backup Ring, Valve Plug	3

♦ Silicone oil/grease required

⚠ CAUTIONS AND WARNINGS

All high-pressure systems require a primary pressure regulating device (i.e. regulator, unloader) and a secondary pressure relief device (i.e. pop-off valve, relief valve). Failure to install such relief devices could result in personal injury or damage to pump or property. Cat Pumps does not assume any liability or responsibility for the operation of a customer's high-pressure system. Read all CAUTIONS and WARNINGS before commencing service or operation of any high-pressure system. The CAUTIONS and WARNINGS are included in each Service Manual and with each Accessory Data sheet. CAUTIONS and WARNINGS can also be viewed online at www.catpumps.com/dynamic-literature/cautions-and-warnings or can be requested directly from Cat Pumps.

WARRANTY

View the Limited Warranty on-line at www.catpumps.com/literature/cat-pumps-limited-warranty

CAT PUMPS 1681 94th Lane N.E., Minneapolis, MN 55449-4324 P: (763) 780-5440 F: (763) 780-2958 E: techsupport@catpumps.com www.catpumps.com

©2021 Cat Pumps Inc. All rights reserved. All data contained in this document are based on the latest product information available at the time of publication. Cat Pumps reserves the right to make changes at any time without notice.