

# DATA SHEET

## DIRECT DRIVE PLUNGER PUMP



### Brass Model: **4DX29GUIF**

See page 4 for complete pump model number selection.

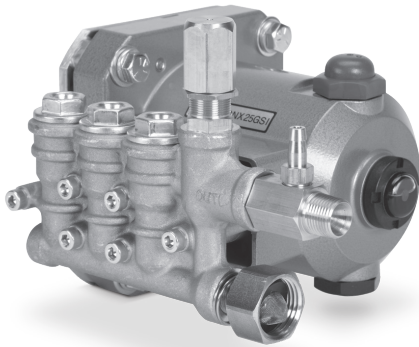

#### FEATURES

- Triplex plunger design ensures a smooth liquid flow.
- Compact flange mount permits easy, direct mounting to most gas engines\*
- Integral regulating unloader with built-in bypass ensures system pressure control and pump protection.
- Stacked stainless steel valve design promotes long-life and easy servicing.
- Fixed chemical injector aids in cleaning flexibility.
- Swivel garden hose fitting provides easy inlet connection.
- Includes crankcase oil.
- Pump comes standard with NBR seals. Alternative seal materials are available for higher temperature or chemical compatibility.

\*Gas Mounting Flange: SAE J609, Flange A, Extension 3 (3/4" Ø)  
 Shaft Length = 2.296", Pilot Ø = 1 5/8", B.C. Ø = 3 5/8" Thread = 5/16" - 24 UNC TAP

#### SPECIFICATIONS

	U.S. Measure	Metric Measure
Flow	2.9 gpm	11.0 lpm
Max. Discharge Pressure	2600 psi	179 bar
Pump RPM	3450 rpm	3450 rpm
Inlet Pressure Range	Flooded to 60 psi	Flooded to 4.1 bar
Max. Liquid Temperature (NBR)	140° F	60° C

#### Alternate Seals Available for Higher Temperatures up to 180° F

Bore	0.630"	16 mm
Stroke	0.232"	5.9 mm
Crankcase Capacity	8.5 oz	0.25 l
Inlet Port (1)	3/4" GHF	3/4" GHF
Manifold Inlet Port	3/8" NPT(F)	3/8" NPT(F)
Discharge Ports (1)	3/8" NPT(M)	3/8" NPT(M)
Accessory Port (1)	1/4" NPT(F)	1/4" NPT(F)
Shaft Diameter (Hollow)	3/4"	19.0 mm
Weight	10.7 lbs	4.9 kg
Dimensions	8.03 x 7.72 x 6.29"	204 x 196 x 160 mm

#### ALTERNATIVE SEAL CONFIGURATION

MATERIAL	SUFFIX CODE	MAXIMUM TEMPERATURE	
NBR	—	140° F	(60° C)
FPM	.0110	180° F	(82° C)

See **Tech Bulletin 002** for inlet conditions and RPM at high-temperature.

#### TORQUE AND HORSEPOWER REQUIREMENTS

	FLOW		PRESSURE				PUMP RPM
	GPM	LPM	PSI	BAR	PSI	BAR	
	1500	103	2000	138	2600	179	
Torque	2.9	11.0	4.5 ft-lbs		6.0 ft-lbs		3450
Horsepower*			3.8 hp		5.1 hp		

\*HP is for estimate only. Torque values of the engine at given rpm should be used to determine correct size of engine.

Consult engine manufacture for actual torque available at required speed.

**DETERMINING THE PROPER TORQUE**      Torque (ft-lbs) = 3.6 x  $\frac{\text{gpm} \times \text{psi}}{\text{rpm}}$

**DETERMINING THE REQUIRED HP**      Engine hp (Estimated) =  $\frac{\text{gpm} \times \text{psi}}{1140}$

**DETERMINING THE PUMP RPM**       $\frac{\text{Rated gpm}}{\text{Rated rpm}} = \frac{\text{Desired gpm}}{\text{Desired rpm}}$

Refer to pump **Service Manual** for repair procedure and additional technical information.

## EXPLODED VIEW

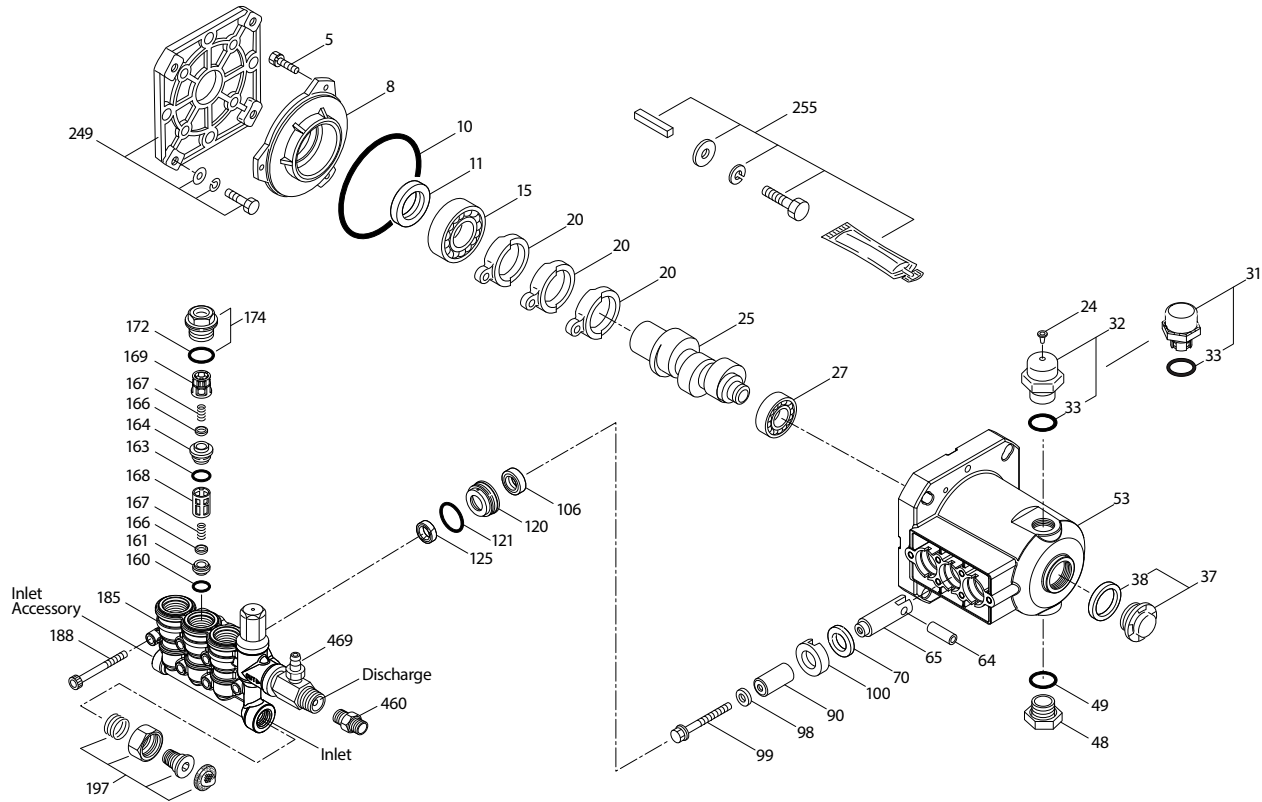

## PARTS LIST

ITEM	P/N	MATL	DESCRIPTION	QTY
5	549360	STCP R	Screw, HH (M6 x 14) (See Tech Bulletin 074)	3
8	547153	AL	Cover, Bearing	1
10	14041	NBR	O-Ring, Bearing Cover-70D	1
11	55337	NBR	Seal, Oil	1
15	14488	STL	Bearing Inner, Ball	1
20	547048	TNM	Rod, Connecting	3
24	549608	LDPE	Plug, Oil Cap	1
25	49884	CM	Crankshaft, 3450 RPM, 3/4", 5.9 mm	1
27	15710	STL	Bearing Outer, Ball	1
31	549726	—	Cap, Vented with O-Ring (Rain Cap)	1
32	547961	—	Cap, Vented with O-Ring	1
33	14179	NBR	O-Ring, Oil Filler Cap-70D	1
37	92241	PC	Gauge, Bubble Oil with Gasket (See Tech Bulletin 074)	1
38	44428	NBR	Gasket, Flat Flex, Oil Gauge-80D	1
48	44842	NY	Plug, Drain	1
49	14179	NBR	O-Ring, Drain Plug-70D	1
53	49801	AL	Crankcase	1
64	46229	CM	Pin, Crosshead	3
65	132190	BB	Rod, Plunger	3
70	47215	NBR	Seal, Oil	3
90	542403	CC	Plunger (M16 x 27)	3
98	46730	NBR	Washer, Seal-90D	3
	48394	FPM	Washer, Seal-90D	3
99	542405	S	Retainer, Plunger (M6 x 35) (See Tech Bulletin 074)	3
100	46233	D	Retainer, Seal	3
106	† 48222	NBR	Seal, LPS with S-Spring	3
	670019	FPM	Seal, LPS with S-Spring	3
	76089	ST2	Seal, LPS with SS-Spring	3
120	547357	BB	Case, Seal	3
121	13976	NBR	O-Ring, Seal Case-70D	3
	48522	FPM	O-Ring, Seal Case	3

ITEM	P/N	MATL	DESCRIPTION	QTY
125	46240	NBR	Seal, HPS with S	3
	76088	ST2	Seal, HPS	3
160	13965	NBR	O-Ring, Seat, Inlet-70D	3
	76656	FPM	O-Ring, Seat, Inlet-70D	3
161	545177	S	Seat, Inlet	3
163	19285	NBR	O-Ring, Seat, Discharge-70D	3
	14166	FPM	O-Ring, Seat, Discharge	3
164	545178	S	Seat, Discharge	3
166	46764	S	Valve	6
167	134579	S	Spring	6
168	543988	PVDF	Retainer, Spring, Inlet	3
169	49764	PVDF	Retainer, Spring, Discharge	3
172	142807	NBR	O-Ring, Plug-90D	3
	547743	FPM	O-Ring, Plug	3
174	547104	BB	Plug, Valve (M20 x 1.5) with O-Ring (See Tech Bulletin 074)	3
185	132192	FBB	Head, Manifold with Integral Regulator/Unloader Body	1
188	549357	STCP R	Screw, HSH (M6 x 60) (See Tech Bulletin 074)	6
196	22177	BBCP	Plug, Accessory (Not Shown)	1
197	941516	BB	Assembly, GH [3/8" NPT(M) x 3/4" GH(F)]	1
249	30520	—	Assembly, Adapter Mount	1
255	30516	STZP R	Assembly, Bolt Mount	1
300	33053	NBR	Kit, Seal (Includes: 98, 106, 121, 125) <b>Standard</b>	1
	76453	FPM*	Kit, Seal (Includes: 98, 106, 121, 125) <b>.0110</b>	1
310	76978	NBR	Kit, Valve (Includes: 160, 161, 163, 164, 166, 167, 168, 169, 172) <b>Standard</b>	1
	76463	FPM	Kit, Valve (Includes: 160, 161, 163, 164, 166, 167, 168, 169, 172) <b>.0110</b>	1
400	—	—	Regulator/Unloader, Integral (See Individual Parts)	1
460	107681	BB	Fitting, Discharge	1
469	7242	BB	Injector, Chemical, Fixed	1

*Italics are optional items.* [ ] Date of latest production change. R Components comply with RoHS Directive.

\*Review individual parts in each kit for material code identification. † Production parts are different than repair parts.

For additional technical information see [www.catpumps.com/literature/tech-bulletins](http://www.catpumps.com/literature/tech-bulletins). MATERIAL CODES (Not Part of Part Number): AL=Aluminum BB=Brass  
 BBCP=Brass Chrome Plated CC=Ceramic CM=Chrome-moly D=Acetal FBB=Forged Brass FPM=Fluorocarbon LDPE=Low Density Polyethylene NBR=Medium Nitrile (Buna-N) NY=Nylon  
 PC=Poly Carbonate PVDF=Polyvinylidene Fluoride S=304SS ST2=Special PTFE 2 STL=Steel STCP=Steel/Chrome Plated STZP=Steel/Zinc Plated TNM=Special High Strength

**NOTE:** Discard key which may come standard with most motors and **use only the key included in this kit.**

# INTEGRAL REGULATOR/UNLOADER

SPECIFICATIONS	U.S.	Metric
Flow	3.1 gpm	11.7 lpm
PSI Range	100–2600 psi	6.9–179 bar
Inlet Port	3/8" NPT(F)	3/8" NPT(F)
Discharge Port	3/8" NPT(M)	3/8" NPT(M)

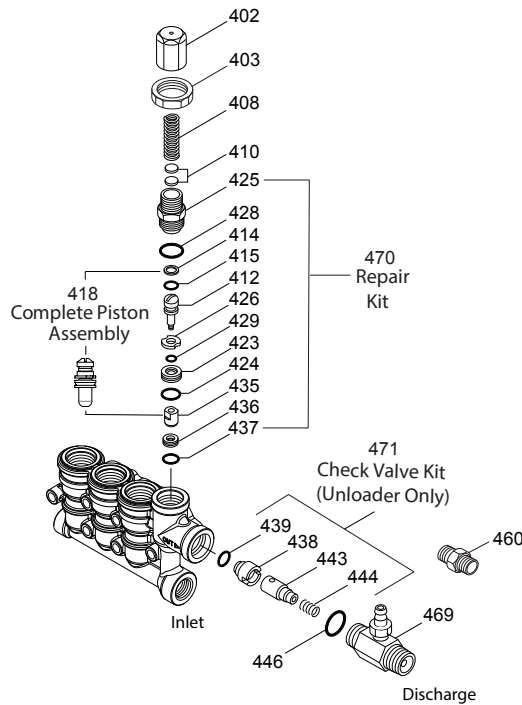

## PARTS LIST

ITEM	PN	MATL	DESCRIPTION	QTY
401	32088	NY	Handle, Adjustable (Not Shown)	1
402	46570	BB	Cap, Adjusting	1
403	45070	BB	Nut, Lock (M18 x 1)	1
408	33394	STZP R	Spring, Pressure	1
410	549352	STCP R	Retainer, Spring	2
412	46251	BB	Stem, Piston	1
414	—	PTFE	Backup Ring, Piston Stem	1
415	—	NBR	O-Ring, Piston Stem–70D	1
418	—	—	Assembly, Piston (Included In Repair Kit)	1
423	46249	BB	Retainer, Valve	1
424	—	NBR	O-Ring, Valve Retainer (Outer)–70D	1
425	46248	BB	Retainer, Piston	1
426	46250	S	Washer	1
428	—	NBR	O-Ring, Piston Retainer–80D	1
429	—	NBR	O-Ring, Valve Retainer (Inner)–80D	1
435	547969	S	Valve	1
436	548075	S	Seat	1
437	—	NBR	O-Ring, Seat–70D	1
438	—	NY	Seat, Check Valve	1
439	—	NBR	O-Ring, Seat, Check Valve–70D	1
443	—	BB	Valve, Check with O-Ring	1
444	—	S	Spring	1
446	—	NBR	O-Ring, Body–80D	1
460	107681	BB	Fitting, Discharge [3/8" NPT(M)]	1
468	76754	NBR	Kit, O-Ring (Includes: 414, 415, 424, 428, 429, 437) <b>Standard</b>	1
	76467	FPM	Kit, O-Ring (Includes: 414, 415, 424, 428, 429, 437) <b>.0110</b>	1
469	7242	BB	Injector, Chemical Fixed	1
470	76031	NBR	Kit, Repair (Includes: 418, 425, 428, 436, 437) <b>Standard</b>	1
	76468	FPM	Kit, Repair (Includes: 418, 425, 428, 436, 437) <b>.0110</b>	1
471	† 76146	NBR	Kit, Check Valve (Includes: 438, 439, 443, 444, 446) <b>Standard</b>	1
	76469	FPM	Kit, Check Valve (Includes: 438, 439, 443, 444, 446) <b>.0110</b>	1

*Italics are optional items.* R Components comply with RoHS Directive.

† Production parts are different than repair parts. MATERIAL CODES (Not Part of Part Number):

BB=Brass FPM=Fluorocarbon NBR=Medium Nitrile (Buna-N) NY=Nylon

PTFE=Pure Polytetrafluoroethylene S=304SS STCP=Steel/Chrome Plated

STZP=Steel/Zinc Plated

# MODEL 7242 FIXED CHEMICAL INJECTOR

SPECIFICATIONS	U.S.	Metric
GPM	3.0 gpm	11.4 lpm
Nozzle Orifice	2.0 mm	2.0 mm
Hose Barb	1/4"	1/4"
Tapped Barb	5/32" UNF	5/32" UNF
Inlet Port – Male	M18 x 1.0	M18 x 1.0
Discharge Port – Male	3/8" NPT(M)	3/8" NPT(M)
Weight	5.3 oz.	0.15 kg
Dimensions	2 x 1 x 1.75	52 x 25 x 45 mm

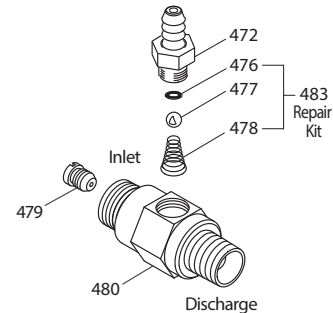

## PARTS LIST

ITEM	PN	MATL	DESCRIPTION	QTY
472	46630	BB	Barb	1
476	—	NBR	O-Ring, Barb–70D	1
	—	FPM	O-Ring, Barb	1
477	—	S	Ball	1
478	—	S	Spring	1
479	547971	BB	Orifice (2.0 mm)	1
480	—	BB	Body	1
483	76176	NBR	Kit, Repair (Includes: 476, 477, 478) <b>Standard</b>	1
	76476	FPM	Kit, Repair (Includes: 476, 477, 478) <b>.0110</b>	1

MATERIAL CODES (Not Part of Part Number):

BB=Brass FPM=Fluorocarbon NBR=Medium Nitrile (Buna-N) S=304SS

## CHEMICAL INJECTOR PERFORMANCE CHART

### Optional Special Ported Chemical Injector for Unloader Mounting

Orifice Size	Maximum Injecting Pressure	Maximum Chemical Draw	Pressure Drop Across Injector at System Pressure
2.0 mm	280 psi	35.3 oz/min	148 psi

Optimum performance of chemical injector occurs with a 35 ft. high-pressure hose and a minimum 3/8" I.D. The type of hose, extended lengths, reduced I.D. and fittings may create back pressures in excess of the low-pressure nozzle rating and prevent the injector from drawing chemical. **Deduct hose friction loss from above low psi nozzle. Consult Cat Pumps for assistance with other options.**

**CAUTION:** Deduct the pressure drop shown in the performance chart from your desired system pressure to arrive at the maximum high-pressure nozzle rating. This is essential to avoid over-pressurizing the pump.

## REGULATING DEVICE

An integral regulator or unloader with built-in bypass is part of the discharge manifold to provide system pressure regulation and pump protection. This unloader version includes a fixed chemical injector for chemical application. (See back page for proper model identifications)

## OPERATION

Pump should be purged of air before commencing with operation. Liquid must flow through the pump without discharge restriction to ensure full system pressure is reached. Install a pressure gauge close to the manifold head of the pump to assist in setting and periodically monitoring system pressure. Setting and adjusting the regulator or unloader pressure must be done with the system turned on. Start the system with the regulator or unloader backed off to the lowest pressure setting (counterclockwise direction). Squeeze the trigger and read the pressure on the gauge at the pump. Do not read pressure at the gun or nozzle.

If more pressure is desired, release the trigger, turn adjusting cap one quarter turn in a clockwise direction. Squeeze the trigger and read the pressure. Repeat this process until the desired system pressure is reached.

**NOTE:** Pressure is not set at the factory.

## SERVICE

The regulator or unloader should be serviced on the same schedule as the seals in the pump. Refer to 4DX Service Manual or start-up, servicing of seals and valves, torque requirements and diagnosis and maintenance chart.

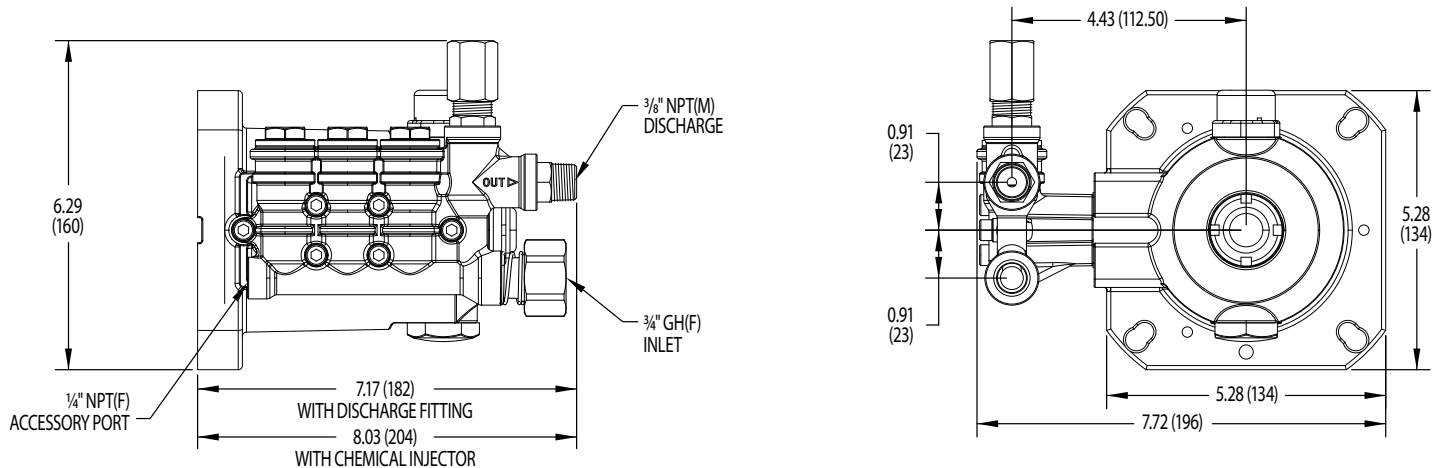

Base Model 4DX29GUIF

### 4DX Pump Series Selection Chart

Pump Series							Pump Flow/RPM	
4	D	X					GPM	RPM
			2	9			2.9	3450
					G		Gas, 3/4" Hollow Shaft	
						R	Regulating Device = Regulator	
						U	Regulating Device = Unloader	
						I	Fixed Chemical Injector	
						F	Garden Hose Fitting	
						.0110	FPM Seals	

#### Examples:

4DX29GUIF = 2.9 gpm (3450 rpm), Unloader, Chemical Injector, Garden Hose Inlet Fitting

#### ⚠ CAUTIONS AND WARNINGS

All high-pressure systems require a primary pressure regulating device (i.e. regulator, unloader) and a secondary pressure relief device (i.e. pop-off valve, relief valve). Failure to install such relief devices could result in personal injury or damage to pump or property. Cat Pumps does not assume any liability or responsibility for the operation of a customer's high-pressure system. Read all CAUTIONS and WARNINGS before commencing service or operation of any high-pressure system. The CAUTIONS and WARNINGS are included in each Service Manual and with each Accessory Data sheet. CAUTIONS and WARNINGS can also be viewed online at [www.catpumps.com/dynamic-literature/cautions-and-warnings](http://www.catpumps.com/dynamic-literature/cautions-and-warnings) or can be requested directly from Cat Pumps.

#### WARRANTY

View the Limited Warranty on-line at [www.catpumps.com/literature/cat-pumps-limited-warranty](http://www.catpumps.com/literature/cat-pumps-limited-warranty)

**CAT PUMPS** 1681 94th Lane N.E., Minneapolis, MN 55449-4324 P: (763) 780-5440 F: (763) 780-2958 E: [techsupport@catpumps.com](mailto:techsupport@catpumps.com) [www.catpumps.com](http://www.catpumps.com)

©2021 Cat Pumps Inc. All rights reserved. All data contained in this document are based on the latest product information available at the time of publication. Cat Pumps reserves the right to make changes at any time without notice.