

# DATA SHEET

## DIRECT DRIVE PLUNGER PUMPS



**Brass Electric Models:**

**2SF10ES, 2SF20ES, 2SF22ES, 2SF22ELS, 2SF29ELS, 2SF30ES, 2SF35ES**

**Brass Gas Models: 2SF30GS, 2SF35GS**

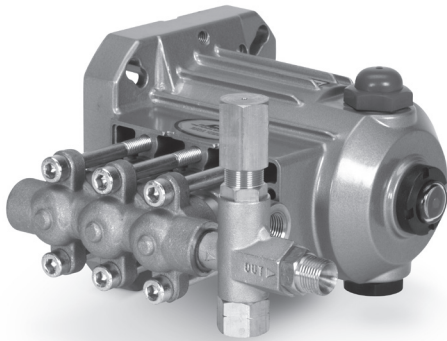

Model 2SF10ES Shown  
(Unloader included with pump)

### FEATURES

- Available in two configurations: hollow-shaft pump for direct mounting to gas engine or electric motor, or as motorized units.
- Includes regulating unloader to ensure system pressure control and pump protection.
- Pump comes standard with NBR seals. Alternative seal materials are available for higher temperature or chemical compatibility.

### COMMON SPECIFICATIONS

	U.S.	Metric
Inlet Pressure Range (Standard)	Flooded to 75 psi	Flooded to 5.2 bar
Inlet Pressure Range (High-Temp)	30–75 psi	2.1–5.2 bar
Max. Liquid Temperature (NBR)	160° F	71° C
<b>Alternate seals available for higher temperatures up to 180° F</b>		
Bore	0.708"	18 mm
Crankcase Capacity	10.1 oz	0.3 l
Inlet Port (1)	3/8" NPT(F)	3/8" NPT(F)
Discharge Port (1)	3/8" NPT(F)	3/8" NPT(F)
Discharge Port (1)	3/8" NPT(M)	3/8" NPT(M)
Bypass Port (1)	1/4" NPT(F)	1/4" NPT(F)
Weight (Pump Only)	10.6 lbs	4.8 kg
Dimensions (Pump Only)	9.13 x 6.65 x 6.50"	232 x 169 x 165 mm

SPECIFICATIONS	U.S. Measure		Metric Measure	
	<b>2SF10ES</b>		<b>2SF20ES</b>	
Flow	1.0 gpm	3.8 lpm	2.0 gpm	7.6 lpm
Max. Discharge Pressure	2000 psi	138 bar	2000 psi	138 bar
Pump RPM	3450 rpm	3450 rpm	3450 rpm	3450 rpm
Stroke	0.071"	1.8 mm	0.122"	3.1 mm
	<b>2SF22ELS</b>		<b>2SF22ES</b>	
Flow	2.2 gpm	8.3 lpm	2.2 gpm	8.3 lpm
Max. Discharge Pressure	2000 psi	138 bar	2000 psi	138 bar
Pump RPM	1725 rpm	1725 rpm	3450 rpm	3450 rpm
Stroke	0.248"	6.3 mm	0.132"	3.35 mm
	<b>2SF29ELS</b>		<b>2SF30ES</b>	
Flow	2.85 gpm	10.8 lpm	3.0 gpm	11.4 lpm
Max. Discharge Pressure	1500 psi	103 bar	1500 psi	103 bar
Pump RPM	1725 rpm	1725 rpm	3450 rpm	3450 rpm
Stroke	0.335"	8.5 mm	0.177"	4.5 mm
	<b>2SF30GS</b>			
Flow	3.0 gpm	11.4 lpm		
Max. Discharge Pressure	2000 psi	138 bar		
Pump RPM	3450 rpm	3450 rpm		
Stroke	0.189"	4.8 mm		
	<b>2SF35ES</b>		<b>2SF35GS</b>	
Flow	3.5 gpm	13.2 lpm	3.5 gpm	13.2 lpm
Max. Discharge Pressure	1500 psi	103 bar	2000 psi	138 bar
Pump RPM	3450 rpm	3450 rpm	3450 rpm	3450 rpm
Stroke	0.220"	5.6 mm	0.220"	5.6 mm

ES = **Electric** 3/4" hollow shaft with bolt mount, NEMA 56C

GS = **Gas** 3/4" hollow shaft with bolt mount and adapter.

Gas Mounting Flange: SAE J609, Flange A, Extension 3 (3/4" Ø)

Shaft Length = 2.296, Pilot Ø = 1 3/8", B.C. Ø = 3 3/8", Thread = 3/16"-24 UNC Tap

Refer to pump **Service Manual** for repair procedures and additional technical information.

### ALTERNATIVE SEAL CONFIGURATION

MATERIAL	SUFFIX CODE	MAXIMUM TEMPERATURE	
NBR	—	160° F	(71° C)
FPM	.0110	180° F	(82° C)
EPDM	.0220	160° F	(71° C)
HT	.3000	180° F	(82° C)

See **Tech Bulletin 002** for inlet conditions and RPM at high-temperature.

# PARTS LIST

ITEM	PART NUMBER	MATL	DESCRIPTION	MODEL USED	QTY
5	549360	STCP R	Screw, HH (M6 x 14) (See Tech Bulletin 074, 092)	All Models	3
8	547153	AL	Cover, Bearing, Inner (See Tech Bulletin 092)	All Models	1
10	14041	NBR	O-Ring, Bearing Cover-70D (See Tech Bulletin 092)	All Models	1
11	55337	NBR	Seal, Oil (See Tech Bulletin 092)	All Models	1
15	14488	STL	Bearing Inner, Ball	All Models	1
20	547046	TNM	Rod, Connecting	All Models	3
25	<b>831987</b>	CM	Crankshaft, 3450 RPM, 5/8", 1.8mm	2SF10ES	1
	<b>46109</b>	CM	Crankshaft, 3450 RPM, 5/8", 3.1mm	2SF20ES	1
	<b>45962</b>	CM	Crankshaft, 3450 RPM, 5/8", 3.35mm	2SF22ES	1
	<b>546334</b>	CM	Crankshaft, 3450 RPM, 3/4", 4.8mm	2SF30GS	1
	<b>44931</b>	CM	Crankshaft, 3450 RPM, 5/8", 4.5mm	2SF30ES	1
	<b>46119</b>	CM	Crankshaft, 3450 RPM, 5/8", 5.6mm	2SF35ES	1
	<b>46017</b>	CM	Crankshaft, 3450 RPM, 3/4", 5.6mm	2SF35GS	1
	<b>45160</b>	CM	Crankshaft, 1725 RPM, 5/8", 6.3mm	2SF22ELS	1
	<b>45914</b>	CM	Crankshaft, 1725 RPM, 5/8", 8.5mm	2SF29ELS	1
26	12385	STL	Ring, Retaining	All Models	1
27	15710	STL	Bearing Outer, Ball	All Models	1
31	549726	—	Cap, Vented with O-Ring (Rain Cap)	All Models	1
32	547961	RTP	Cap, Oil Filler with O-Ring	All Models	1
33	14179	NBR	O-Ring, Oil Filler Cap-70D	All Models	1
37	92241	PC	Gauge, Bubble Oil with Gasket-80D (See Tech Bulletin 074)	All Models	1
38	44428	NBR	Gasket, Flat Flex., Oil Gauge-80D	All Models	1
48	44842	NY	Plug, Drain [1/2" NPT(F)]	All Models	1
49	14179	NBR	O-Ring, Drain Plug-70D	All Models	1
53	547285	AL	Crankcase (See Tech Bulletin 092)	All Models	1
64	16948	CM	Pin, Crosshead	All Models	3
65	<b>44865</b>	SCP	Rod, Plunger	All Models except 2SF29ELS	3
	<b>45427</b>	SZZ	Rod, Plunger	2SF29ELS	3
69	126259	STCP R	Washer (M24)	All Models	3
70	25461	NBR	Seal, Oil	All Models	3
90	<b>45847</b>	CC	Plunger (M18 x 14)	All Models except 2SF29ELS	3
	<b>45429</b>	CC	Plunger (M18 x 16)	2SF29ELS	3
100	44869	PVDF	Retainer, Seal	All Models	3
106	44876	NBR	Seal, LPS with SS-Spring	All Models	3
	545192	FPM	Seal, LPS with SS-Spring	All Models	3
	◆ 546507	EPDM	Seal, LPS with SS-Spring	All Models	3
110	44874	BB	Manifold, Inlet	All Models	1
125	43245	SNG	Seal, HPS with S	All Models	3
	46652	HT	Seal, HPS High-Temperature 2-Piece with S-Support (See Tech Bulletin 073)	All Models	3
	76052	ST4	Seal, HPS with S	All Models	3
134	45854	S	Valve, Inlet	All Models	3
	33873	D	Valve, Inlet, High-Temperature	All Models	3
135	549520	S	Spacer, Inlet	All Models	3
136	44872	S	Spring, Inlet Valve	All Models	3
137	88575	S	Washer, Conical (M6)	All Models	3
138	27000	S	Nut, Slotted (M6) (See Tech Bulletin 074)	All Models	3
139	14158	S	Cotterpin (M1.6 x 10)	All Models	3
152	26089	NBR	O-Ring, Adapter, Inner-80D	All Models	3
	11377	FPM	O-Ring, Adapter, Inner-80D	All Models	3
	◆ 46647	EPDM	O-Ring, Adapter, Inner-80D	All Models	3
157	<b>44878</b>	BB	Discharge Valve Adapter	All Models except 2SF29ELS	3
	<b>45430</b>	BB	Discharge Valve Adapter	2SF29ELS	3
159	26089	NBR	O-Ring, Adapter, Outer-80D	All Models	3
	11377	FPM	O-Ring, Adapter, Outer-80D	All Models	3
	◆ 46647	EPDM	O-Ring, Adapter, Outer-80D	All Models	3
164	44881	S	Seat	All Models	3
166	43723	S	Valve	All Models	3
167	541062	S	Spring	All Models	3
168	44565	PVDF	Retainer, Spring	All Models	3
185	44879	BB	Manifold, Discharge	All Models	1
188	126762	STCP R	Screw, HSH (M8 x 75) (See Tech Bulletin 074)	All Models	6
197	941516	BB	GH Assembly, [ 3/8" NPT(M) x 3/4" GH(F)]	All Models	1
249	30520	—	Assembly, Adapter Mount, Gas	2SF30GS, 2SF35GS	1
255	30517	STZP R	Assembly, Bolt Mount	All Models	1

# EXPLODED VIEW

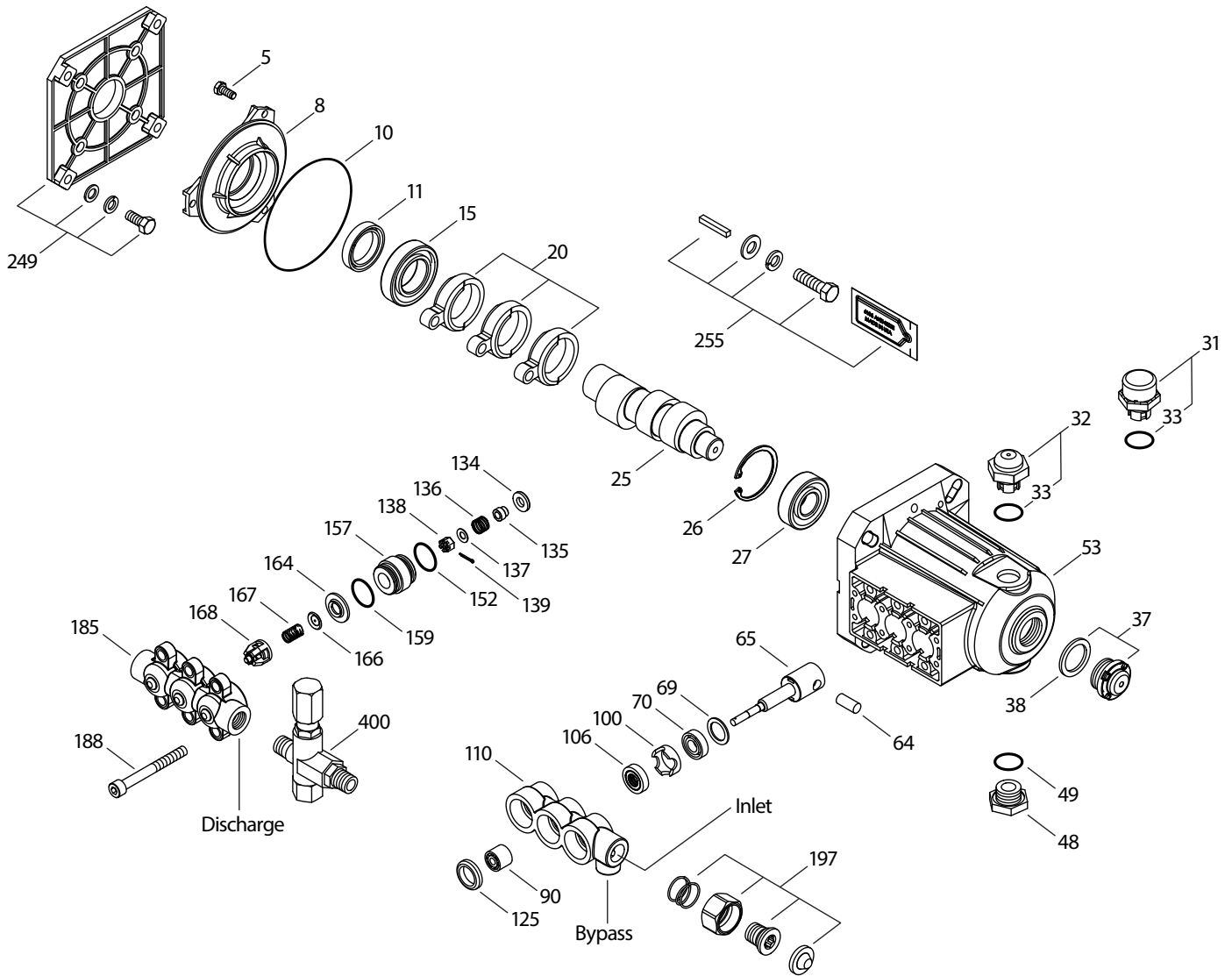

SF PLUNGER  
PUMP MODELS  
April 2021

ITEM	PART NUMBER	MATL	DESCRIPTION	MODEL USED	QTY
285	80228	STL	Screw (M8 1.25 x 80) (Not Shown)	All Models	2
300	34053	NBR	Kit, Seal (Includes: 106, 125, 139, 152, 159) <b>Standard</b>	All Models	1
	33953	HT	Kit, Seal High-Temperature (Includes: 106, 125, 134, 139, 152, 159) <b>.3000</b> (See Tech Bulletin 073)	All Models	1
	33453	FPM	Kit, Seal (Includes: 106, 125, 139, 152, 159) <b>.0110</b>	All Models	1
	◆ 30536	EPDM*	Kit, Seal (Includes: 106, 125, 139, 152, 159) <b>.0220</b>	All Models	1
310	34052	NBR	Kit, Discharge Valve (Includes: 152, 159, 164, 166, 167, 168) <b>Standard, .3000</b>	All Models	1
311	34668	NBR	Kit, Inlet Valve (Includes: 134-139, 152, 159) <b>Standard</b>	All Models	1
400	7500S	BB	Unloader, Regulating	All Models	1
—	6107	—	Oil, Bottle (21 oz) ISO 68 Hydraulic Fill to Specified Crankcase Capacity Prior to Start-Up)	All Models	1

**Bold print part numbers are unique to a particular pump model. Italics are optional items.**

[ ] Date of latest production change. R Components comply with RoHS Directive. \*Review individual parts in each kit for material code identification

◆ Silicone Oil /Grease Required. For additional technical information see [www.catpumps.com/literature/tech-bulletins](http://www.catpumps.com/literature/tech-bulletins).

NOTE: Discard Key which may come standard with most motors and engines and **use only the key included in this kit.**

MATERIAL CODES (Not Part of Part Number): AL=Aluminum BB=Brass CC=Ceramic CM=Chrome-Moly D=Acetal EPDM=Ethylene Propylene Diene Monomer FPM=Fluorocarbon HT=Hi-Temp (EPDM Alternative) NBR=Medium Nitrile (Buna-N) NY=Nylon PC=Poly Carbonate PVDF=Polyvinylidene Fluoride RTP=Reinforced Composite S=304SS SCP=304SS/Chrome Plated SNG=Special Blend (Buna) ST4=Special PTFE 4 STL=Steel STCP=Steel/Chrome Plated STZP=Steel/Zinc Plated SZZ=304SS/Zamak TNM=Special High Strength

Center raised pilot guide on the **Adapter Plate** assures proper alignment of pump and engine. Before mounting pump onto engine inspect engine for **recessed seal and bearing guide** to permit adapter to completely seat into recess and four bosses to be flush with engine face.

## EXPLODED VIEW

### 7500S UNLOADER SPECIFICATIONS

SPECIFICATIONS	U.S.	Metric
Flow Range	0.5–6.0 gpm	1.89–23 lpm
Pressure Range	100–2000 psi	6.9–138 bar
Inlet Port - Rear	3/8" NPT(M)	3/8" NPT(M)
Discharge Port - Front	3/8" NPT(M)	3/8" NPT(M)
Bypass Port - Bottom	3/8" NPT(F)	3/8" NPT(F)
Weight	14.4 oz	0.41 kg
Dimensions	3.0 x 1.0 x 4.25"	76.2 x 25.4 x 108 mm

### PARTS LIST

ITEM	P/N	MATL	DESCRIPTION	QTY
401	32088	NY	Handle, Black	1
402	540081	BB	Cap, Hex Adjusting	1
403	31047	BB	Nut, Lock	1
408	32094	STZP R	Spring, Pressure	1
410	107672	BB	Retainer, Spring	1
412	45694	S	Stem, Piston (M5)	1
414	—	PTFE	Backup Ring, Piston Stem	1
415	—	NBR	O-Ring, Piston Stem–70D	1
425	107673	BB	Retainer, Piston	1
428	—	NBR	O-Ring, Piston Retainer–70D	1
429	—	NBR	O-Ring, Body	1
430	—	PTFE	Backup Ring, Body	1
435	45696	BB	Valve and Ball Assembly (M5)	1
436	107680	S	Seat	1
437	—	NBR	O-Ring, Seat–70D	1
440	—	BB	Body	1
442	—	NBR	O-Ring, Bypass Fitting–70D	1
443	541060	BB	Valve, Check with NBR O-Ring	1
	549468	SS	Valve, Check with FPM O-Ring	1
	831515	SS	Valve, Check with EPDM O-Ring	1
444	45924	S	Spring, Check valve	1
446	—	NBR	O-Ring, Discharge Fitting–70D	1
455	45695	BB	Fitting, Bypass [3/8" NPT(F)]	1
460	107681	BB	Fitting, Discharge [3/8" NPT(M)]	1
465	7090	BB	Bypass Hose (15" x 3/8") (Not Shown)	1
466	7090.40	BB	Bypass Hose with Thermo Valve (Not Shown)	1
468	32097	NBR	Kit, O-Ring (Includes: 414, 415, 428, 429, 430, 437, 442, 446) <b>Standard, .3000</b>	1
	31627	FPM	Kit, O-Ring (Includes: 414, 415, 428, 429, 430, 437, 442, 446) <b>.0110</b>	1
◆	31959	EPDM	Kit, O-Ring (Includes: 414, 415, 428, 429, 430, 437, 442, 446) <b>.0220</b>	1

*Italics are optional items.* R Components comply with RoHS Directive.

◆ Silicone Oil /Grease Required. MATERIAL CODES (Not Part of Part Number):

BB=Brass EPDM=Ethylene Propylene Diene Monomer FPM=Fluorocarbon

NBR=Medium Nitrile (Buna-N) NY=Nylon PTFE=Pure Polytetrafluoroethylene S=304SS

SS=316SS STZP=Steel/Zinc Plated

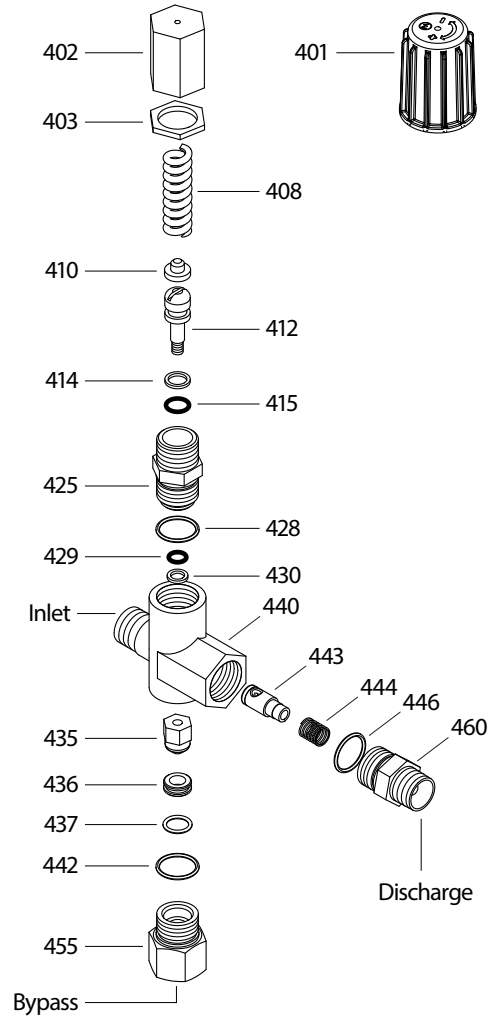

Refer to 7500S Data Sheet for repair procedures and additional technical information.

NOTE: By removing the check valve and spring, this unloader can function as a regulator.

## OPTIONAL CHEMICAL INJECTORS

### 7192, 7193, 7194 ADJUSTABLE, DOWN STREAM SPECIFICATIONS

		U.S.	Metric
Flow Range	7192	2-4 gpm	7.6-15 lpm
	7193	3-5 gpm	11.4-19 lpm
	7194	3-6 gpm	11.4-23 lpm
Orifice Size	7192	1.8 mm	1.8 mm
	7193	2.1 mm	2.1 mm
	7194	2.3 mm	2.3 mm
Maximum Pressure		3500 psi	241 bar
Maximum Temperature		195° F	90° C
Inlet Port		M18 x 1.0	M18 x 1.0
Discharge Port		3/8" NPT(M)	3/8" NPT(M)
Hose Barb		1/4"	1/4"
Weight		6.3 oz	0.18 kg
Dimensions		2.0 x 1.0 x 3.0"	50.8 x 25.4 x 76.2 mm

## PARTS LIST

ITEM	P/N	MATL	DESCRIPTION	MODEL	QTY USED
471	33949	NY	Handle, Adjustment	All	1
472	32941	BB	Barb, Adjustable	All	1
473	—	NBR	O-Ring, Hose Barb	All	1
474	33500	S	Spring, Retainer	All	1
475	33946	BB	Retainer, Ball/Seat	All	1
476	33504	FPM	O-Ring, Retainer	All	1
477	34620	SS	Ball, Seat 1/4"	All	1
478	33501	SS	Spring, Ball	All	1
479	<b>32372</b>	S	Injector Orifice (1.8 mm)	7192	1
	<b>32373</b>	S	Injector Orifice (2.1 mm)	7193	1
	<b>32374</b>	S	Injector Orifice (2.3 mm)	7194	1
480	—	BB	Body	All	1
481	33481	BBNY	Barb Assembly, Adjustable (Includes: 471, 472, 473, 474, 475, 476, 477, 478)	All	1
482	13969	NBR	O-Ring, Body-70D	All	1

*Italics are optional items.*

Material Codes (Not Part of Part No.): BB=Brass FPM=Fluorocarbon  
NBR=Medium Nitrile (Buna-N) NY=Nylon S=304SS SS=316SS

## PERFORMANCE CHART

Model	Desired Flow	Orifice Size (mm)	Low PSI Nozzle (Maximum Injecting Pressure Less Hose Friction Loss)	Maximum Chemical Draw (oz/min)	Pressure Drop Across Orifice (Deduct From High-Pressure)
7192	2 gpm	1.8	225 psi	60	150
7192	3 gpm	1.8	275 psi	60	300
7192	4 gpm	1.8	450 psi	60	500
7193	3 gpm	2.1	225 psi	54	150
7193	4 gpm	2.1	375 psi	54	250
7193	5 gpm	2.1	600 psi	54	400
7194	3 gpm	2.3	150 psi	50	125
7194	4 gpm	2.3	225 psi	50	220

Optimum performance of chemical injector occurs with a 35 ft high-pressure hose and a minimum 3/8" I.D. The type of hose, extended lengths, reduced I.D. and fittings may create back pressure in excess of the low-pressure nozzle rating and prevent the injector from drawing chemical. Deduct hose friction loss from the above PSI nozzle. Contact Cat Pumps for assistance with other options.

## EXPLODED VIEW

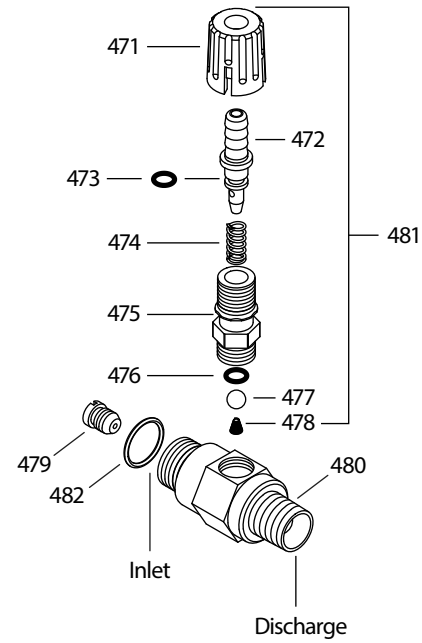

## CAUTION

Deduct the pressure drop shown in the performance chart from your desired system pressure to arrive at the maximum high-pressure nozzle rating. This is essential to avoid over-pressurizing the pump.

## EXAMPLE

$$\left[ \begin{array}{l} \text{System} - 4 \text{ GPM, } 2000 \text{ PSI} \\ \text{Injector} - 7193 \\ \text{Pressure Drop} - 250 \text{ PSI} \end{array} \right] = \left[ \begin{array}{l} \text{Low-Pressure Nozzle} - 375 \text{ PSI} \\ \text{Max. High-Pressure Nozzle} - 1750 \text{ PSI} \end{array} \right]$$

Flush system after chemical application to prevent clogging and to prolong life.

## TROUBLESHOOTING

No Chemical Draw:	<ul style="list-style-type: none"> <li>• Low-pressure nozzle sized for too high-pressure</li> <li>• Air leak in suction line</li> <li>• Worn injector orifice</li> </ul>
Leaking Around Adjusting Collar:	<ul style="list-style-type: none"> <li>• O-ring worn</li> <li>• Foreign material in injector</li> </ul>

## ELECTRIC MOTOR SPECIFICATIONS (60 hz, 1 hp)

Contact Cat Pumps for additional motor options including the 3 ph, 50 hz, frame sizes, etc.

### Model 8050

Horsepower	1.5
Shaft Diameter	5/8"
Maximum Volts	115/230
Full Load Amps	12.1
RPM	3450
Weight	32.1 lbs
Phase	Single
Frame Size	56C TEFC
Service Factor	1.15

### Model 8052

Horsepower	2.0
Shaft Diameter	5/8"
Maximum Volts	115/230
Full Load Amps	17.0/9.2–8.5
RPM	3450
Weight	32.5 lbs
Phase	Single
Frame Size	56C TEFC
Service Factor	1.15

### Model 8126

Horsepower	2.5
Shaft Diameter	5/8"
Maximum Volts	208–230/460
Full Load Amps	7.9–7.12/3.56
RPM	1750
Weight	63.0 lbs
Phase	Three
Frame Size	56C TEFC
Service Factor	1.15

### Model 8057

Horsepower	5.0
Shaft Diameter	3/4"
Maximum Volts	230
Full Load Amps	22.0
RPM	3450
Weight	40 lbs
Phase	Single
Frame Size	56C Open Drip
Service Factor	1.15

### Model 8060\*

Horsepower	1.5
Shaft Diameter	5/8"
Maximum Volts	115/208–230
Full Load Amps	13.6/7.5–6.8
RPM	1725
Weight	40 lbs
Phase	Single
Frame Size	56C TEFC
Service Factor	1.5

\* Use with ELS models or to reduce flow by 50% on standard models.

### Model 8062\*

Horsepower	2.0
Shaft Diameter	5/8"
Maximum Volts	115/230
Full Load Amps	18.8/9.4
RPM	1725
Weight	47 lbs
Phase	Single
Frame Size	56C TEFC
Service Factor	1.15

\* Use with ELS models or to reduce flow by 50% on standard models.

### Models 8125/8125W

Horsepower	2.5	2.2
Shaft Diameter	5/8"	5/8"
Maximum Volts	115/230	110/220
Full Load Amps	20.8/10.4	22/11
RPM	1750	1450
Weight	52.9 lbs	52.9 lbs
Phase	Single	Single
Hertz	60	50
Frame Size	56HC TEFC	56HC TEFC
Service Factor	1.15	1.15

### Common Motor Specifications

Maximum Ambient Temperature	104° F
Hertz	60 Hz
Capacitor Start	Yes
Thermal Overload Manual Rest	Yes

**Note:** Motor start-up AMPS may vary, then settle within FULL LOAD AMPS rating after initial run-in time.

Before mounting pump on motor, apply P.N. 6106 Antiseize Lubricant to pump shaft.

Refer to **Tech Bulletin 055** for instructions on removing pump from gas engine or electric motor.

# MOTOR DIMENSIONS

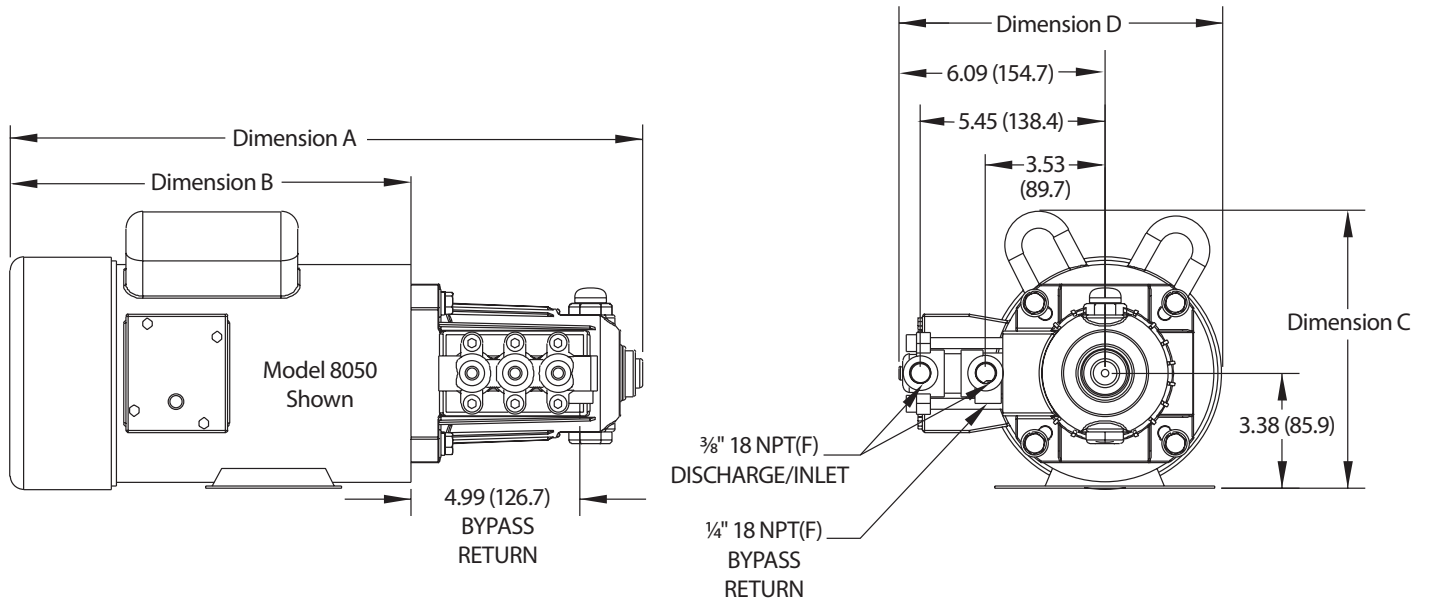

MODEL	8050	8052	8057	8060	8062	8125	8126
Dimension A	18.2 (462)	18.2 (462)	18.7 (475)	18.8 (477)	19.7 (500)	19.1 (485)	20.7 (525)
Dimension B	11.3 (287)	11.3 (287)	11.8 (300)	11.9 (302)	12.8 (325)	12.2 (310)	13.8 (350)
Dimension C	8.4 (213)	8.4 (213)	9.0 (228)	8.9 (226)	8.9 (226)	9.6 (243)	7.3 (185)
Dimension D	9.5 (241)	9.5 (241)	9.5 (241)	9.7 (246)	9.7 (246)	9.7 (246)	9.7 (246)

**DETERMINING THE REQUIRED HP**

$$\text{hp (Electric Brake)} = \frac{\text{gpm} \times \text{psi}}{1460}$$

$$\text{hp (Gas Brake)} = \frac{\text{gpm} \times \text{psi}}{1140}$$

For proper gas or diesel engine selection consult your engine supplier

## ELECTRIC HORSEPOWER REQUIREMENTS

FLOW		PRESSURE										PUMP RPM
GPM	LPM	PSI	BAR	PSI	BAR	PSI	BAR	PSI	BAR	PSI	BAR	
		700	48	1000	69	1200	83	1500	103	2000	138	
1.0	3.8	.48 hp		.68 hp		.82 hp		1.0 hp		1.4 hp		3450
2.2	8.3	1.1 hp		1.5 hp		1.8 hp		2.3 hp		3.0 hp		1725/3450
2.85	10.8	1.36 hp		2.0 hp		2.3 hp		2.9 hp		N/A		1725
3.0	11.4	1.4 hp		2.1 hp		2.5 hp		3.1 hp		4.1 hp		3450
3.5	13.2	1.67 hp		2.39 hp		2.87 hp		3.59 hp		N/A		3450

## UNLOADER TYPE

Each pump comes with a pressure-sensitive regulating unloader. This unloader will set system pressure. While in bypass the line pressure will drop to a low-pressure mode and then quickly build up to set system pressure when the system is back to full use.

## INSTALLATION AND START-UP

Install a pressure gauge close to the manifold head of the pump to assist in setting system pressure and to periodically monitor system pressure. Bypass line can be directed to the ground, a reservoir, redirected to the 1/4" NPT(F) port on bottom side of inlet manifold. If routing to pump inlet, use a 3/8" flexible hose and thermo valve.

**NOTE:** If not using a thermo valve **DO NOT EXCEED 6 MINUTES** in bypass.

**NOTE:** For high-temperature seal pumps **DO NOT USE THERMO VALVE**, use optional dual pressure switches and mechanical relays.

Pump should be purged of air before commencing with operation. Liquid must flow through the pump without discharge restriction to ensure full system pressure is reached.

Setting and adjusting the unloader pressure must be done with the system turned on. Start the system with the unloader backed off to the lowest pressure setting (counterclockwise direction). Squeeze the trigger and read the pressure on the gauge at the pump. Do not read pressure at the gun or nozzle. If more pressure is desired, release the trigger, turn adjusting cap one quarter turn in a clockwise direction. Squeeze the trigger and read the pressure. Repeat this process until the desired system pressure is reached. Thread locking nut up to adjusting cap.

**NOTE:** Pressure is not set at the factory.

## SERVICE

The unloader should be serviced on the same schedule as the seals in the pump. Refer to SF Plunger Pump Service Manual for start-up, servicing of seals and valves, torque requirements, diagnosis and maintenance chart.

### CAUTIONS AND WARNINGS

All high-pressure systems require a primary pressure regulating device (i.e. regulator, unloader) and a secondary pressure relief device (i.e. pop-off valve, relief valve). Failure to install such relief devices could result in personal injury or damage to pump or property. Cat Pumps does not assume any liability or responsibility for the operation of a customer's high-pressure system. Read all CAUTIONS and WARNINGS before commencing service or operation of any high-pressure system. The CAUTIONS and WARNINGS are included in each Service Manual and with each Accessory Data sheet. CAUTIONS and WARNINGS can also be viewed online at [www.catpumps.com/dynamic-literature/cautions-and-warnings](http://www.catpumps.com/dynamic-literature/cautions-and-warnings) or can be requested directly from Cat Pumps.

### WARRANTY

View the Limited Warranty on-line at [www.catpumps.com/literature/cat-pumps-limited-warranty](http://www.catpumps.com/literature/cat-pumps-limited-warranty)

---

**CAT PUMPS** 1681 94th Lane N.E., Minneapolis, MN 55449-4324 P: (763) 780-5440 F: (763) 780-2958 E: [techsupport@catpumps.com](mailto:techsupport@catpumps.com) [www.catpumps.com](http://www.catpumps.com)

©2021 Cat Pumps Inc. All rights reserved. All data contained in this document are based on the latest product information available at the time of publication. Cat Pumps reserves the right to make changes at any time without notice.