

DATA SHEET

35 FRAME PLUNGER PUMP

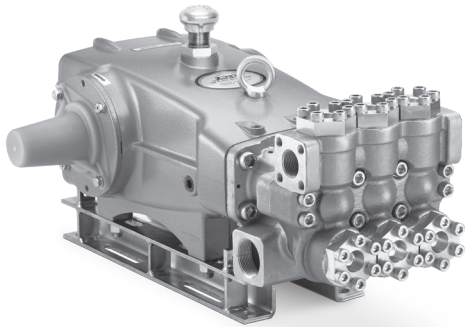

Stainless Steel **3501.44101**
Model:



Model 3501.44101 Shown
 (Shaft protector included, mounting rails sold separately)

FEATURES

- Field tested, high-pressure triplex pump configured for high-temperature TEG (triethylene glycol) applications up to 240° F/115° C. May be used in other high-temperature applications with liquids possessing adequate lubrication properties. Contact Cat Pumps for more information.
- Positive displacement technology delivers optimum energy efficiency.
- TEG* pump configuration option consists of following modifications:
 - FPM elastomers and O-ring material throughout the pump.
 - Chrome-plated steel vented oil filler cap assembly with brass adapter.
 - Stainless steel sight gauge assembly and aluminum adapter.
 - Aluminum seal retainers.
 - Special PTFE blended low-pressure seals and V-packings.

* TEG pump configuration is denoted by adding ".44101" to the end of the pump model.

SPECIFICATIONS	U.S. Measure	Metric Measure
Flow	10 gpm	38 lpm
Pressure Range	100–5000 psi	6.9–345 bar
Inlet Pressure Range	Flooded to 70 psi	Flooded to 4.8 bar
Maximum Liquid Temperature	240° F	115° C
Pump RPM*	915 rpm	915 rpm
Bore	0.787"	20 mm
Stroke	1.890"	48 mm
Crankcase Capacity	4.2 Qts	4 l
Inlet Ports (2)	1 1/2" NPT(F)	1 1/2" NPT(F)
Discharge Ports (2)	3/4" NPT(F)	3/4" NPT(F)
Pulley Mounting	Either Side	Either Side
Shaft Diameter	1.378"	35 mm
Weight	130 lbs.	59 kg
Dimensions	24.51 x 18.11 x 9.72"	623 x 460 x 247 mm

*Pump minimum is 100 RPM.

ELECTRIC HORSEPOWER REQUIREMENTS

FLOW		PRESSURE				PUMP RPM	
GPM	LPM	PSI	BAR	PSI	BAR		
10	38	3000	207	4000	275		5000
		Horsepower*				915	
		20.5 hp		27.4 hp			34.2 hp

*HP is for estimate only.

DETERMINING	Rated gpm	=	Desired gpm
THE PUMP RPM	Rated rpm	=	Desired rpm
DETERMINING	hp	=	gpm x psi
THE REQUIRED HP	(Electric Brake)	=	1460
DETERMINING	Motor Pulley OD	=	Pump Pulley OD
MOTOR PULLEY SIZE	Pump rpm	=	Motor rpm

Refer to pump **Service Manual** for repair procedure and additional technical information.

PARTS LIST

ITEM	PART NUMBER	MATL	DESCRIPTION	QTY
5	96049	S	Screw, HH Sems (M10x25) (See Tech Bulletin 125) (See Tech Bulletin 074)	8
8	134604	ALE	Cover, Bearing	2
9	815279	FBR	Shim, Split, 2-piece	2
10	76173	FPM	O-Ring, Bearing Cover-75D	2
11	76172	FPM	Seal, Oil, Crankshaft	2
15	29326	STL	Bearing, Roller	2
20	126725	BZ	Rod, Connecting Assembly (Includes: 21, 22, 23)	3
21	126749	STCP R	Washer, Locking (M10)	3
22	126593	STCP R	Washer, Flat (M10)	6
23	122045	STZP	Screw, HH (M10 x 55) (See Tech Bulletin 074)	6
25	29325	FCM	Crankshaft, Dual End (M48)	1
31	76411	BB	Adapter, 3/4" NPT(F)	1
32	992623	BB	Nipple, Close 3/4" NPT(M)	1
33	76331	STCP	Cap, Vented	1
34	126743	STCP R	Bolt, Eye (M12 x 1.75) (For Lifting Pump Only)	1
36	76792	SS	Gauge, Sight	1
37	76791	AL	Adapter, Sight	1
38	44428	NBR	Gasket, Flat Oil Gauge-80D	1
40	125753	S	Screw, HH Sems (M8 x 25) (See Tech Bulletin 074)	8
48	25625	STCP	Plug, Drain (1/4" x 19 BSP)	1
49	30322	FPM	O-Ring, Drain Plug	1
50	45936	ALE	Cover, Rear	1
51	76174	FPM	O-Ring, Cover-75D	1
53	134784	ALE	Crankcase Assembly (Includes: 34, 54)	1
54	27488	S	Pin, Guide	2
64	43864	CM	Pin, Crosshead	3
65	45118	SSZZ	Rod, Plunger	3
69	126587	STCP R	Washer, Oil Seal	3
70	44739	FPM	Seal, Oil, Crankcase	3
75	43506	S	Slinger, Barrier	3
87	49667	SSL	Collar	3
88	45675	S	Washer, Keyhole	3
90	43945	CC	Plunger (M20 x 145)	3
95	89779	S	Stud, Retainer (M7 x 123)	3
96	20184	PTFE	Backup Ring, Plunger Retainer	3
97	14161	FPM	O-Ring, Plunger Retainer-70D	3
98	44069	SS	Gasket, Plunger Retainer (M7)	3
99	44068	SS	Retainer, Plunger (M7) (See Tech Bulletin 074)	3
100	999324	AL	Retainer, Seal	3
104	44826	FPM	O-Ring, Adapter-70D	3
105	701344	SS	Adapter, LPS	3
106	76071	ST2	Seal, LPS with SS-Spring	3
107	44074	SS	Washer, LPS	3
110	45365	SS	Manifold, Inlet	1
112	14183	FPM	O-Ring, Inlet Manifold	3
117	44585	S	Screw, HSH (M14 x 40) (See Tech Bulletin 074)	4
123	13266	FPM	O-Ring, V-Packing Cylinder-70D	3
124	49666	SSL	Cylinder, V-Packing	3
126	44164	SS	Adapter, Female	3
127	76607	ST4	V-Packing	9
128	44165	SS	Adapter, Male	3
155	11719	FPM	O-Ring, V-Packing Spacer	3
156	28675	PTFE	Backup Ring, V-Packing Spacer	3
157	49668	SSL	Spacer, V-Packing	3
159	13264	FPM	O-Ring, V-Packing Cylinder-70D	3
162	21985	PTFE	Backup Ring, Seat	6
163	11377	NBR	O-Ring, Seat-80D	6
164	49671	SS	Seat	6
166	44081	SS	Valve	6
167	44082	SS	Spring	6
168	44735	PVDF	Retainer, Spring	6
170	44794	SS	Washer, Spring Retainer	6
171	44793	SS	Spring, Coil, Valve Plug	6
172	11720	FPM	O-Ring, Valve Plug-70D	6
173	20224	PTFE	Backup Ring, Valve Plug	6
174	45603	SS	Plug, Valve	6
175	87951	S	Screw, HSH (M10 x 30) (See Tech Bulletin 074)	36
185	49669	SSD	Manifold, Discharge	1
188	89981	S	Screw, HSH (M12 x 70) (See Tech Bulletin 074)	8
250	855042	NY	Protector, Shaft, with 2 Screws, Lockwashers and Washers (Included with Pump)	1

R Components comply with RoHS Directive.

*Review material codes for individual items (STG generally may be used as alternate). For additional technical information see www.catpumps.com/literature/tech-bulletins.

MATERIAL CODES (Not Part of Part Number): ALE=Aluminum Epoxy BB=Brass BZ=Bronze CC=Ceramic CM=Chrome-Moly FBR=Fiber FCM=Forged Chromemoly
 FPM=Fluorocarbon NBR=Medium Nitrile (Buna-N) NY=Nylon PE=Polyethylene PTFE=Pure Polytetrafluoroethylene PVDF=Polyvinylidene Fluoride S=304SS SS=316SS
 ST2=Special PTFE 2 ST4=Special PTFE 4 SSD=Duplex Stainless Steel SSL=316SS/Low Carbon SSZZ=316SS/Zamak STL=Steel
 STCP=Steel/Chrome Plated STZP=Steel/Zinc Plated

Repair kits and Parts, Optional Parts and Accessories listed on Page 4.

EXPLODED VIEW

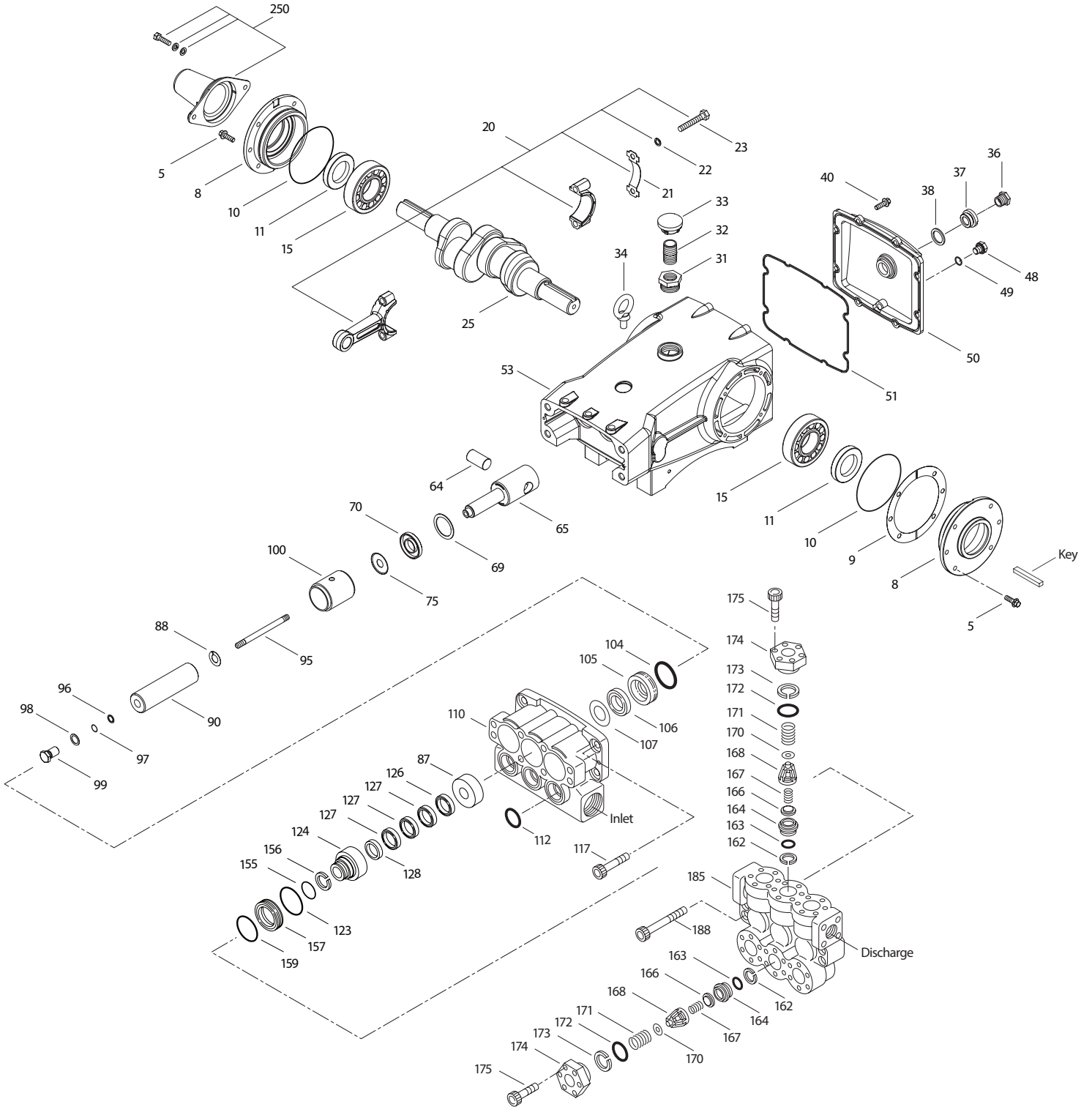

Model
Stainless Steel
3501.44101
June 2021

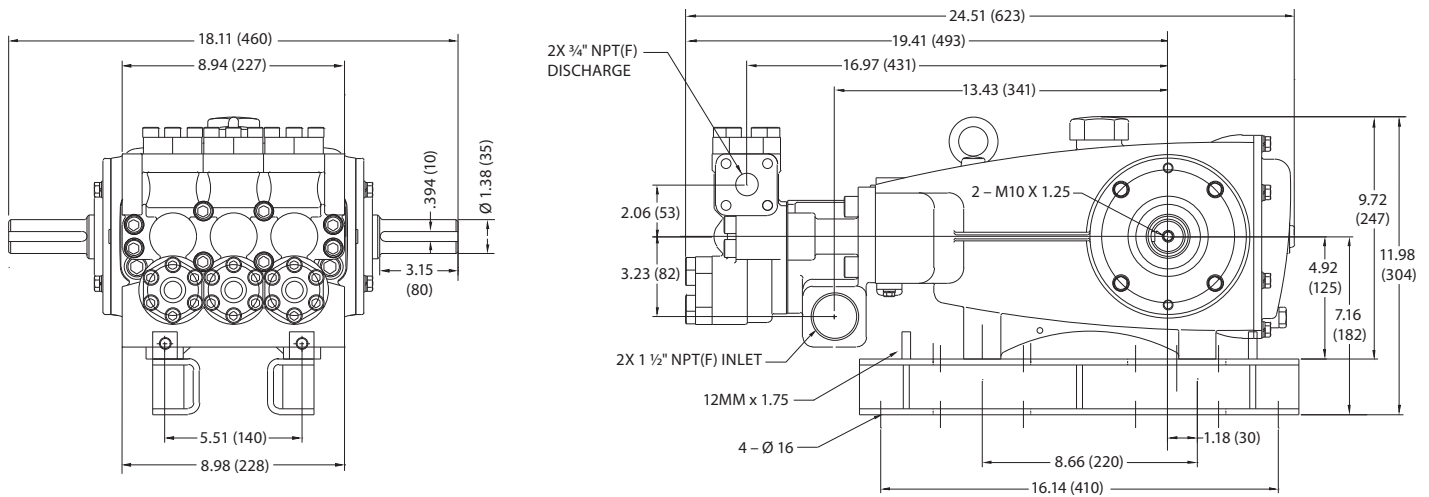

Model 3501.44101

REPAIR KITS AND PARTS

PART NUMBER	DESCRIPTION	QTY
77337	Kit, Seal (Includes Items 97, 104, 106, 112, 123, 127, 155, 156, 159)	1
76798	Kit, Valve (Includes Items 162, 163, 164, 166, 167, 168, 170, 172, 173)	2
6107	Oil, Bottle (21 oz) ISO 68 Hydraulic	7
34021	Key (M10 x 8 x 70)	1
6119	Lubricant, Anti Seize (2 oz)	1



7366

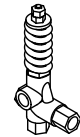

7536.1110



890711



6076

OPTIONAL PARTS AND ACCESSORIES

PART NUMBER	DESCRIPTION	QTY
7366	Regulator (Primary Pressure Control)	1
7536.1110	Relief Valve (Secondary Pressure Control)	1
890711	Pop-Off Valve (Secondary Pressure Control)	1
6076	Pressure Gauge	1
76514	Mounting Rail Assembly	1
76334	Kit, Oil Indicator (3/8" x 24") See Individual Data Sheet	1
34334	Kit, Oil Drain (3/8" x 24") See Individual Data Sheet	1
30696	Pliers (Reverse)	1
44050	Tool, Sight Gauge Removal	1

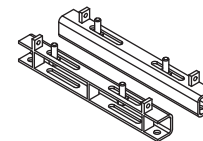

76514

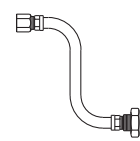

34334



6107

⚠ CAUTIONS AND WARNINGS

All high-pressure systems require a primary pressure regulating device (i.e. regulator, unloader) and a secondary pressure relief device (i.e. pop-off valve, relief valve). Failure to install such relief devices could result in personal injury or damage to pump or property. Cat Pumps does not assume any liability or responsibility for the operation of a customer's high-pressure system. Read all CAUTIONS and WARNINGS before commencing service or operation of any high-pressure system. The CAUTIONS and WARNINGS are included in each Service Manual and with each Accessory Data sheet. CAUTIONS and WARNINGS can also be viewed online at www.catpumps.com/dynamic-literature/cautions-and-warnings or can be requested directly from Cat Pumps.

WARRANTY

View the Limited Warranty on line at www.catpumps.com/literature/cat-pumps-limited-warranty

CAT PUMPS 1681 94th Lane N.E., Minneapolis, MN 55449-4324 P: (763) 780-5440 F: (763) 780-2958 E: techsupport@catpumps.com www.catpumps.com

©2021 Cat Pumps Inc. All rights reserved. All data contained in this document are based on the latest product information available at the time of publication. Cat Pumps reserves the right to make changes at any time without notice.