

DATA SHEET

PRESSURE SENSITIVE REGULATING UNLOADER



**Stainless Steel
Models:**

7531, 7533, 7536



Model 7531 Shown

FEATURES

- Maintains full system pressure while running in bypass without full load on pump.
- Senses pressure built up from downstream flow changes and bypasses flow to protect pump from overpressure.
- Minimum pressure fluctuations with alternating use of multiple guns.
- Multiple ports provide for convenient mounting.
- Color coded spring allows for easy identification and simple change from one model to another.
- Standard unloaders are fitted with NBR O-rings. Optional O-rings are available for higher temperature and chemical compatibility.
 - FPM – .0110 (7531.0110)
 - FPM – .0110 (7533.0110)
 - FPM – .0110 (7536.0110)

SPECIFICATIONS

	U.S.	Metric
7531		
Flow Range	1–21 gpm	3.8–80 lpm
Pressure Range	400–2200 psi	27.5–152 bar
7533		
Flow Range	1–21 gpm	3.8–80 lpm
Pressure Range	800–4000 psi	55–275 bar
7536		
Flow Range	1–21 gpm	3.8–80 lpm
Pressure Range	3000–6000 psi	207–414 bar

COMMON SPECIFICATIONS

	U.S.	Metric
Maximum Operating Temperatures:		
Standard NBR O-Rings	140° F	60° C
Stand. NBR O-Rings (Intermittent)	195° F	90° C
Optional FPM O-Rings	240° F	116° C
Inlet Ports (2)	½" NPT(F)	½" NPT(F)
Discharge Port	½" NPT(F)	½" NPT(F)
Bypass Port	½" NPT(F)	½" NPT(F)
Weight	2.9 lbs	1.31 kg
Dimensions	8.75 x 3.75 x 1.75"	223 x 96 x 45 mm

Use only at above specifications to ensure proper unloader life and performance.

 These Pressure-Sensitive Regulating Unloaders can be converted to Secondary Relief Valves. See page 4 for Relief Valve conversion.

Read all CAUTIONS and WARNINGS before commencing service or operation of any high-pressure system

SELECTION

These pressure-sensitive regulating unloaders are designed for systems with single or multiple pumps, solenoid (gate) valves, nozzles, standard or "weep" guns.

Note: For multiple-pump systems, it is best to use a pressure regulator, not a pressure-sensitive regulating unloader.

These pressure-sensitive regulating unloaders should meet both the desired system flow (combined nozzle flow rate requirement) and the desired system pressure.

Note: Operation below the minimum flow of the unloader causes the unloader to cycle. Operation above the maximum flows of the unloader causes premature unloader wear, cycling and prevents attaining desired system pressure.

INSTALLATION

These unloaders operate properly when mounted in any direction, however, it is preferred to keep the plumbing to a minimum and the hex adjusting nut easily accessible. The best mounting location is directly on the pump discharge manifold.

There are two (2) inlet connections on these unloaders. Both are 1/2" NPT(F) ports and are located on the short extension side and bottom. An arrow and the word IN is cast into the body indicating the direction of flow. Liquid from the manifold discharge goes through these connections.

The discharge connection is a 1/2" NPT(F) hex fitting. An arrow and the word OUT is cast into the body indicating the direction of flow. Discharge plumbing for the spray guns, solenoid (gate) valves or nozzles are connected to this port.

The bypass connection is a 1/2" NPT(F) port located on the side of the body. The word BY-PASS is cast into the body. Bypass liquid is directed out of this port and can be routed to a reservoir (preferred method), a drain or to the pump inlet.

OPERATION

These pressure-sensitive regulating unloaders hold established system pressure in the discharge line when the trigger gun is closed or solenoid (gate) valve is closed or the nozzle is clogged, thus bypassing all unrequired flow. Squeezing the trigger gun or opening the solenoid (gate) valve will close the bypass and return to established system pressure.

PRESSURE ADJUSTMENT

1. Setting and adjusting the unloader pressure must be done with the system "on."
2. Start the system with unloader backed off to the lowest pressure setting (counterclockwise direction).
3. Squeeze the trigger and read the pressure on the gauge at the pump.
Note: Do not read the pressure at the gun or nozzle.
4. If more pressure is desired, release the trigger, turn hex adjusting nut one quarter turn in clockwise direction.
5. Squeeze the trigger and read the pressure.
6. Repeat this process until desired system pressure is attained.
7. Once the desired system pressure is reached, stop turning the hex adjusting nut.

Note: Pressure is not set at the factory.

Notice: A minimum bypass flow of 5% of the unloader rated flow capacity is required for proper unloader performance. If the entire flow is directed through the nozzle (zero bypass) the "cushioning" feature of the bypass liquid is eliminated and the unloader can prematurely wear or malfunction.

8. If desired system pressure cannot be reached, review TROUBLESHOOTING chart.
9. When servicing existing systems, follow adjustment procedures as stated above.

Note: A secondary pressure safety relief device (i.e. pop-off valve, safety valve) should be used along with this pressure-sensitive regulating unloader. Final adjustment for the relief valve should relieve at 200 psi above the system operating pressure.

Note: By removing the check valve and spring, these unloaders can function as a secondary relief valve.

🔧 See page 4 for Relief Valve conversion.

TYPICAL UNLOADER INSTALLATION

1. Pressure Gauge
2. Relief Valve
Shown as a secondary Relief Valve
3. Pulsation Dampener
4. Pressure Sensitive Regulating Unloader
5. Triplex Plunger Pump

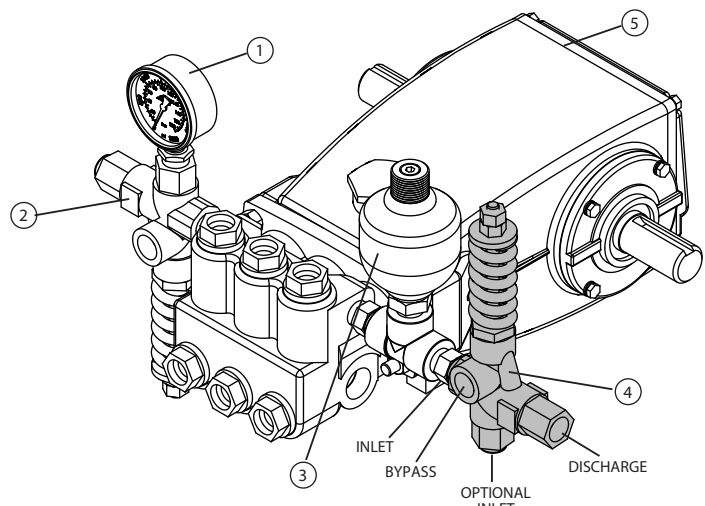

Read all CAUTIONS and WARNINGS before commencing service or operation of any high-pressure system

SERVICING

Disassembly

1. Disconnect bypass, discharge and inlet plumbing from unloader.
2. Remove unloader from pump.
3. Secure body of unloader in a vise with hex adjusting nuts facing up.
4. Remove discharge fitting and O-ring, spring and check valve with O-ring.
5. Examine check valve and discharge fitting for wear, spring for wear or fatigue, and O-rings for cuts or wear. Replace as needed.

Note: While the discharge fitting is removed, inspect sealing area where the check valve makes contact within the internal body of the unloader for grooves, pitting and wear. If damage is found, stop the repair and replace with complete new unloader. No damage is found, proceed with disassembly.

6. Remove two (2) hex adjusting nuts by turning in a counterclockwise direction.
7. Remove spring retainer and spring.
8. Examine spring and spring retainer for scale build up, fatigue or wear and replace as needed.
9. Use wrench to unthread and remove piston retainer and piston stem together from main unloader body.
10. Examine piston stem and piston retainer for scale build up, scoring, pitting and wear, and replace as needed. Examine O-rings and backup rings for cuts or wear. Replace as needed.
11. Remove unloader body from vise and reposition in vise with bottom inlet port facing up.
12. Remove inlet fitting with O-ring, seat, spring and ball.
13. Remove unloader body from vise and reposition in vise with bottom inlet port facing down.
14. Drive out seat and O-ring from the top side.
15. Examine seat, seat spring and ball for scale build up, scoring and wear and replace as needed. Examine O-rings for cuts or wear. Replace as needed.

Reassembly

1. Remove unloader body from vise and reposition in vise with bottom inlet port facing up.
2. Lubricate and install O-ring onto outside diameter of seat.
3. Place seat with O-ring into unloader body with small inside diameter hole facing up.
4. Place ball onto seat and then spring.
5. Lubricate and install O-ring onto inlet fitting. Thread in inlet fitting by hand and tighten.
6. Remove unloader body from vise and reposition in vise with bottom inlet fitting facing down.
7. Lubricate and install O-ring and then backup ring over threaded end of piston stem small diameter groove.
8. Install backup ring, O-ring and then backup ring on opposite end of threaded piston stem. Lubricate all parts.
9. Lubricate and install O-ring onto piston retainer.
10. Place threaded end of piston retainer over the threaded end of the piston stem.
11. Place piston retainer and piston stem assembly into unloader body with threaded end of piston stem facing up. Thread piston retainer into unloader body by hand and tighten with wrench.
12. Apply Loctite® 242® to the bottom threads of the piston stem.
13. Hand thread one (1) hex nut onto piston stem and tighten with wrench.
14. Place spring over piston stem, followed by positioning the spring retainer onto spring with stepped surface facing down.
15. Hand thread two (2) hex nuts onto piston stem.
16. Lubricate O-ring on check valve. Insert check valve with O-ring facing into unloader body. Place spring onto check valve.
17. Lubricate O-ring on discharge fitting. Hand thread into unloader body and tighten with wrench.
18. Remove unloader from vise.
19. Re-install unloader onto pump.
20. Reconnect bypass, discharge and inlet plumbing to unloader.
21. Proceed to PRESSURE ADJUSTMENT.

Loctite and 242 are registered trademarks of the Henkel Corporation.

TROUBLESHOOTING

Unloader cycles	<ul style="list-style-type: none"> • Worn O-ring or check valve • Fitting leaking downstream • O-ring in gun worn
Liquid leaking from bottom	<ul style="list-style-type: none"> • O-ring for seat or inlet fitting cut or worn
Liquid leaking from middle	<ul style="list-style-type: none"> • O-ring for piston worn or cut
Unloader will not come up to pressure	<ul style="list-style-type: none"> • Not properly sized for system pressure • Foreign material in unloader • Piston O-rings worn • Nozzle worn or too large • Adjusting nuts not properly set
Extreme pressure spikes	<ul style="list-style-type: none"> • Adjusting handle turned completely into unloader • Restricted bypass or no bypass • System flow exceeds unloader rating

PRESSURE READING

Approximate pressure reading at gauge	Gauge between pump/unloader	Gauge between unloader/gun-nozzle-valve
System in operation (Gun open)	System pressure	System pressure
System in bypass (All guns, valves closed)	Low pressure 0–150 psi	System Pressure +200 psi

PARTS LIST

ITEM	DESCRIPTION	MODEL NUMBER			MAT	QTY
		7531	7533	7536		
401	Handle, Adjustment	33045	33045	33045	NY	1
403	Nut, Hex Adjusting (M10)	—	—	—	S	3
408	Spring—White (400–2200 psi)	32323	—	—	STL	1
	Spring—Blue (800–4000 psi)	—	32324	—	STL	1
	Spring—Black (3000–6000 psi)	—	—	32344	STL	1
410	Retainer, Spring	30119	30119	30119	BB	1
412	Stem, Piston	32339	32339	32339	S	1
		34586	34586	34586	SS	1
414	Backup Ring, Piston Stem	—	—	—	PTFE	1
415	O-Ring, Piston Stem—90D	—	—	—	NBR	1
425	Retainer, Piston	39055	39055	39055	S	1
426	Pin, Piston Lock	32326	32326	32326	S	1
428	O-Ring, Piston Retainer—85D	32926	32926	32926	NBR	1
429	O-Ring, Piston Stem	—	—	—	NBR	1
430	Backup Ring, Piston Stem	—	—	—	PTFE	2
434	Spring, Seat	32325	32325	32325	S	1
435	Ball and Seat Assembly	32327	32327	32327	S	1
437	O-Ring, Seat—90D	—	—	—	NBR	1
439	O-Ring, Inlet Fitting—85D	32926	32926	32926	NBR	1
440	Body	—	—	—	S	1
441	O-Ring, Check Valve	—	—	—	NBR	1
443	Valve, Check with NBR O-Ring	32338	32338	32338	S	1
444	Spring, Check Valve	32332	32332	32332	S	1
446	O-Ring, Discharge Fitting—85D	32926	32926	32926	NBR	1
455	Fitting, Inlet [½" NPT(F)]	32342	32342	32342	S	1
460	Fitting, Discharge [½" NPT(F)]	32345	32345	32345	S	1
462	Plug, Inlet	—	—	—	S	1
468	Kit, (Includes: 414, 415, 428, 429, 430, 437, 439, 441, 446)	32346	32346	32346	NBR	1
—	Kit, (Includes: 414, 415, 428, 429, 430, 437, 439, 441, 446)	33346	33346	33346	FPM	1

Bold print part numbers are unique to a particular model.

Italics are optional items.

MATERIAL CODES (Not Part of Part Number): BB=Brass FPM=Fluorocarbon NBR=Medium Nitrile (Buna-N) NY=Nylon PTFE=Pure Polytetrafluoroethylene S=304SS SS=316SS STL=Steel

EXPLODED VIEW

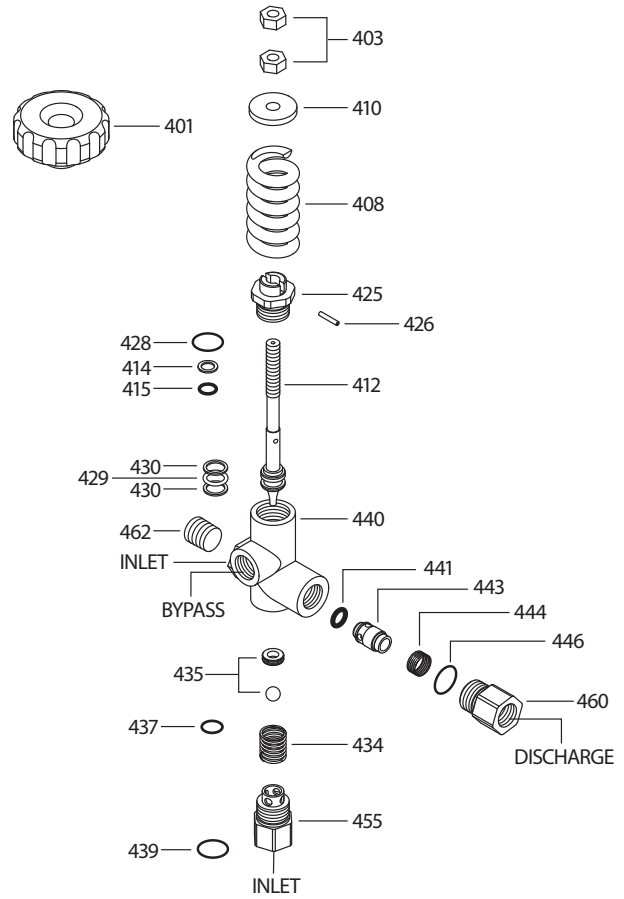

REGULATING UNLOADER TO RELIEF VALVE CONVERSION

The 7531, 7533 and 7536 Pressure-Sensitive Regulating Unloaders are typically used as a primary pressure regulating device. They can be converted to a Relief Valve to be used as a secondary pressure relief device by removing the discharge check valve, O-ring and spring.

Unloader PN	Modifications	Converted Relief Valve PN	
7531	Remove parts 441, 443, 444	7531.100 (NBR Seals)	7531.1110 (FPM Seals)
7533		7533.100 (NBR Seals)	7533.1110 (FPM Seals)
7536		7536.100 (NBR Seals)	7536.1110 (FPM Seals)

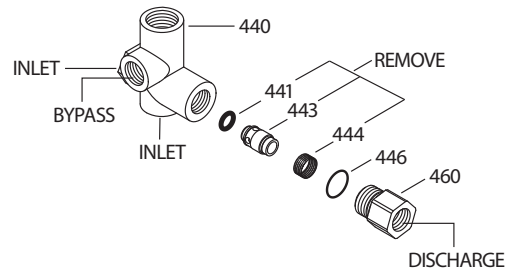

CAUTIONS AND WARNINGS

All high-pressure systems require a primary pressure regulating device (i.e. regulator, unloader) and a secondary pressure relief device (i.e. pop-off valve, relief valve). Failure to install such relief devices could result in personal injury or damage to pump or property. Cat Pumps does not assume any liability or responsibility for the operation of a customer's high-pressure system. Read all CAUTIONS and WARNINGS before commencing service or operation of any high-pressure system. The CAUTIONS and WARNINGS are included in each Service Manual and with each Accessory Data sheet. CAUTIONS and WARNINGS can also be viewed online at www.catpumps.com/dynamic-literature/cautions-and-warnings or can be requested directly from Cat Pumps.

WARRANTY

View the Limited Warranty online at www.catpumps.com/literature/cat-pumps-limited-warranty

CAT PUMPS 1681 94th Lane N.E., Minneapolis, MN 55449-4324 P: (763) 780-5440 F: (763) 780-2958 E: techsupport@catpumps.com www.catpumps.com

©2021 Cat Pumps Inc. All rights reserved. All data contained in this document are based on the latest product information available at the time of publication. Cat Pumps reserves the right to make changes at any time without notice.