

DATA SHEET

PULSATION DAMPENER



Stainless Steel
Model: 6032



SPECIFICATIONS	U.S.	Metric
Maximum flow	10 gpm	37.8 lpm
Working pressure range	100–10,000 psi	6.9–689 bar
Precharge	6000 psi	414 bar
Operating temperature range	32–180° F	0–82° C
Volume	15 cu. in	0.25 l
Safety factor	4/1	4/1
Bladder material	NBR	NBR
Body material	SS	SS
Port size (2)	½" NPT(F)	½" NPT(F)
Diameter	6.0"	152.4 mm
Length	6.4"	162.6 mm
Weight	22.2 lbs	10.1 kg

FEATURES

- Nitrogen precharged to eliminate moisture and bladder deterioration.
- Larger diaphragm design provides greater pulsation reduction for smoother performance and longer system component life.
- 316 stainless steel resists wear and abrasion caused by corrosive environments.
- Flow through design utilizes interchangeable inlet and discharge ports.

ORDERING INFORMATION

Model 6032 is precharged to 6000 psi at the factory. Contact Cat Pumps to specify the following:

1. No precharge (remove factory pressure)
2. A precharge different than 6000 psi.

Add .800 to part number (i.e., 6032.800) and specify desired precharge when ordering.

Note: A handling charge will apply.

SHIPMENT REGULATIONS

- Precharged pulsation dampeners are defined as hazardous articles. **These articles use the proper shipping name of "Articles, Pressurized, Hydraulic" and use the identification number of "UN3164."**
- Uncharged pulsation dampeners require no special handling and can be shipped via standard shipping methods.
- All domestic shipments of hazardous articles must follow Department of Transportation CFR 49, parts 100 to 185 regulations (DOT).
- International shipments of hazardous articles must follow either International Air Transport Association regulation (IATA) or International Maritime Dangerous Goods Codes (IMDG).

INSTALLATION INSTRUCTIONS

⚠ WARNING

Do not charge pulsation dampeners with oxygen. Oxygen may cause an explosion causing personal injury, death or property damage.

1. Use nitrogen only when charging pulsation dampeners, DO NOT USE OXYGEN.
2. Use proper charging tools to charge pulsation dampeners.
3. Charge pulsation dampener within specifications stated on data sheet to ensure proper pulsation dampenings and prevent failure of bladder.

SELECTION: Pulsation dampener should be selected to match the flow and pressure requirements of the system, and satisfy the liquid compatibility.

INSTALLATION: Pulsation dampeners must be mounted downstream and in-line with the pump discharge manifold to optimize pulsation dampening and to avoid system vibration damage. This pulsation dampener has two (2) ½" NPT(F) fluid ports designed as a flow-through style so the inlet and discharge ports are interchangeable.

OPERATION: Pulsation dampeners must be precharged with **dry Nitrogen only**.

This pulsation dampener is precharged to 6000 PSI, however, it may be adjusted to offer a more precise control of pulsation in critical applications such as reverse osmosis.

At a temperature of 70° F, optimum pulsation dampener performance is obtained when the precharge is calibrated at 50% of the system operating pressure.

NOTE: When operating at the lower temperatures, precharge should be 15% higher or 65% of system pressure. When operating at higher temperatures, precharge should be 15% lower or 35% of system pressure.

This precharge should be checked every 12 months for normal operation and more frequently for continuous-duty operation.

NOTE: Up to 50 PSI precharge pressure can be lost during the checking of your precharge.

DIMENSIONS

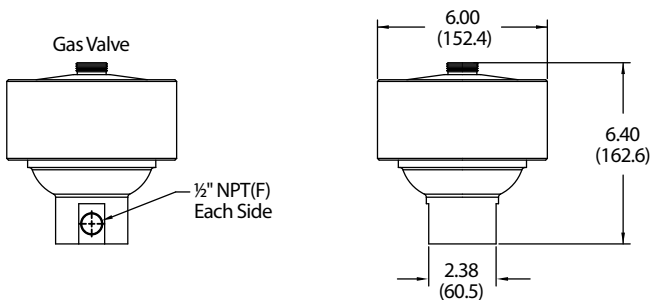

FILLING AND GAUGING INSTRUCTIONS

The following are the steps in both checking the precharge of the pulsation dampener and recharging if there should be a loss of pressure or a need for adjustment.

NOTE: A gas regulator must be mounted between the nitrogen tank and the hose connection from the filling and gauging assembly to enable regulation of the precharge and to prevent excessive pressure from being transmitted directly to the pulsation dampener. Over-pressurization will void the warranty.

1. Before checking your precharge, system pressure should be at zero. Turn the system off.
2. Slightly loosen the sealed valve at the top of the pulsation dampener using a 6 mm, long-handled allen wrench. Thread on and hand tighten the filling and gauging assembly.
3. Be certain the side bleed valve on the gauging assembly is closed.
4. Slowly open the large "T" valve at the top of the gauging assembly until completely open. The gauge on the assembly will read the precharge of the pulsation dampener.
5. Completely back off (close) the valve on the gas regulator, open the nitrogen tank valve and read the nitrogen tank pressure on the first gauge.
6. If the reading on the gauge assembly is 50% of the system pressure, close the top "T" valve and proceed to step 9.
7. If the precharge is too high, keep the top "T" valve open and slowly open the small "T" valve on the side of the gauging assembly to bleed of pressure.
8. If the pressure is less than 50% of the system pressure, slowly open the gas regulator valve until the desired precharge is reached on the second gauge.
9. When the gauge reads the required precharge, close the "T" valve on the top of the gauging assembly to lock the precharge in the pulsation dampener.
10. Back off (close) the gas regulator.
11. Proceed with opening the small side "T" valve on the gauging assembly to relieve (bleed-off) pressure in the assembly and on the second gauge on the gas regulator.
12. Close the side "T" valve on the gauging assembly and remove the assembly from the pulsation dampener.
13. Tighten the pulsation dampener sealed valve and resume operation.

OPTIONAL SPARE PARTS

76501 Charging Screw with NBR Seal Washer

⚠ CAUTIONS AND WARNINGS

All high-pressure systems require a primary pressure regulating device (i.e. regulator, unloader) and a secondary pressure relief device (i.e. pop-off valve, relief valve). Failure to install such relief devices could result in personal injury or damage to pump or property. Cat Pumps does not assume any liability or responsibility for the operation of a customer's high-pressure system. Read all CAUTIONS and WARNINGS before commencing service or operation of any high-pressure system. The CAUTIONS and WARNINGS are included in each Service Manual and with each Accessory Data sheet. CAUTIONS and WARNINGS can also be viewed online at www.catpumps.com/dynamic-literature/cautions-and-warnings or can be requested directly from Cat Pumps.

WARRANTY

View the Limited Warranty online at www.catpumps.com/literature/cat-pumps-limited-warranty