

DATA SHEET

7CP PLUNGER PUMPS



Brass Model: 7CP6160CS

Brass Gearbox Model: 7CP6160CSG1

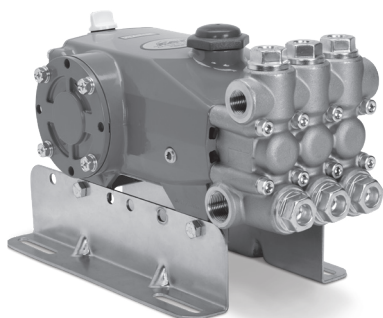

Model 7CP6160CS Shown
(Mounting rails sold separately)

FEATURES

- Triplex plunger design ensures high efficiency and low pulsation.
- Belt-driven option provides precise flow settings.
- Gearbox models available with 1" or 1½" hollow shaft to fit most common engines.
- Direct-drive option offers a compact foot print for electric motors with a NEMA or IEC frame, or SAE hydraulic motors with a bell housing/flexible coupler assembly.
- Pump comes standard with NBR seals. Alternative seal materials are available for higher temperature or chemical compatibility.

COMMON SPECIFICATIONS

	U.S.	Metric
Inlet Pressure Range	Flooded to 70 psi	Flooded to 4.8 bar
Max. Liquid Temp. (NBR)	140° F	60° C
Alternative seals available for higher temperatures up to 180° F		
Bore	0.787"	20 mm
Crankcase Capacity	38 oz	1.15 l
Inlet Ports (2)	¾" NPT(F)	¾" NPT(F)
Discharge Ports (2)	½" NPT(F)	½" NPT(F)
Shaft Diameter	0.945"	24 mm
Weight (7CP6160CS)	30.9 lbs	14.0 kg
Weight (Gearbox Models)	40.4 lbs	18.3 kg
Dimensions	13.46 x 9.25 x 6.89"	342 x 235 x 175 mm

SPECIFICATIONS

7CP6160CS

	U.S. Measure	Metric Measure
Flow	10.6 gpm	40.1 lpm
Pressure Range	100–2500 psi	6.9–172 bar
Pump RPM*	1750 rpm	1750 rpm
Stroke	1.024"	26 mm

7CP6160CSG1

	U.S. Measure	Metric Measure
Flow	10.0 gpm	38.0 lpm
Pressure Range	100–2500 psi	6.9–172 bar
Engine RPM	3400 rpm	3400 rpm
Stroke	1.024"	26 mm

*Pump minimum is 100 RPM.

ALTERNATIVE SEAL CONFIGURATION

MATERIAL	SUFFIX CODE	MAXIMUM TEMPERATURE	
NBR	—	140° F	(60° C)
FPM	.0110	180° F	(82° C)
EPDM	.0220	160° F	(71° C)

See **Tech Bulletin 002** for inlet conditions for high temperature.

DETERMINING THE PUMP RPM	Rated gpm	=	Desired gpm
	Rated rpm	=	Desired rpm
DETERMINING THE REQUIRED HP	hp	=	gpm x psi
	(Electric Brake)	=	1460
DETERMINING MOTOR PULLEY SIZE	Motor Pulley OD	=	Pump Pulley OD
	Pump rpm	=	Motor rpm

Refer to pump **Service Manual** for repair procedure and additional technical information.

PARTS LIST

ITEM	P/N	MATL	DESCRIPTION	QTY
5	126540	STCP R	Screw, HHC Sems (M8 x 20) (See Tech Bulletin 074)	8
8	131405	ALE	Cover, Bearing	1
9	49503	FBR	Shim, Split, 2-Piece, Outer	0-2
10	12393	NBR	O-Ring, Bearing Cover-70D	2
11	49190	NBR	Seal, Oil Crankshaft	1
12	49504	S	Shim, Split, 2-Piece, Inner	0-2
15	63479	STL	Bearing, Roller	2
20	48727	TNM	Rod, Connecting Assembly (See Tech Bulletin 074)	3
25	49649	FCM	Crankshaft, Single-End (M26)	1
30	131407	ALE	Cover, Blind Bearing	1
32	44666	RTP	Cap, Oil Filler	1
33	14177	NBR	O-Ring, Oil Filler Cap-70D	1
36	129343	RBR	Gasket, Flat	1
37	92241	PC	Gauge, Oil, Bubble with Gasket-80D (See Tech Bulletin 074)	1
38	44428	NBR	Gasket, Flat, Oil Gauge-80D	1
39	49948	ABS	Stick, Dip (See Tech Bulletin 130)	1
40	125824	STCP R	Screw, HHC Sems (M6 x 16) (See Tech Bulletin 074)	4
48	25625	STCP	Plug, Drain (1/4" x 19 BSP)	1
49	23170	NBR	O-Ring, Drain Plug-70D	1
50	131403	ALE	Cover, Rear	1
51	14030	NBR	O-Ring, Rear Cover-70D	1
53	131400	ALE	Crankcase	1
64	46969	CM	Pin, Crosshead	3
65	46968	BBNP	Rod, Plunger	3
70	48281	NBR	Seal, Oil Crankcase	3
75	43328	S	Slinger, Barrier	3
90	134938	CC	Plunger, Ceramic (M20 x 53)	3
98	46730	NBR	Washer, Seal-90D	3
99	46729	S	Retainer, Plunger (M6) (See Tech Bulletin 074)	3
100	46964	NY	Retainer, Seal	3
106	43305	NBR	Seal, LPS with S-Spring	3
120	134941	BB	Case, Seal	3
121	13982	NBR	O-Ring, Seal Case-70D	3
127	45191	SNG	V-Packing	6
128	134942	BB	Adapter, Male	3
162	43248	PTFE	Backup Ring, Seat	6
163	43249	NBR	O-Ring, Seat-80D	6
164	49696	S	Seat	6
166	43721	S	Valve	6
167	43251	S	Spring	6
168	44564	PVDF	Retainer, Spring	6
172	17617	NBR	O-Ring, Valve Plug-90D	6
174	43850	BB	Plug, Valve (See Tech Bulletin 074)	6
185	134940	FBB	Head, Manifold	1
188	126513	STCP R	Screw, HSH (M8 x 70) (See Tech Bulletin 074)	8
500	8081	—	Gearbox, 1" Shaft (See Individual Data Sheet)	1
	8072	—	Gearbox, 1½" Shaft (See Individual Data Sheet)	1

R Components comply with RoHS Directive. For additional technical information see www.catpumps.com/literature/tech-bulletins
MATERIAL CODES (Not Part of Part Number): ABS=ABS Plastic ALE=Aluminum Epoxy BB=Brass BBNP=Brass/Nickel Plated CC=Ceramic
CM=Chrome-moly F=Cast Iron FBB=Forged Brass FBR=Fiber FCM=Forged Chrome-moly NBR=Medium Nitrile (Buna-N) NY=Nylon
PC=Poly Carbonate PE=Polyethylene PTFE=Pure Polytetrafluoroethylene PVDF=Polyvinylidene Fluoride RBR=Rubber RTP=Reinforced Composite
S=304SS SNG=Special Blend (Buna) STL=Steel STCP=Steel/Chrome Plated STZP=Steel/Zinc Plated TNM=Special High Strength

EXPLODED VIEW

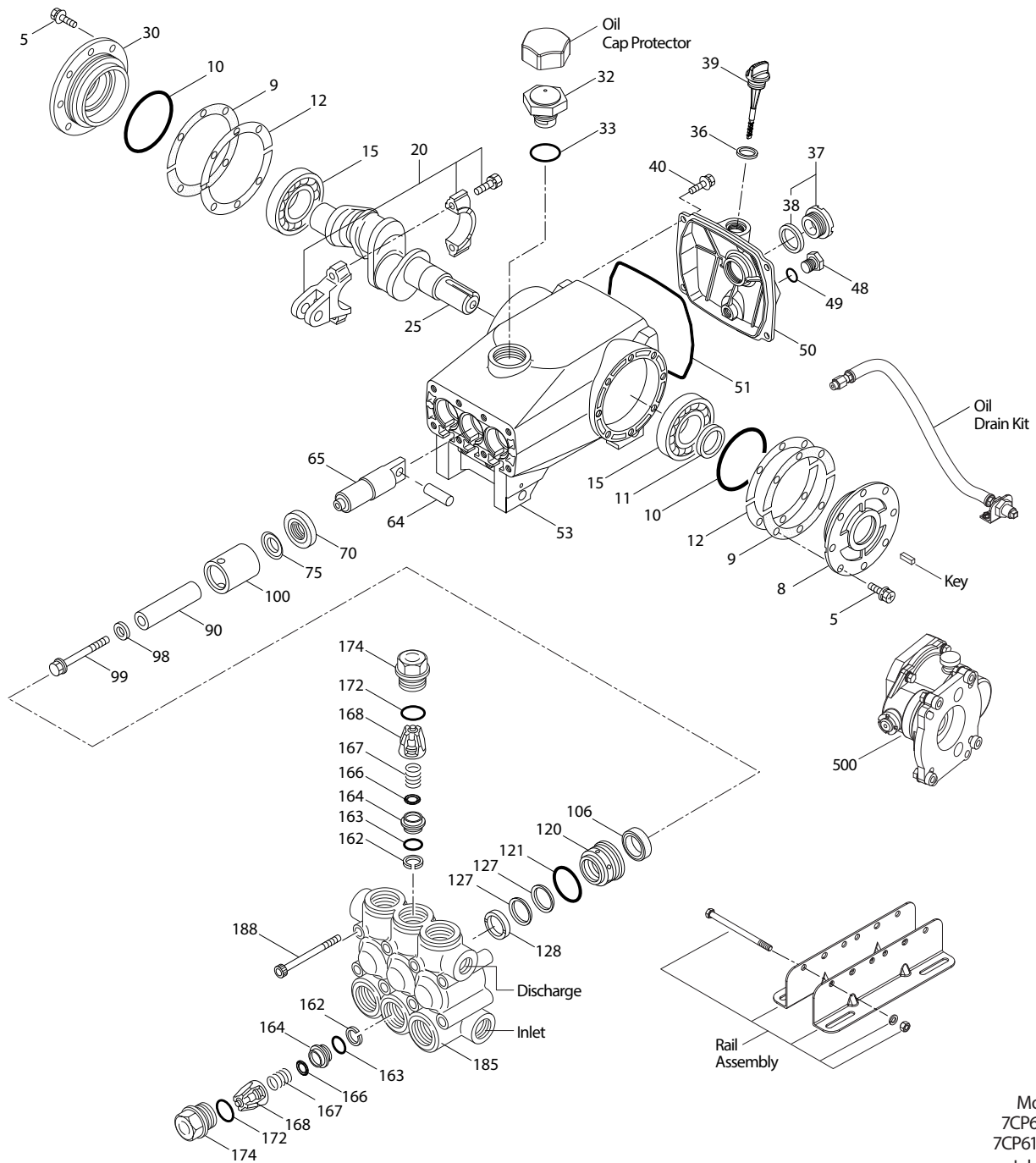

Models
7CP6160CS,
7CP6160CSG1
July 2021

OPTIONAL PARTS AND ACCESSORIES

PART	DESCRIPTION	QTY
30067	Key (M8 x 7.5 x 25)	1
30613	Rail Assembly (5.75" See Dimensional Drawing)	1
76513	Rail Assembly (6.25" See Dimensional Drawing)	1
828710	Protector, Oil Cap	1
34334	Kit, Oil Drain	1
30206	Pulley, 10" 2-Groove "H"	1
33000	Hub, "H" 24mm	1
30696	Pliers, Reverse	1

SERVICE PARTS

PART	DESCRIPTION	QTY
77052	Seal Kit—Standard NBR	1
77053	Valve Kit—Standard NBR	2
6107	Oil, Bottle (21 oz bottle) ISO 68 Hydraulic Fill to Specified Crankcase Capacity Prior to Start-up	2
6124	Lubricant, Anti-Seize (3 oz)	1

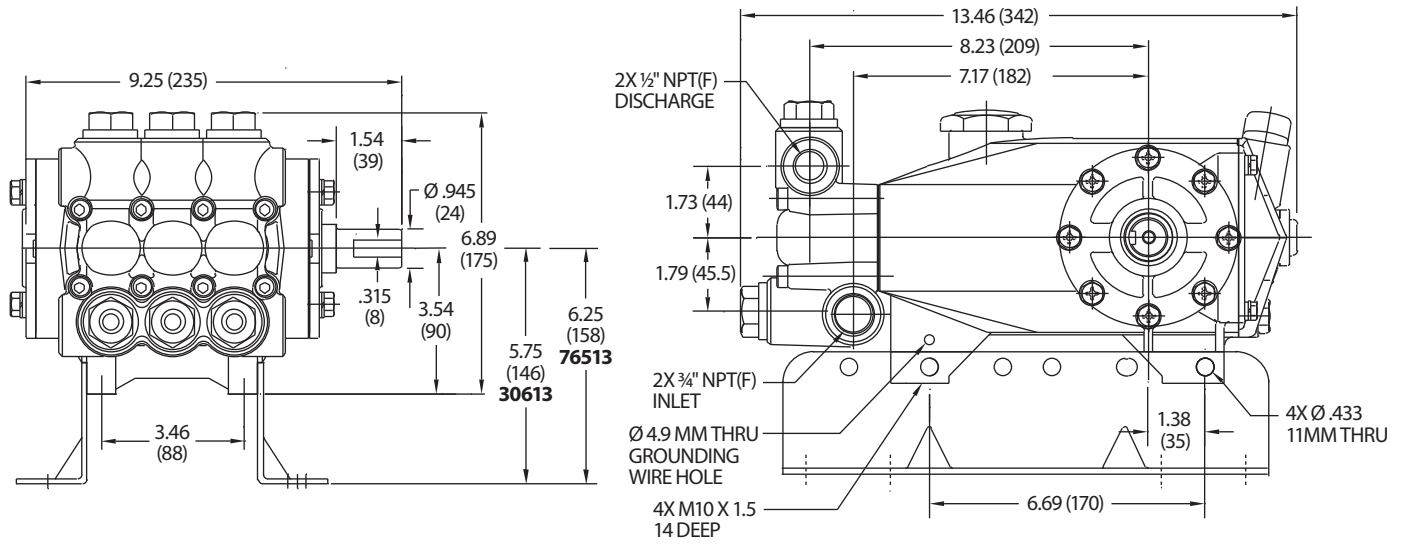

Model 7CP6160CS

SEAL KITS One (1) seal kit required per pump

PUMP MODELS	NBR (STD)
7CP6160CS, 7CP6160CSG1	77052

ITEM (Included in Seal Kits)	DESCRIPTION	QTY
98	46730 Washer, Seal	3
106	43305 Seal, LPS with SS-Spring	3
121	13982 O-Ring, Seal Case	3
127	45191 V-Packing	6

VALVE KITS Two (2) valve kits required per pump

PUMP MODELS	NBR (STD)
7CP6160CS, 7CP6160CSG1	77053

ITEM (Included in Valve Kits)	DESCRIPTION	QTY
162	43248 Backup Ring, Seat	3
163	43249 O-Ring, Valve Seat	3
164	49696 Seat	3
166	43721 Valve	3
167	43251 Spring	3
168	44564 Retainer, Spring	3
172	17617 O-Ring, Valve Plug	3

CAUTIONS AND WARNINGS

All high-pressure systems require a primary pressure regulating device (i.e. regulator, unloader) and a secondary pressure relief device (i.e. pop-off valve, relief valve). Failure to install such relief devices could result in personal injury or damage to pump or property. Cat Pumps does not assume any liability or responsibility for the operation of a customer's high-pressure system. Read all CAUTIONS and WARNINGS before commencing service or operation of any high-pressure system. The CAUTIONS and WARNINGS are included in each Service Manual and with each Accessory Data sheet. CAUTIONS and WARNINGS can also be viewed online at www.catpumps.com/dynamic-literature/cautions-and-warnings or can be requested directly from Cat Pumps.

WARRANTY

View the Limited Warranty online at www.catpumps.com/literature/cat-pumps-limited-warranty