

DATA SHEET

5CP PLUNGER PUMPS



The Pumps with Nine Lives

**Stainless Steel
Models:**

**5CPQ6221, 5CPQ6241CS, 5CPQ6251
5CPQ6271CSS, 5CPQ6281CSS**

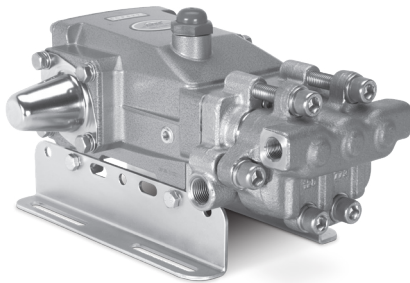

Model 5CPQ6221 Shown
(Rails and shaft protector sold separately)

FEATURES

- Triplex plunger design ensures high efficiency and low pulsation.
- Belt-driven option provides precision flow settings.
- Direct-drive option offers a compact footprint for electric motors with a NEMA or IEC frame, or SAE hydraulic motor with a bell housing/flexible coupler assembly.
- Pump comes standard with NBR seals. Alternative seal materials are available for higher temperature or chemical compatibility.

COMMON SPECIFICATIONS	U.S. MEASURE	METRIC MEASURE
Pump RPM*	1725 rpm	1725 rpm
Inlet Pressure Range	Flooded to 60 psi	Flooded to 4.1 bar
Max. Liquid Temperature (NBR)	160° F	71° C
Alternate seals available for higher temperatures up to 200° F		
Bore	0.787"	20 mm
Crankcase Capacity	17 oz	0.50 l
Inlet Ports (2)	½" NPT(F)	½" NPT(F)
Discharge Ports (2)	¾" NPT(F)	¾" NPT(F)
Shaft Diameter	0.787"	20 mm
Weight	20 lbs	8 kg
Dimensions	11.47 x 10.0 x 5.75"	291.3 x 254 x 146

*Pump minimum is 100 RPM.

SPECIFICATIONS	U.S. MEASURE	METRIC MEASURE
5CPQ6221		
Flow	6.0 gpm	23 lpm
Pressure Range	100–2000 psi	6.9–138 bar
Pump RPM*	1400 rpm	1400 rpm
Inlet Pressure Range	–5–60 psi	–0.35–4.1 bar
Stroke	0.709"	18 mm
5CPQ6241CS		
Flow	4.0 gpm	15 lpm
Pressure Range	100–2000 psi	6.9–138 bar
Stroke	0.394"	10 mm
5CPQ6251		
Flow	5.0 gpm	19 lpm
Pressure Range	100–2000 psi	6.9–138 bar
Stroke	0.472"	12 mm
5CPQ6281CSS		
Flow	5.5 gpm	21 lpm
Pressure Range	100–2000 psi	6.9–138 bar
Stroke	0.557"	14 mm
5CPQ6271CSS		
Flow	6.6 gpm	25 lpm
Pressure Range	100–1800 psi	6.9–124 bar
Stroke	0.650"	16.5 mm
5CPQ6221 Alternate Specifications		
Flow	7.4 gpm	28 lpm
Pressure Range	100–1500 psi	6.9–103 bar
Stroke	0.709"	18 mm

ALTERNATIVE SEAL CONFIGURATION

MATERIAL	SUFFIX CODE	MAXIMUM TEMPERATURE	
NBR	—	160° F	(71° C)
FPM	.0110	180° F	(82° C)
EPDM	.0220	160° F	(71° C)
IPFE	.0770	200° F	(93° C)
HT	.3000	180° F	(82° C)

See **Tech Bulletin 002** for inlet conditions and RPM at high temperature.

DETERMINING THE PUMP RPM	Rated gpm	=	Desired gpm
	Rated rpm	=	Desired rpm
DETERMINING THE REQUIRED HP	hp (Electric Brake)	=	gpm x psi 1460
	DETERMINING MOTOR PULLEY SIZE	Motor Pulley OD Pump rpm	=

Refer to pump **Service Manual** for repair procedure and additional technical information.

PARTS LIST

ITEM	PART #	MATL	DESCRIPTION	QTY
5	119049	SS	Screw, HHC, Sems (M8 x 16) (See Tech Bulletin 074)	8
8	46910	AL	Cover, Bearing (Models 5CPQ6221, 5CPQ6251)	2
	46910	AL	Cover, Bearing (Models 5CPQ6241CS, 5CPQ6271CSS, 5CPQ6281CSS)	1
10	14028	NBR	O-Ring, Bearing Cover-70D (Models 5CPQ6221, 5CPQ6251)	2
11	43222	NBR	Seal, Oil, Crankshaft (Models 5CPQ6221, 5CPQ6251)	2
	43222	NBR	Seal, Oil, Crankshaft (Models 5CPQ6241CS, 5CPQ6271CSS, 5CPQ6281CSS)	1
15	127472	STL	Bearing, Ball	2
20	48742	TNM	Rod Assembly, Connecting (See Tech Bulletin 074)	3
25	46928	FCM	Crankshaft, Dual End (M18) (Model 5CPQ6221)	1
	48203	FCM	Crankshaft, Single End (M10) (Model 5CPQ6241CS)	1
	46982	FCM	Crankshaft, Dual End (M12) (Model 5CPQ6251)	1
	49872	FCM	Crankshaft, Single End (M14) (Model 5CPQ6281CSS)	1
	48368	FCM	Crankshaft, Single End (M16.5) (Model 5CPQ6271CSS)	1
30	48224	AL	Cover, Blind Bearing (Model 5CPQ6241CS)	1
	49776	AL	Cover, Blind Bearing (Models 5CPQ6271CSS, 5CPQ6281CSS)	1
32	46798	—	Cap, Oil Filler	1
33	14179	NBR	O-Ring, Oil Filler Cap-70D	1
37	92241	PC	Gauge, Oil, Bubble with Gasket-80D (See Tech Bulletin 074)	1-2
38	44428	NBR	Gasket, Flat, Oil Gauge-80D	1-2
40	92538	S	Screw, HHC, Sems (M6 x 16) (See Tech Bulletin 074)	4
48	25625	STCP	Plug, Drain (1/4" x 19 BSP)	1
49	23170	NBR	O-Ring, Drain Plug-70D	1
50	46940	AL	Cover, Rear	1
51	14044	NBR	O-Ring, Cover, Rear	1
53	48617	AL	Crankcase	1
64	46746	CM	Pin, Crosshead	3
65	48458	BBNP	Rod, Plunger	3
70	46838	NBR	Seal, Oil, Crankcase	3
71	48208	PVDF	Washer, Oil Seal	3
75	43328	S	Slinger, Barrier	3
88	45697	S	Washer, Keyhole (M18 x 10)	3
90	46841	CC	Plunger (M20 x 50)	3
98	46730	NBR	Washer, Seal-90D	3
99 †	48201	SS	Retainer, Plunger (M6 x 30) (See Tech Bulletin 074)	3
100	46749	PVDF	Retainer, Seal	3
106	44127	NBR	Seal, LPS with SS-Spring	3
110	48552	SS	Manifold, Inlet	1
117	119034	S	Screw, HSH (M8 x 35) (See Tech Bulletin 074)	4
125	833824	SNG	Seal, HPS	3
143	17615	NBR	O-Ring, Inlet Valve Adapter, Rear-75D	3
150	48212	SS	Adapter, Inlet	3
154	43781	NBR	O-Ring, Inlet Valve Adapter, Front-75D	3
155	43781	NBR	O-Ring, Discharge Adapter, Rear-75D	3
157	48211	SS	Adapter, Discharge	3
159	43781	NBR	O-Ring, Discharge Adapter, Front-75D	3
163	43781	NBR	O-Ring, Seat-75D	3
164	48216	SS	Seat	6
165	43793	NBR	O-Ring, Seat-90D	6
166	44038	SS	Valve	6
167	44039	SS	Spring	6
168	44564	PVDF	Retainer, Spring	6
185	48554	SS	Manifold, Discharge	1
186	19085	S	Lockwasher, Split (M12)	6
188	120774	S	Screw, HSH (M12 x 40) (See Tech Bulletin 074)	2
189	89575	S	Screw, HSH (M12 x 60) (See Tech Bulletin 074)	4

Bold print part numbers are unique to a particular pump model.

† Production parts are different than repair parts. For additional technical information see www.catpumps.com/literature/tech-bulletins.

MATERIAL CODES (Not Part of Part Number): AL=Aluminum BBNP=Brass/Nickel Plated CC=Ceramic CM=Chrome-Moly EPDM=Ethylene Propylene Diene Monomer
FCM=Forged Chrome-Moly FPM=Fluorocarbon HT=High Temp IPFE=I-Perfluoroelastomer NBR=Medium Nitrile (Buna-N) PC=Poly Carbonate PVDF=Polyvinylidene Fluoride
S=304SS SS=316SS SNG=Special Blend (Buna) STCP=Steel/Chrome Plated STZP=Steel/Zinc Plated STL=Steel TNM=Special High Strength

EXPLODED VIEW

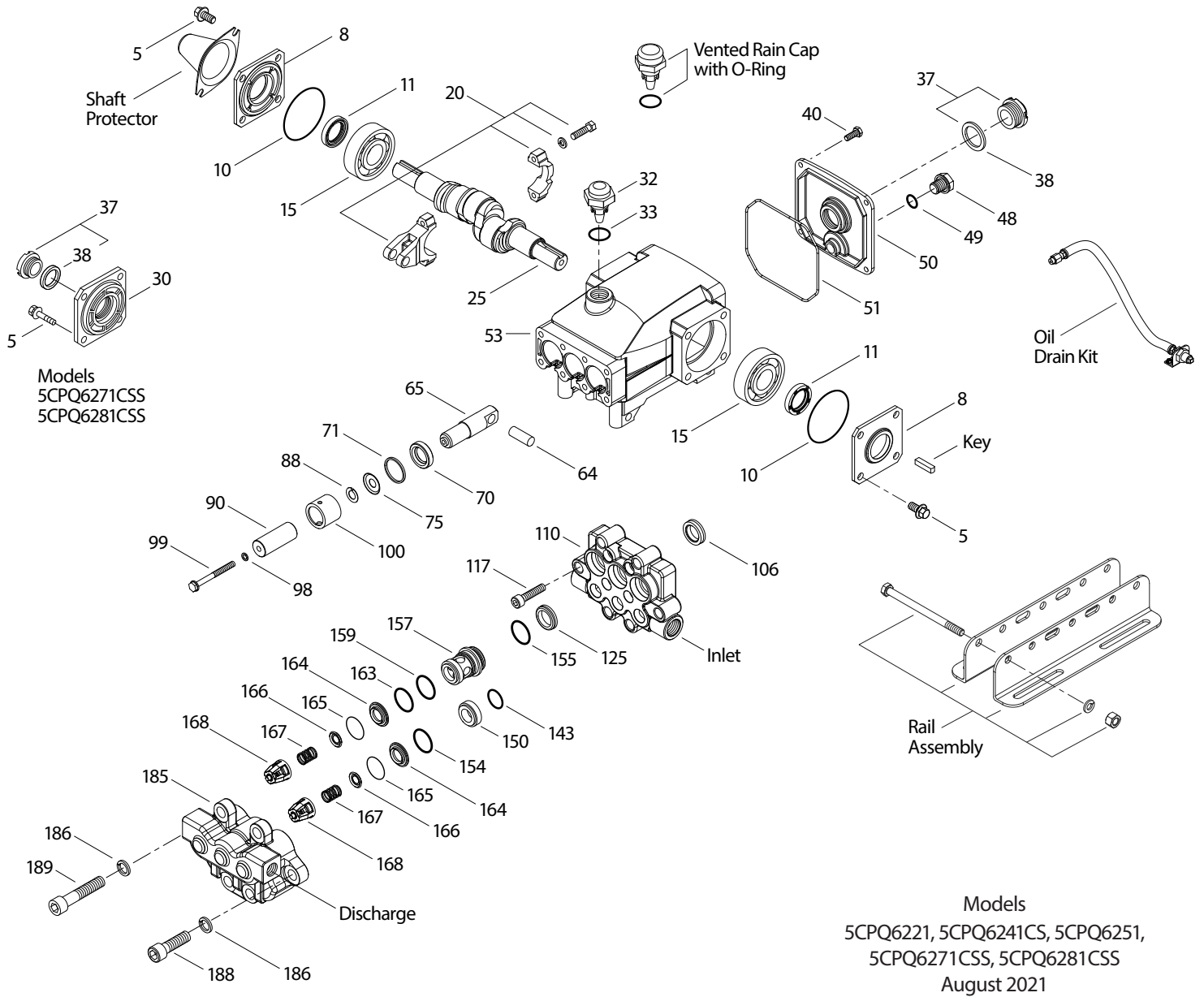

OPTIONAL PARTS AND ACCESSORIES

PART	DESCRIPTION	QTY
30057	Key (M6 x 6 x 25)	1
30611	Assembly, Rail	1
127409	Cap, Vented with O-Ring (Rain Cap)	1
118672	Protector, Shaft (5CPQ6221, 5CPQ6251)	1
34334	Kit, Oil Drain	1
30696	Pliers, Reverse	1

SERVICE PARTS

PART	DESCRIPTION	QTY
76283	Kit, Seal-Standard NBR	1
33972	Kit, Valve-Standard NBR	1
6107	Oil, Bottle (21 oz) ISO 68 Hydraulic (Fill to Specified Crankcase Capacity Prior to Start-up)	1
6124	Gasket, Liquid (3 oz)	1
6139	Lubricant, Antisieze (8 oz)	1

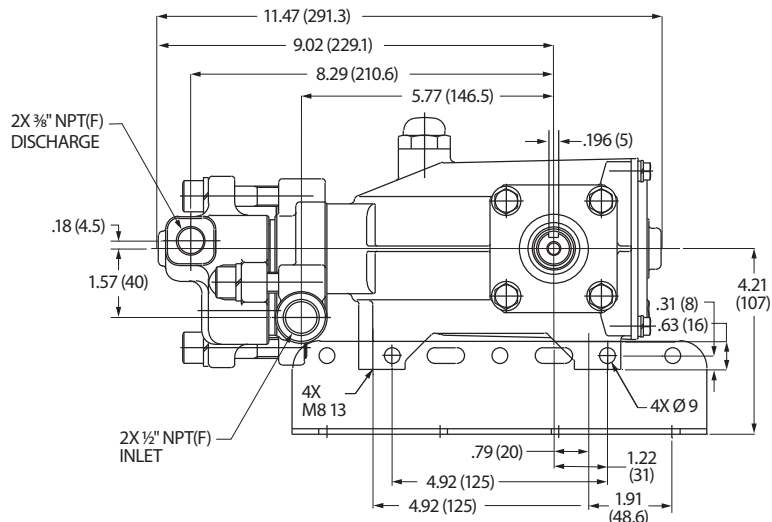
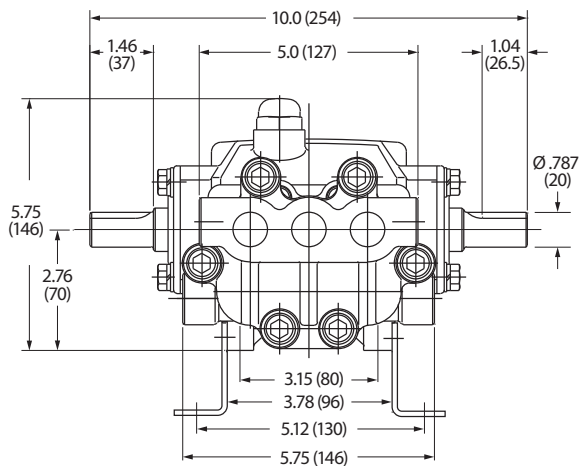

SEAL KITS

One (1) seal kit required per pump

PUMP MODELS	NBR (STD)	FPM (.0110)	EPDM (.0220)◆	IPFE (.0770)	HT (.3000)
5CPQ6221, 5CPQ6241CS, 5CPQ6251, 5CPQ6271CSS, 5CPQ6281CSS	76283	34351	34352	76947*	76677

ITEM (Included in Seal Kits)	DESCRIPTION					QTY	
98	46730	48394	48432	76730	46730	O-Ring, Plunger Retainer	3
106	44127	45153	48429	76149	44127	Seal, LPS with SS-Spring	3
125	833824	44936	46667	46667	46667	Seal, High-Pressure	3
143	17615	15855	48431	701718	17615	O-Ring, Inlet Valve Adapter, Rear	3
154	43781	11337	48430	77338	43781	O-Ring, Inlet Valve Adapter, Front	3
155	43781	11337	48430	77338	43781	O-Ring, Discharge Adapter, Rear	3
159	43781	11337	48430	77338	43781	O-Ring, Discharge Adapter, Front	3

◆ Silicone oil/grease required *Review material codes for individual items (HT generally may be used as alternative)

VALVE KITS

One (1) valve kits required per pump

PUMP MODELS	NBR (STD)	FPM (.0110)	EPDM (.0220)◆	IPFE (.0770)	HT (.3000)
5CPQ6221, 5CPQ6241CS, 5CPQ6251, 5CPQ6271CSS, 5CPQ6281CSS	33972	34362	34363	77332	33972

ITEM (Included in Valve Kits)	DESCRIPTION					QTY	
143	17615	15855	48431	701718	17615	O-Ring, Inlet Valve Adapter, Rear	3
154	43781	11337	48430	77338	43781	O-Ring, Inlet Adapter, Front	3
163	43781	11337	48430	77338	43781	O-Ring, Valve Seat	3
164	48216	48216	48216	48216	48216	Seat	6
165	43793	43791	48490	77359	43793	O-Ring, Valve Seat	6
166	44038	44038	44038	44038	44038	Valve	6
167	44039	44039	44039	44039	44039	Spring	6
168	44564	44564	44564	44564	44564	Retainer, Spring	6

◆ Silicone oil/grease required

⚠ CAUTIONS AND WARNINGS

All high-pressure systems require a primary pressure regulating device (i.e. regulator, unloader) and a secondary pressure relief device (i.e. pop-off valve, relief valve). Failure to install such relief devices could result in personal injury or damage to pump or property. Cat Pumps does not assume any liability or responsibility for the operation of a customer's high-pressure system. Read all CAUTIONS and WARNINGS before commencing service or operation of any high-pressure system. The CAUTIONS and WARNINGS are included in each Service Manual and with each Accessory Data sheet. CAUTIONS and WARNINGS can also be viewed online at www.catpumps.com/dynamic-literature/cautions-and-warnings or can be requested directly from Cat Pumps.

WARRANTY

View the Limited Warranty online at www.catpumps.com/literature/cat-pumps-limited-warranty