

DATA SHEET

DIRECT DRIVE CP GEARBOXES

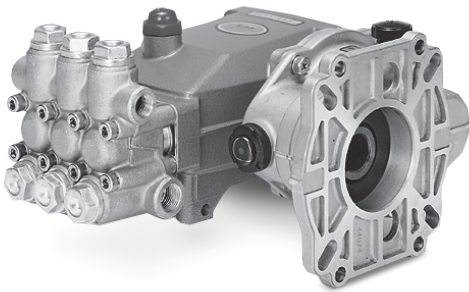

- Models:**
- 8076** *Used on all 5CP models with 1" Gearbox drive*
 - 8077** *Used on all 5CP models with 1½" Gearbox drive*
 - 8081** *Used on all 7CP models with 1" Gearbox drive*
 - 8072** *Used on all 7CP models with 1½" Gearbox drive*



Model 5CP3120G1 with 8076 Gearbox Shown

SPECIFICATIONS	U.S. Measure	Metric Measure
Gear Ratio	2.04 to 1	2.04 to 1
Mounting Face	6½"	165 mm
Engine Shaft Diameter:		
8076, 8081	1"	25.4 mm
8077, 8072	1½"	28.5 mm
Engine Shaft Length	¾"	82.6 mm
Gearbox Capacity	10 oz	0.30 l
Weight:		
8076, 8077	6.38 lbs	2.9 kg
8081, 8072	8.03 lbs	3.6 kg
Dimensions (8076, 8077)	8.19 x 4.53 x 6.42"	208 x 115 x 163 mm
Dimensions (8081, 8072)	8.19 x 5.18 x 6.42"	208 x 132 x 163 mm

GEARBOX FEATURES

- No pulley selection or need for adjustment allows for quick, easy gas engine mounting.
- Compact flange mount permits simple, direct mounting to most gas engines.*
- Totally sealed housing provides independent gearbox lubrication for maximum service life.
- Hardened steel helical designed gears allows for smooth, quiet operation.

* Gas Mounting Flange: SAE J609, Flange B, Extensions 4 (1" Ø) or 4a (1½" Ø)
 Shaft Length = ¾", Pilot Ø = 5/8", B.C. Ø = 6 ½", Thread = 3/8" - 16 UNCTAP

EXPLODED VIEW

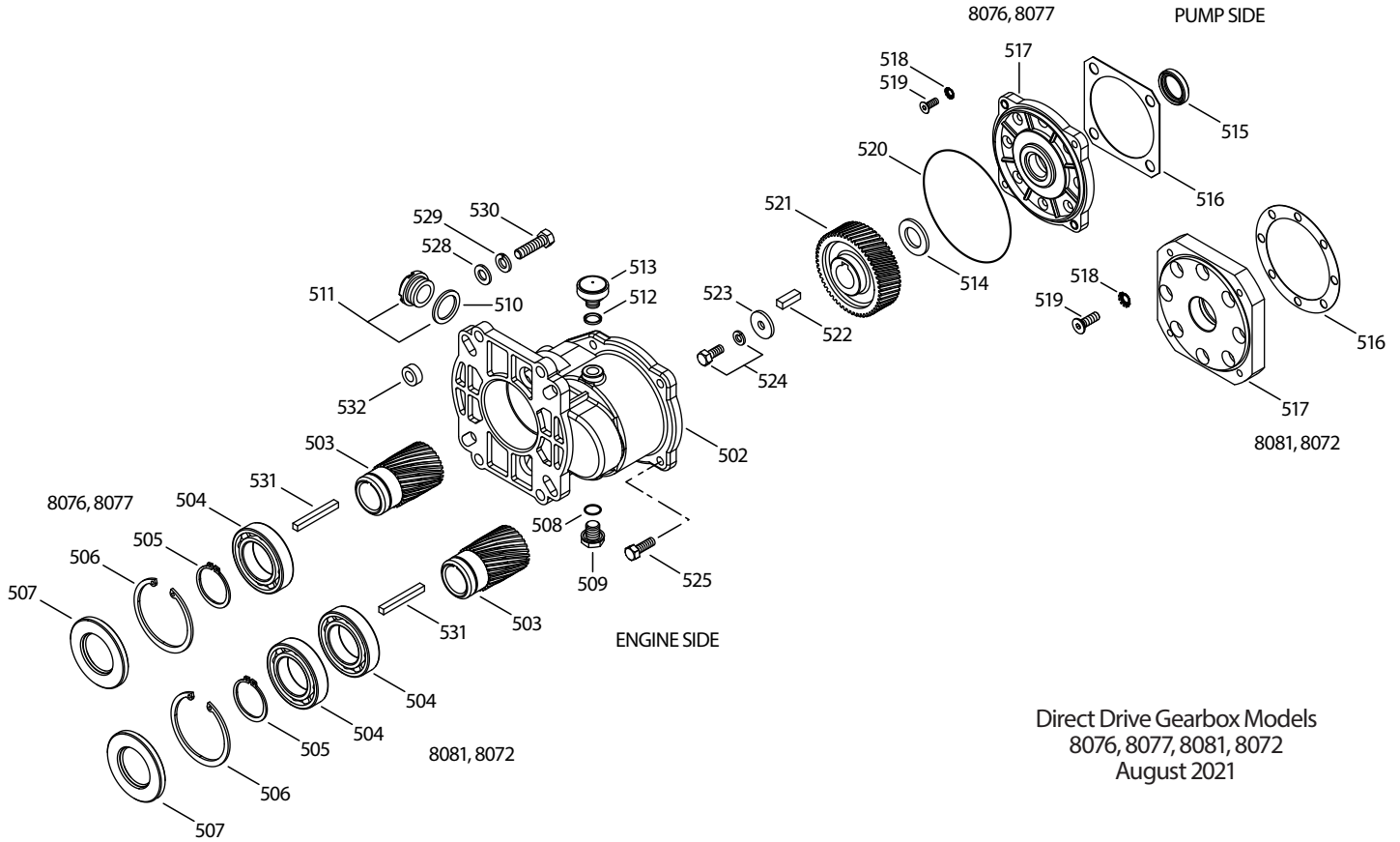

Direct Drive Gearbox Models
8076, 8077, 8081, 8072
August 2021

PARTS LIST

ITEM	PART NUMBER	MATL	DESCRIPTION	GEARBOX MODEL	QTY
502	44673	AL	Housing	8076, 8077	1
	45351	AL	Housing	8081, 8072	1
503	44675	STL	Gear, Pinion 1"	8076	1
	44690	STL	Gear, Pinion 1½"	8077	1
	45352	STL	Gear, Pinion 1"	8081	1
	45358	STL	Gear, Pinion 1½"	8072	1
504	56110	STL	Bearing, Ball	8076, 8077	1
	56110	STL	Bearing, Ball	8081, 8072	2
505	55459	STL	Ring, Retaining (External)	All Models	1
506	146423	STL	Ring, Retaining (Internal)	All Models	1
507	44676	NBR	Seal, Oil, Pinion	All Models	1
508	23170	NBR	O-Ring, Drain Plug-70D	All Models	1
509	25625	STCP	Plug, Oil Drain (¼" x 19 BSP)	All Models	1
510	44428	NBR	Gasket, Flat Flex, Oil Gauge -80D	All Models	1
511	92241	PC	Gauge, Bubble Oil with Gasket	All Models	1
512	103685	NBR	Gasket, Oil Cap	All Models	1
513	44374	—	Cap, Oil Filler	All Models	1
514	126577	STCP R	Washer (M20)	8076, 8077	1
	20129	STZP	Washer (M20)	8076, 8077	1
	31414	STL	Spacer (M24)	8081, 8072	1
515	44679	NBR	Seal, Oil, Bearing Cover	8076, 8077	1

ITEM	PART NUMBER	MATL	DESCRIPTION	GEARBOX MODEL	QTY
	49190	NBR	Seal, Oil, Bearing Cover	8081, 8072	1
516	46914	—	Gasket, Flange	8076, 8077	1
	31383	NBR	Gasket, Flange	8081, 8072	1
517	46913	AL	Flange, Bearing Cover	8076, 8077	1
	76141	AL	Flange, Bearing Cover	8081, 8072	1
518	126746	STCP R	Lockwasher, Conical (M8)	8076, 8077	4
	992879	S	Lockwasher, Conical (M8)	8081, 8072	8
519	46124	STZP	Screw, FH (M8 x 16)	8076, 8077	4
	992877	S	Screw, FH (M8 x 25)	8081, 8072	8
520	14045	NBR	O-Ring, Flange	All Models	1
521	44711	STL	Gear, Helical	8076, 8077	1
	44680	STL	Gear, Helical	8081, 8072	1
522	101814	STL	Key (M6 x 6 x 27)	8076, 8077	1
	44459	STL	Key (M8 x 7 x 24)	8081, 8072	1
523	126579	STZP R	Washer, Flat (M8)	All Models	1
524	126258	STCP R	Screw, Retaining, HHC Sems (M8 x 20)	All Models	1
525	126544	STCP R	Screw, HH Sems (M8 x 25)	All Models	4
528	126574	STZP R	Washer, Flat (M10)	All Models	4
529	126231	STCP R	Lockwasher, (M10)	All Models	4
530	126543	STCP R	Screw, HH (¾-16 x 1¾")	All Models	4
531	44455	STL	Key (¼" x ¼" x 2½")	All Models	1
532	34042	AL	Spacers	All Models	4

R Components comply with RoHS Directive

MATERIAL CODES (Not Part of Part Number): AL=Aluminum NBR=Medium Nitrile (Buna-N) PC=Poly Carbonate S=304SS STL=Steel STCP=Steel/Chrome Plated STZP=Steel/Zinc Plated

Before you begin servicing your pump, **Please carefully read OPERATOR'S MANUAL and separate SERVICE MANUAL** for special lubrication, disassembly and reassembly information.

SERVICING THE GEARBOX

DISASSEMBLY

1. Completely drain lube from gearbox housing.
 2. Remove the four (4) hex head combination (HHC) screws that fasten the gearbox to the engine and separate the gearbox and pump from the engine.
 3. Remove the four (4) HHC screws that fasten the gearbox to the bearing cover flange and separate gearbox housing from the pump.
 4. Place gearbox housing on work surface with seal facing up.
 5. Remove pinion oil seal by inserting a screwdriver between the pinion gear and the inner lip of the seal and pry out.
- NOTE:** Seal will be damaged and must be replaced.
6. Remove the internal retaining ring in the groove below the pinion oil seal using retaining ring pliers. Set aside for re-use.
 7. Remove the pinion gear and bearing. Turn gearbox housing over onto engine mount flange surface. The bearing is pressed into position, so it is necessary to press the pinion gear and bearing out from the rear. Set gearbox housing aside.
 8. Remove bearing from pinion gear. Using reverse pliers, remove the retaining ring from the groove on the pinion gear and press bearing from the pinion. Set aside pinion, bearing and retaining ring.
 9. Remove hex-machined retaining screw, lockwasher and flat holding washer from the center of helical drive gear on the pump shaft.
 10. Slip helical drive gear from the crankshaft.
 11. Remove key from keyway in pump crankshaft. At this point, the gearbox has been disassembled. While the gearbox is in this state of disassembly, it is advisable to examine your pump for any indication of drive end wear. If any of the following conditions are present, removal of the bearing cover flange is necessary. Only trained technicians should service the drive end.

- Leakage between bearing cover flange and pump crankcase.
- Evidence of water in pump crankcase.
- Evidence of water in gearbox crankcase.

NOTE: If removing bearing cover flange is necessary, completely drain oil from the pump crankcase and follow Removing Bearing Cover Flange and Replacing Bearing Cover Flange steps.

REMOVING BEARING COVER FLANGE

1. Remove the HSH screws, lockwashers and washers from the bearing cover flange.
2. Tap flange with a soft mallet to separate from the pump crankcase.
3. Examine pump bearing and replace if worn.
4. Examine oil seal in bearing cover flange and replace if worn.
5. Examine gasket on outside of bearing cover flange and replace if cut or cracked.
6. Examine O-ring on inside outer groove of bearing cover flange and replace if cut or worn. If further pump servicing is needed, refer to your pump service manual and Tech Bulletin 035 on "Servicing Crankcase Section".

REPLACING BEARING COVER FLANGE

1. Press new seal into bearing cover flange.
2. Line up the four holes and mount gasket on outside of bearing cover flange.
3. Line up the inside mounting holes on bearing cover flange with the holes on the pump.
4. Apply Loctite® 242® to the threaded area of screws before replacing. Torque per chart.

REASSEMBLY

1. Slide washer onto pump crankshaft.
 2. Insert key into pump crankshaft keyway until flush with end of shaft.
 3. Examine helical drive gear teeth for wear and replace if necessary. Line up keyway on gear with pump shaft keyway key. Slide onto shaft.
 4. Install flat holding washer, lockwasher and retaining screw, apply Loctite® 242® onto shaft and torque per chart.
 5. Examine gearbox oil gauge and oil drain plug for any evidence of leaking. Replace O-ring and gasket if necessary.
 6. Examine pinion bearing for wear and replace if necessary.
 7. Examine pinion gear teeth for wear and replace if necessary.
 8. Press bearing over pinion gear until seated on shoulder. (Models with dual bearings; press first bearing on until seated then second bearing until seated up to first bearing.)
 9. Install retaining ring on pinion gear and snap into groove.
 10. Insert pinion and gear assembly into gearbox housing and press into position until seated on shoulder.
- NOTE:** Groove for large retaining ring must be visible.
11. Insert the internal retaining ring into pinion bearing housing and snap into the groove.
 12. Lubricate ID and OD of new pinion oil seal. Place oil seal at mouth of pinion bearing housing with garter spring facing down. Carefully press the seal into position until seated on the retaining ring. Keep seal square in position to avoid inner lip hanging up on pinion gear edge.
 13. Rotate pinion gear so that the keyway is up. Mount assembled gearbox housing with helical drive gear onto pump shaft.

NOTE: Carefully match pinion gear teeth and line up mounting holes, then press together.

14. Install the screws to fasten the gearbox to the bearing cover flange and torque per chart.

MOUNTING PUMP WITH GEARBOX ONTO ENGINE

1. Rotate crankshaft of engine until keyway is at the top.
2. Insert key into the keyway and generously apply Loctite® 76764 anti-seize lubricant onto the engine shaft.
3. Line up the keyway of the pinion gear and engine shaft. Carefully slip gearbox onto engine shaft until flush with engine face. Install four (4) hex-machined screws. Torque per chart.

NOTE: Due to varying engine shaft lengths, installation of a small spacer on each of the four (4) hex-machined screws between the gearbox flange and engine face may be necessary.

4. Before starting operation, fill gearbox housing to oil gauge dot with Cat Pumps gear lube PN 6110 or an 80W-140 gear lube. Fill crankcase of the pump to oil gauge dot with Cat Pumps special premium grade hydraulic oil PN 6107.

FIELD CONVERSION FROM STANDARD PUMP

To convert from a standard pump to a gearbox pump, remove four (4) HHC combination head screws the existing bearing cover and gasket. Replace with new gasket, gearbox bearing cover flange and four (4) lockwashers and new hex socket flat head screws.

The bearing for the 7CP series pumps is a tapered roller bearing with an outer race. Remove the standard bearing cover from the pump. Remove outer race from the bearing cover by gently pounding it on a work surface to unseat it. Then use a bearing puller tool to pull race from the bearing cover. Next, press outer race into gearbox bearing cover flange. Be certain race is completely seated in flange before mounting onto the pump.

TORQUE CHART

Description	Thread	Tool	Torque
Gearbox Housing to Bearing Cover Flange	M8	13 mm	70 in-lbs (8 Nm)
Bearing Cover Flange to Pump (M8)	M8	5 mm	125 in-lbs (14.1 Nm)
Drive Gear Retaining Screw	M8	13 mm	110 in-lbs (12.3 Nm)
Engine Mounting Screw	3/8-16	3/16"	110 in-lbs (12.3 Nm)

DIMENSIONAL

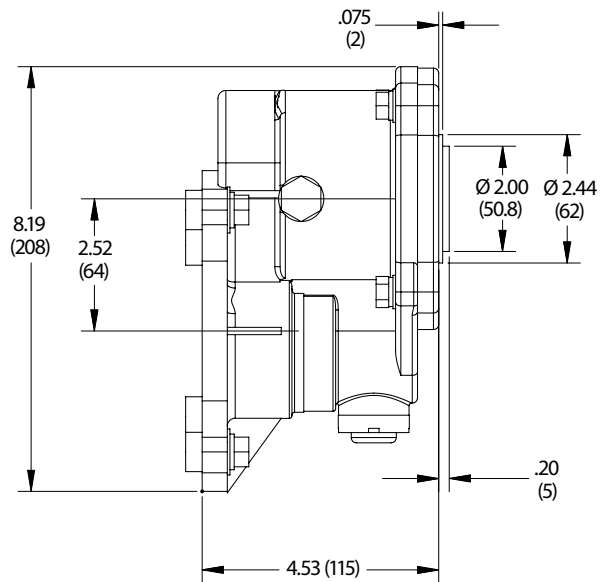
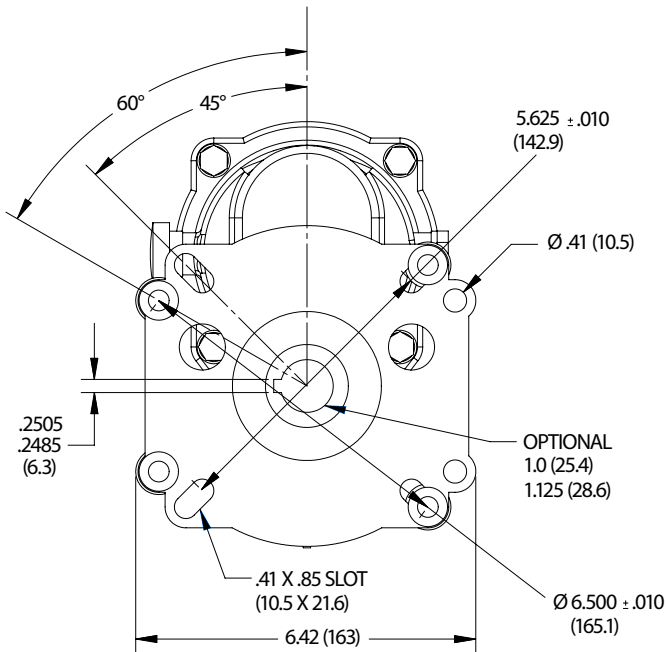

⚠ CAUTIONS AND WARNINGS

All high-pressure systems require a primary pressure regulating device (i.e. regulator, unloader) and a secondary pressure relief device (i.e. pop-off valve, relief valve). Failure to install such relief devices could result in personal injury or damage to pump or property. Cat Pumps does not assume any liability or responsibility for the operation of a customer's high-pressure system. Read all CAUTIONS and WARNINGS before commencing service or operation of any high-pressure system. The CAUTIONS and WARNINGS are included in each Service Manual and with each Accessory Data sheet. CAUTIONS and WARNINGS can also be viewed online at www.catpumps.com/dynamic-literature/cautions-and-warnings or can be requested directly from Cat Pumps.

WARRANTY

View the Limited Warranty online at www.catpumps.com/literature/cat-pumps-limited-warranty