

Gas engine or electric motor must be purchased separately.

## FEATURES

- Triplex plunger design provides a smooth liquid flow.
- Specially formulated V-Packings and concentric, polished ceramic plungers assure maximum seal life.
- Compact, hollow shafted pump for direct mounting to either 1" gas or 3/4" electric shaft. Eliminates the need for pulleys, belts or gearboxes.
- Integral regulating unloader with built-in by-pass standard on all units to assure system pressure control and pump protection.
- Stacked valve design for ease in servicing.
- Fixed chemical injector for cleaning flexibility.

### ⚠ CAUTIONS AND WARNINGS

All High Pressure Systems require a primary pressure regulating device (i.e. regulator, unloader) and a secondary pressure relief device (i.e. pop-off valve, relief valve). Failure to install such relief devices could result in personal injury or damage to pump or property. CAT PUMPS does not assume any liability or responsibility for the operation of a customer's high pressure system.

Read all CAUTIONS and WARNINGS before commencing service or operation of any high pressure system. The CAUTIONS and WARNINGS are included in each service manual and with each Accessory Data sheet. CAUTIONS and WARNINGS can also be viewed online at [www.catpumps.com/cautions-warnings](http://www.catpumps.com/cautions-warnings) or can be requested directly from CAT PUMPS.

### WARRANTY

View the Limited Warranty on-line at [www.catpumps.com/warranty](http://www.catpumps.com/warranty).

## Direct-Drive Plunger Pumps

**Gas Model**                    **3SPX30G1I**  
**Electric Model**            **3SPX35GEI**

### SPECIFICATIONS

	U.S. Measure	Metric Measure
<b>MODEL 3SPX30G1I</b>		
Flow .....	3.0 gpm	(11.4 lpm)
Pressure Range.....	100 to 3000 psi	(7 to 210 bar)
Stroke.....	0.315"	(8.0 mm)
Max. RPM.....	3450 rpm	(3450 rpm)
Shaft Diameter (Hollow - Gas) .....	1"	(25.4 mm)

### MODEL 3SPX35GEI

Flow .....	3.5 gpm	(13.2 lpm)
Pressure Range.....	100 to 2500 psi	(7 to 175 bar)
Stroke.....	0.346"	(8.8 mm)
Max. RPM.....	3450 rpm	(3450 rpm)
Shaft Diameter (Hollow - Elec.) .....	3/4"	(19 mm)

### COMMON PUMP SPECIFICATIONS

Inlet Pressure Range.....	Flooded to 60 psi	(Flooded to 4 bar)
Bore .....	0.551"	(14 mm)
Max. Liquid Temperature.....	140°F	(60°C)
Crankcase Capacity.....	10.15 oz.	(0.30 l)
Inlet Port (1).....	3/8" NPTF	(3/8" NPTF)
Accessory Inlet Port (1) .....	1/4" NPTF	(1/4" NPTF)
Accessory/Discharge Port (1).....	3/8" NPTF	(3/8" NPTF)
Discharge Port (1).....	3/8" NPTM	(3/8" NPTM)
Weight .....	13.9 lbs.	(6.3 kg)
Dimensions (Pump Only) .....	5.28 x 7.80 x 8.03"	(134 x 198 x 204 mm)

### ELECTRIC HORSEPOWER REQUIREMENTS

MODELS	FLOW		PRESSURE			RPM
	U.S. gpm	lpm	psi 2000 bar 140	psi 2500 bar 175	psi 3000 bar 210	
<b>3SPX30G1I</b>	3.0	11.4	4.1	5.1	6.2	3450
<b>3SPX35GEI</b>	3.5	13.2	4.8	6.0	N/A	3450

<b>DETERMINING THE PUMP R.P.M.</b>	Rated G.P.M.	=	"Desired" G.P.M.
	Rated R.P.M.	=	"Desired" R.P.M.
<b>DETERMINING THE REQUIRED H.P.</b>	GPM x PSI 1460	=	Electric Brake H. P. Required
<b>DETERMINING MOTOR PULLEY SIZE</b>	Motor Pulley O.D. Pump R.P.M.	=	Pump Pulley O.D. Motor R.P.M.

See complete Drive Packages [Incls: Pulleys, Belts, Hubs, Key] Tech Bulletin 003. Refer to pump **Service Manual** for repair procedure and additional technical information.

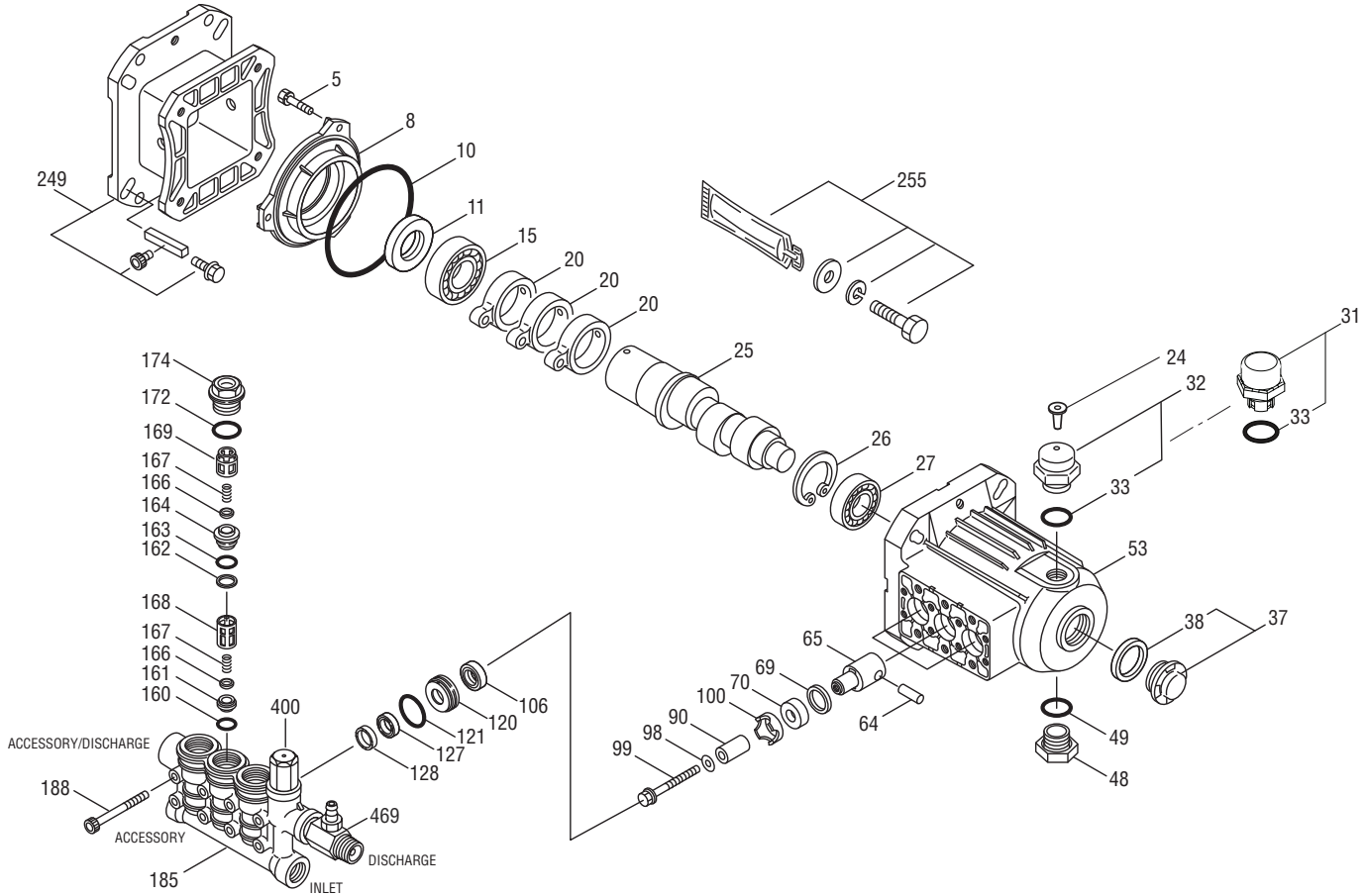

**PARTS LIST**

ITEM	P/N	MATL	DESCRIPTION	QTY	ITEM	P/N	MATL	DESCRIPTION	QTY
5	549360	STCP R	Screw, HHC Sems (M6x14)	3	120	49374	BB	Case, Seal	3
8	547084	AL	Cover, Bearing	1	121	13977	NBR	O-Ring, Seal Case - 70D	3
10	14041	NBR	O-Ring, Bearing Cover - 70D	1	127	547082	SNG	V-Packing	3
11	125351	NBR	Seal, Oil	1	128	547083	PVDF	Adapter, Male	3
15	56110	STL	Bearing, Ball, Inner	1	160	17428	NBR	O-Ring, Inlet Seat - 80D	3
20	547020	TNM	Rod, Connecting Assy	3	161	547077	S	Seat, Inlet	3
24	549608	LDPE	Plug, Oil Cap	1	162	48361	D	Back-up-Ring, Discharge Seat	3
25	<b>548823 FCM</b>		Crankshaft, 3450 RPM, 1", 8.0 mm	1	163	43358	NBR	O-Ring, Discharge Seat - 70D	3
	<b>547148 FCM</b>		Crankshaft, 3450 RPM, 3/4", 8.8 mm	1	164	547076	S	Seat, Discharge	3
26	12385	STL	Ring, Retaining	1	166	547098	S	Valve	6
27	15710	STL	Bearing, Ball, Outer	1	167	46865	S	Spring	6
31	549726	—	Cap, Vented w/O-Ring	1	168	543988	PVDF	Retainer, Spring, Inlet	3
32	547961	RTP	Cap, Oil Filler w/O-Ring	1	169	547441	PVDF	Retainer, Spring, Discharge	3
33	14179	NBR	O-Ring, Oil Filler Cap - 70D	1	172	142807	NBR	O-Ring, Valve Plug - 90D	3
37	92241	—	Gauge, Oil, Bubble w/Gasket - 80D	1	174	547104	BB	Plug, Valve	3
38	44428	NBR	Gasket, Flat, Oil Gauge - 80D	1	185	548870	FBB	Head, Manifold w/Integral Unloader Body	1
48	44842	NY	Plug, Drain	1	188	542406	STZP	Screw, HSH (M6x60)	8
49	14179	NBR	O-Ring, Drain Plug - 70D	1		549357	STCP R	Screw, HSH (M6x60)	8
53	547111	AL	Crankcase	1	249	31643	—	Mount, Adapter Assy, Gas	1
64	16948	CM	Pin, Crosshead	3		31657	—	Mount, Adapter Assy, Electric	1
65	548872	BB	Rod, Plunger	3	255	30514	STZP	Mount, Bolt Assy, Electric/Gas	1
69	126259	STCP R	Washer, Oil Seal	3	283	990394	—	Kit, Oil Drain (Not Shown)	1
70	25301	NBR	Seal, Oil - 80D	3	299	549465	FBB	Head, Complete (Incls: 106-188)	1
90	547091	CC	Plunger (M14x25.5)	3	300	31674	NBR	Kit, Seal (Incls: 98,106,121,127,128)	1
98	46730	NBR	Washer, Seal - 90D	3	310	31647	NBR	Kit, Valve	1
99	542405	S	Retainer, Plunger (M6x35)	3				(Incls: 160,161,162,163,164,166,167,168,169,172)	
100	44869	PVDF	Retainer, Seal	3	400	—	—	Unloader, Integral (See Individual Parts)	1
106	45188	NBR	Seal, LPS w/S-SPG	3	469	7332	—	Injector, Chemical Fixed	1

*Italics are optional items.* [ ] Date of latest production change. R Components comply with RoHS Directive.

R Components comply with RoHS Directive. See Tech Bulletins 002, 024, 036, 043, 055, 074, 083 and 092 for additional information.

MATERIAL CODES (Not Part of Part Number): AL=Aluminum BB=Brass CC=Ceramic CM=Chrome-Moly D=Acetal FBB=Forged Brass FCM=Forged Chrome-Moly

LDPE=Low Density Polyethylene NBR=Medium Nitrile (Buna-N) NY=Nylon PVDF=Polyvinylidene Fluoride RTP=Reinforced Composite

S=304SS SNG=Special Blend (Buna) STCP=Steel/Chrome Plated STL=Steel STZP=Steel/Zinc Plated TNM=Special High Strength

NOTE: Discard Key which may come standard with most motors and engines and **use only the key included in this kit.**

# INTEGRAL UNLOADER

Specifications	U.S. Measure	Metric Measure
Flow .....	3.5 gpm	(13.2 lpm)
PSI Range.....	100-3000 psi	(7-210 bar)
Discharge Port.....	M18 x 1.0	(M18 x 1.0)

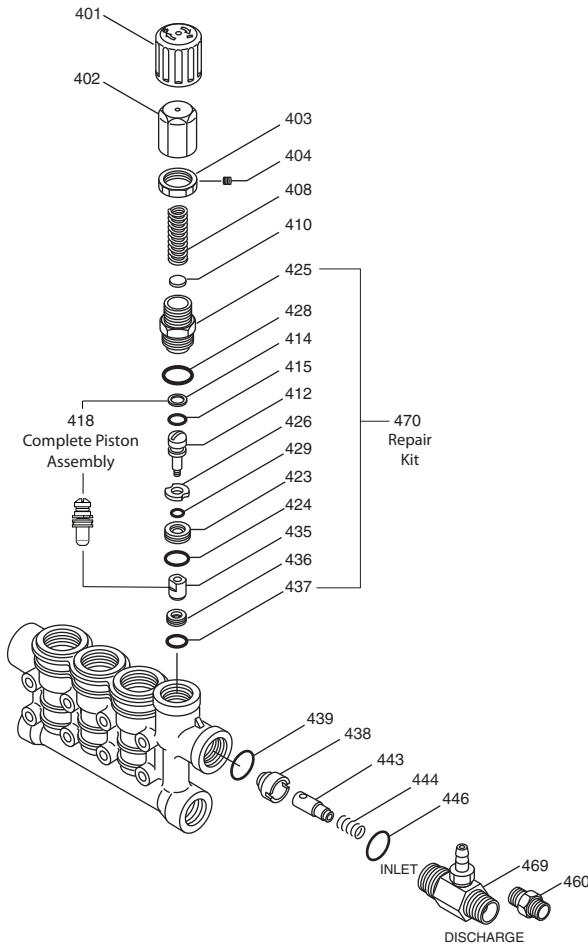

## PARTS LIST

ITEM P/N	MATL	DESCRIPTION	QTY
401	547797	NY Handle, Adjusting	1
402	547798	BB Cap, Adjusting	1
403	548671	BB Nut, Lock (M18x1)	1
404	548675	STL Screw, Set (M4x1)	1
408	32094	STZP R Spring, Pressure	1
410	549352	STCP R Retainer, Spring	1
412	45694	S Stem, Piston (M5)	1
414	20184	PTFE Back-up-Ring, Piston Stem	1
415	14190	NBR O-Ring, Piston Stem - 70D	1
418	—	BB Assy, Piston (Included In Repair Kit)	1
423	46249	BB Retainer, Valve	1
424	13966	NBR O-Ring, Valve Retainer (Outer) - 70D	1
425	547799	BB Retainer, Piston	1
426	46250	S Washer	1
428	26133	NBR O-Ring, Piston Retainer - 80D	1
429	17399	NBR O-Ring, Valve Retainer (Inner) - 80D	1
435	547800	S Valve/Ball Assembly	1
436	49664	S Seat	1
437	13963	NBR O-Ring, Seat - 70D	1
438	46254	NY Seat, Check Valve	1
439	13963	NBR O-Ring Check Valve Seat - 70D	1
443	547826	BB Valve, Check w/NBR O-Ring	1
444	45924	S Spring, Check Valve	1
446	26133	NBR O-Ring, Body - 80D	1
460	107681	BB Fitting, Discharge (3/8" NPTF x M18)	1
468	31767	NBR Kit, O-Ring (Incls: 414, 415, 424, 428, 429, 437, 439, 446)	1
469	7332	BB Injector, Fixed Chemical	1
470	31465	NBR Kit, Repair (Incls: 412, 414, 415, 423, 424, 425, 426, 428, 429, 435, 436, 437)	1

*Italics are optional items.* R Components comply with RoHS Directive.  
 MATERIAL CODES (Not Part of Part Number): BB=Brass NBR=Medium Nitrile (Buna-N) NY=Nylon PTFE=Pure Polytetrafluoroethylene S=304SS STL=Steel STCP=Steel/Chrome Plated STZP=Steel/Zinc Plated

# 7332 FIXED CHEMICAL INJECTOR

SPECIFICATIONS	U.S. Measure	Metric Measure
Flow .....	3.5 gpm	(13.2 lpm)
Nozzle Orifice.....	2.1 mm	(2.1 mm)
Hose Barb .....	1/4"	(1/4")
Tapped Barb .....	8/32" UNF	(8/32" UNF)
Inlet Port.....	M18x1.0	(M18x1.0)
Discharge Port .....	3/8" NPTM	(3/8" NPTM)
Weight.....	5.3 oz.	(0.15 kg)
Dimensions.....	2 x 1 x 1.75"	(52 x 25 x 45 mm)

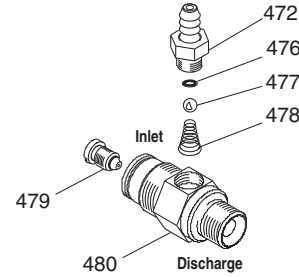

## PARTS LIST

ITEM P/N	MATL	DESCRIPTION	QTY
472	—	BB Barb	1
476	14187	NBR O-Ring, Barb - 70D	1
477	46259	S Ball	1
478	46260	S Spring	1
479	—	BB Orifice	1
480	—	BB Body	1

R Components comply with RoHS Directive.  
 MATERIAL CODES (Not Part of Part Number):  
 BB=Brass NBR=Medium Nitrile (Buna-N) S=304SS

## CHEMICAL INJECTOR PERFORMANCE CHART

Desired Pump Flow	Orifice Size	Injector Model	Maximum Injecting Pressure	Maximum Chemical Draw	Pressure Drop Across Injector At System Pressure (3000 PSI)
3.0	2.1 mm	7332	163 psi	35.5 oz/min	200 psi
3.5	2.1 mm	7332	200 psi	45.6 oz/min	258 psi

Optimum performance of chemical injector occurs with a 35 ft. high pressure hose and a minimum 3/8" I.D. The type of hose, extended lengths, reduced I.D. and fittings may create back pressures in excess of the low pressure nozzle rating and prevent the injector from drawing chemical. See Hose Friction Loss Chart in Service Manual.

**Deduct hose friction loss from above low PSI Nozzle. Contact Cat Pumps for assistance with other options.**

**CAUTION:** Deduct the pressure drop shown in the performance chart from your desired system pressure to arrive at the maximum high pressure nozzle rating. This is essential to avoid over-pressurizing the pump.

## UNLOADER TYPE

An integral unloader with built-in by-pass is part of the discharge manifold to provide system pressure regulation and pump protection. This pump also includes a fixed chemical injector for chemical application.

## OPERATION:

Pump should be purged of air before commencing with operation. Liquid must flow through the pump only to assure full system pressure is reached.

Install a pressure gauge close to the manifold head of the pump to assist in setting system pressure and to periodically monitor system pressure.

Setting and adjusting the unloader pressure must be done with the system turned on. Start the system with the unloader backed off to the lowest pressure setting (counterclockwise direction). Squeeze the trigger and read the pressure on the gauge at the pump. Do not read pressure at the gun or nozzle. If more pressure is desired, release the trigger, turn adjusting cap one quarter turn in a clockwise direction. Squeeze the trigger and read the pressure. Repeat this process until the desired system pressure is reached. Thread locking nut up to adjusting cap and tighten set screw.

**NOTE:** Pressure is not set at the factory.

## SERVICE:

The unloader should be serviced on the same schedule as the seals in the pump. Refer to 3SPX Service Manual for start-up, servicing of seals and valves, torque requirements and diagnosis and maintenance chart.

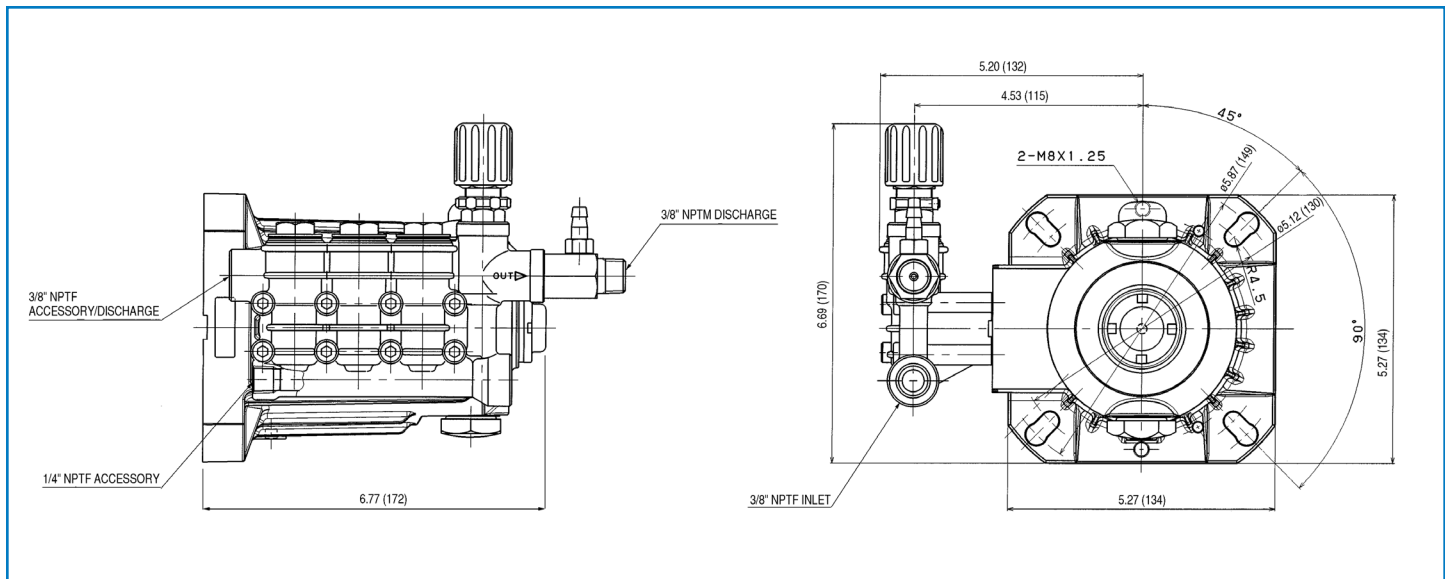

Model 3SPX30G11, 3SPX35GEI

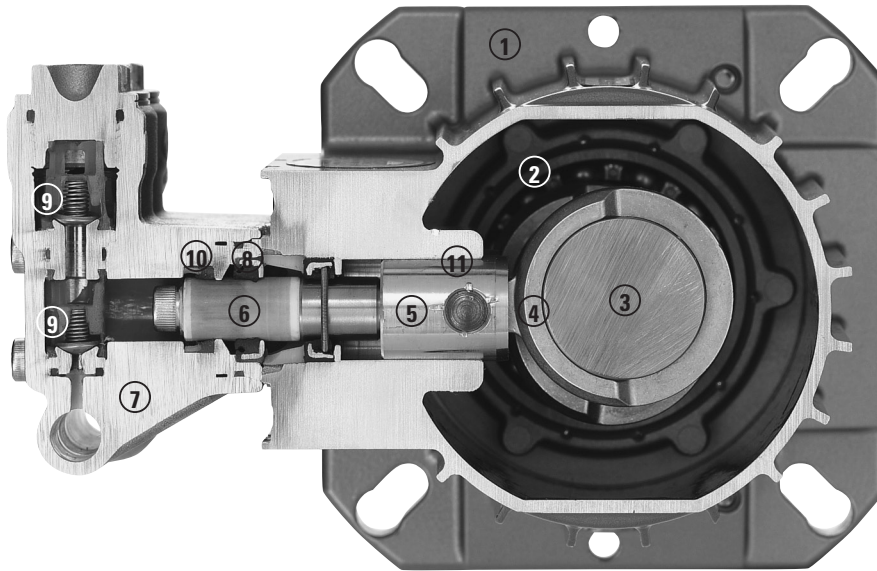

- 1 Die cast flange-style aluminum **crankcase** provides high strength, lightweight, and excellent tolerance control.
- 2 Heavy-duty dual crankshaft **bearings** provide extended drive-end life.
- 3 Chrome-moly **crankshaft** provides unmatched strength and surface hardness for long life.
- 4 High strength **connecting rods** assure durability and bearing quality.
- 5 Stainless steel **plunger rods** with chrome-moly crosshead pins for strength and wear resistance.
- 6 Special concentric, high-density, polished, solid ceramic **plungers** provide a true wear surface and extended seal life.
- 7 High tensile strength, forged brass **manifold head** with built-in integral unloader and eight mounting screws for exceptional strength.
- 8 100% wet **seal** design adds to service life by allowing pumped liquids to cool and lubricate on both sides.
- 9 Stacked **valve assemblies** include stainless steel valves, seats and springs to provide corrosion-resistance, ultimate seating and extended life.
- 10 Unique design and specially formulated **V-Packings** offer unmatched performance and seal life.
- 11 **Crossheads** are 360° supported for uncompromising alignment.



**CAT PUMPS**  
 1681 - 94TH LANE N.E. MINNEAPOLIS, MN 55449-4324  
 PHONE (763) 780-5440 — FAX (763) 780-2958  
 e-mail: techsupport@catpumps.com  
 www.catpumps.com