

Gas engine must be purchased separately.

Direct-Drive Plunger Pumps

Models

**5DX30G1, 5DX35G1
5DX40G1, 5DX50G1**

FEATURES

- Triplex plunger design provides a smooth liquid flow.
- Specially formulated Hi-Pressure V-Packings and concentric, polished ceramic plungers assure maximum seal life.
- Built-in flange mount for easy, direct mounting to most gas engines. Eliminates the need for pulleys, belts, gearboxes.
- Modular Regulating Unloader with built-in by-pass and flow-thru screws is standard to assure system pressure control and pump protection.
- Optional direct mounting fixed or adjustable Chemical Injector for cleaning flexibility.

SPECIFICATIONS

	U.S. Measure	Metric Measure
MODEL 5DX30G1		
Flow	3.0 GPM	(11.4 L/M)
Pressure Range	100 to 3200 PSI	(7 to 220 BAR)
Stroke	0.252"	(6.4 mm)
MODEL 5DX35G1		
Flow	3.5 GPM	(13.2 L/M)
Pressure Range	100 to 3200 PSI	(7 to 220 BAR)
Stroke	0.311"	(7.9 mm)
MODEL 5DX40G1		
Flow	4.0 GPM	(15.0 L/M)
Pressure Range	100 to 3200 PSI	(7 to 220 BAR)
Stroke	0.354"	(9.0 mm)
MODEL 5DX50G1		
Flow	5.0 GPM	(19.0 L/M)
Pressure Range	100 to 2500 PSI	(175 BAR)
Stroke	0.441"	(11.2 mm)

COMMON PUMP SPECIFICATIONS

Max. RPM	3200 RPM	(3200 RPM)
Engine Mounting Face	6.5"	(6.5")
Inlet Pressure Range	Flooded to 75 PSI	(Flooded to 5.25 BAR)
Bore	0.630"	(16 mm)
Shaft Diameter (Hollow)	1"	(25.4 mm)
Max. Liquid Temperature	140°F	(62°C)
Crankcase Capacity	22.65 oz.	(0.67 L)
Inlet Ports (2)	1/2" NPTF	(1/2" NPTF)
Discharge Ports (2)	3/8" NPTF	(3/8" NPTF)
Weight (Pump Only)	24.55 lbs.	(11.1 kg)
Dimensions (Pump Only)	10.83 x 7.08 x 6.38"	(275 x 180 x 162 mm)

HORSEPOWER REQUIREMENTS

MODEL	FLOW		PRESSURE			RPM
	U.S. GPM	L/M	PSI	PSI	PSI	
			2000	2500	3200	
		BAR	BAR	BAR		
5DX30G1	3.0	11.4	4.2	5.2	6.6	3200
5DX35G1	3.5	13.2	4.8	6.0	7.7	3200
5DX40G1	4.0	15.0	5.5	6.9	8.8	3200
5DX50G1	5.0	19.0	6.9	8.6	N/A	3200

DETERMINING THE PUMP R.P.M.	$\frac{\text{Rated G.P.M.}}{\text{Rated R.P.M.}}$	=	$\frac{\text{"Desired" G.P.M.}}{\text{"Desired" R.P.M.}}$
DETERMINING THE REQUIRED H.P.	$\frac{\text{GPM x PSI}}{1460}$	=	Electric Brake H.P. Required
DETERMINING MOTOR PULLEY SIZE	$\frac{\text{Motor Pulley O.D.}}{\text{Pump R.P.M.}}$	=	$\frac{\text{Pump Pulley O.D.}}{\text{Motor R.P.M.}}$

Note: Consult engine manufacturer when using gas or diesel engine. Refer to pump Service Manual for important Inlet Condition Check-List, Start-up Procedure, Tech Bulletins and Pump Maintenance information.

"Customer confidence is our greatest asset"

EXPLODED VIEW

February 2001

5DX PLUNGER PUMP MODELS

5DX30G1, 5DX35G1, 5DX40G1, 5DX50G1

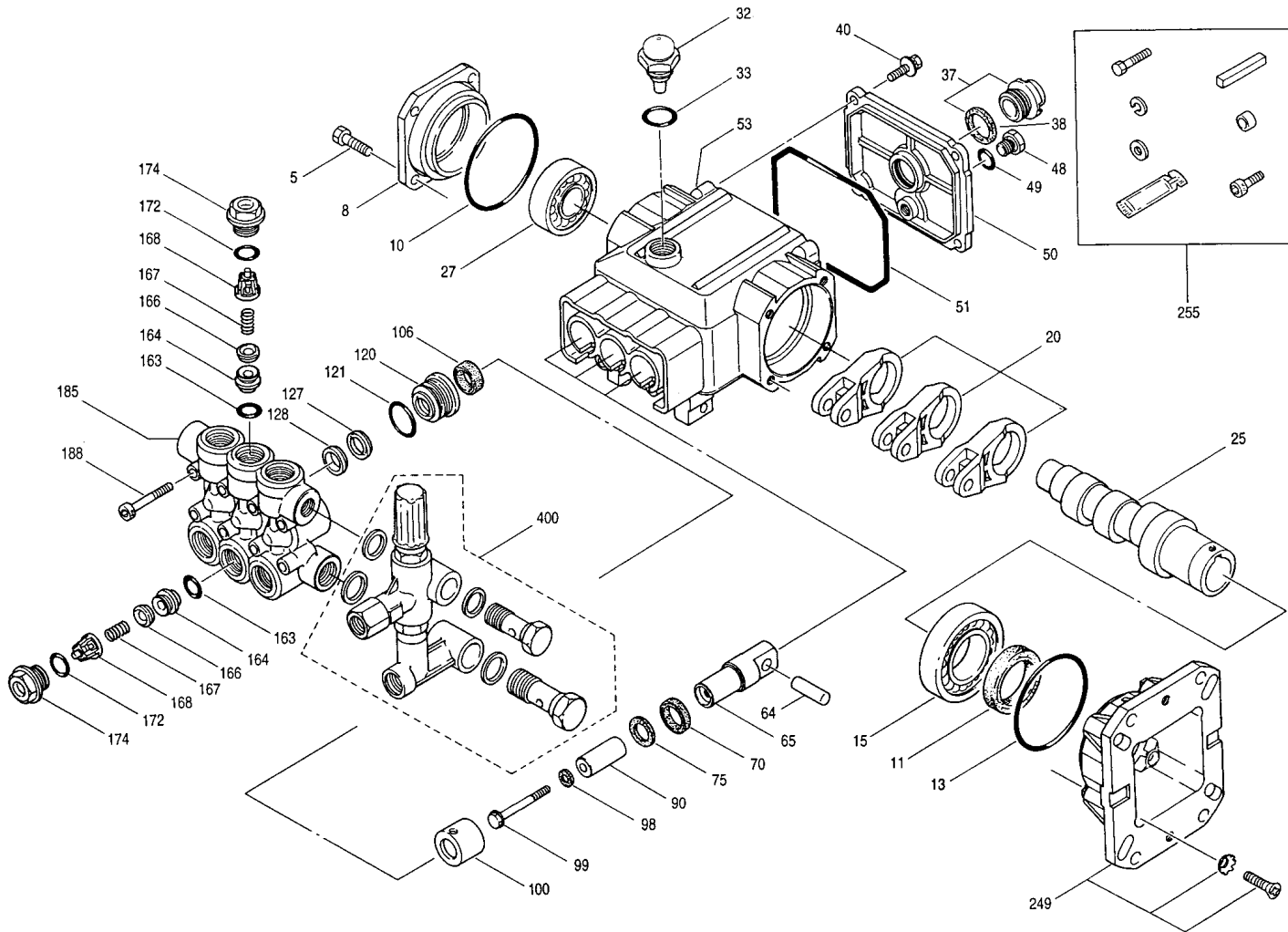

PARTS LIST

ITEM	P/N	MATL	DESCRIPTION	QTY	ITEM	P/N	MATL	DESCRIPTION	QTY
5	92521	STZP	Screw, HHC (M8x20)	4	100	46408	NY	Retainer, Seal	3
8	46461	AL	Cover, Bearing	1	106	48222	NBR	Seal, LPS w/S-Spg	3
10	14037	NBR	O-Ring, Bearing Cover	1	120	46471	BB	Case, Seal	3
11	46419	NBR	Seal, Oil, Crankshaft	1	121	13980	NBR	O-Ring, Seal Case	3
13	14037	NBR	O-Ring, Bearing Cover	1	127	46617	SNG	V-Packing	3
15	146421	STL	Bearing, Ball - Inner	1	128	46618	NY	Adapter, Male	3
20	46677	ZZ	Connecting Rod	3	163	17547	NBR	O-Ring, Seat - 85D	6
25	46985	CM	Crankshaft (6.4 mm) 30G1	1	164	46658	S	Seat	6
	46551	CM	Crankshaft (7.9 mm) 35G1	1	166	46429	S	Valve	6
	46460	CM	Crankshaft (9.0 mm) 40G1	1	167	43750	S	Spring	6
	48468	CM	Crankshaft (11.2 mm) 50G1	1	168	46583	NY	Retainer	6
27	14480	STL	Bearing, Ball - Outer	1	172	17615	NBR	O-Ring, Valve Plug - 75D	6
32	46798		Cap, Domed Oil Filler	1	174	46388	BB	Plug, Valve	6
33	14179	NBR	O-Ring, Oil Filler Cap - 70D	1	185	46526	BB	Head, Manifold	1
37	92241		Gauge, Oil Bubble w/Gasket - 80D	1	188	87868	STZP	Screw, HSH (M8x107)	8
38	44428	NBR	Gasket, Flat Oil Gauge - 80D	1	249	46679	AL	Flange, Adapter	1
40	92519	STZP	Screw, Sems (M6x16)	4		46123	STZP	Lockwasher, Conical (M8)	4
48	25625	STCP	Plug, Drain (1/4"x19BSP)	1		46403	STZP	Screw, FH (M8x25)	4
49	23170	NBR	O-Ring, Drain Plug - 70D	1	255	30519	STZP	Kit, Bolt Mount	1
50	46379	AL	Cover, Rear	1		34100	STZP	Screw (3/8-16x1-3/8")	4
51	14048	NBR	O-Ring, Rear Cover	1		30921	STZP	Lockwasher, Split (3/8")	4
53	46454	AL	Crankcase	1		30980	STZP	Washer, Flat (3/8")	4
64	46404	CM	Pin, Crosshead	3		6106		Antiseize Lubricant	1
65	46728	BBCP	Rod, Plunger	3		45217	STL	Key (1/4"x1/4"x2-1/2") HD	1
70	29257	NBR	Seal, Oil, Crankcase	3		34042	AL	Spacer	4
75	46732	NBR	Slinger, Barrier	3		87788	STZP	Screw, Set (M5x8)	1
90	46727	CC	Plunger (M16x47)	3	300	34062	NBR	Kit, Seal (Incls: 98,106,121,127,128)	1
98	46730	NBR	Washer, Seal	3	310	34260	NBR	Kit, Valve (Incls: 163,164,166,167,168,172)	2
99	48201	SS	Retainer, Plunger	3	400	7655	BB	Modular Unloader Assembly	1

Italics are optional items.

See Tech Bulletins 02, 24, 36, 43, 55, 60, 74 and 83 for additional information.

MATERIAL CODES (Not Part of Part Number): AL=Aluminum BB=Brass BBCP=Brass/Chrome Plated CC=Ceramic CM=Chrome-moly
 NBR=Medium Nitrile (Buna-N) NY=Nylon S=304SS SNG=Special Blend (Buna) STCP=Steel/Chrome Plated STL=Steel STZP=Steel/Zinc Plated ZZ=Zamac

7655 UNLOADER

Specifications	U.S. Measure	Metric Measure
GPM	2.0-5.0 GPM	(7.6-19 L/M)
PSI.....	700-3200 PSI	(50-220 BAR)
Inlet Port - Side	1/2" NPTF	(1/2" NPTF)
Discharge Port - Front.....	3/8" NPTF	(3/8" NPTF)
Weight	31.7 oz.	(0.89 kg)
Dimensions.....	3.25 x 1.5 x 6.37"	(76 x 38 x 162 mm)

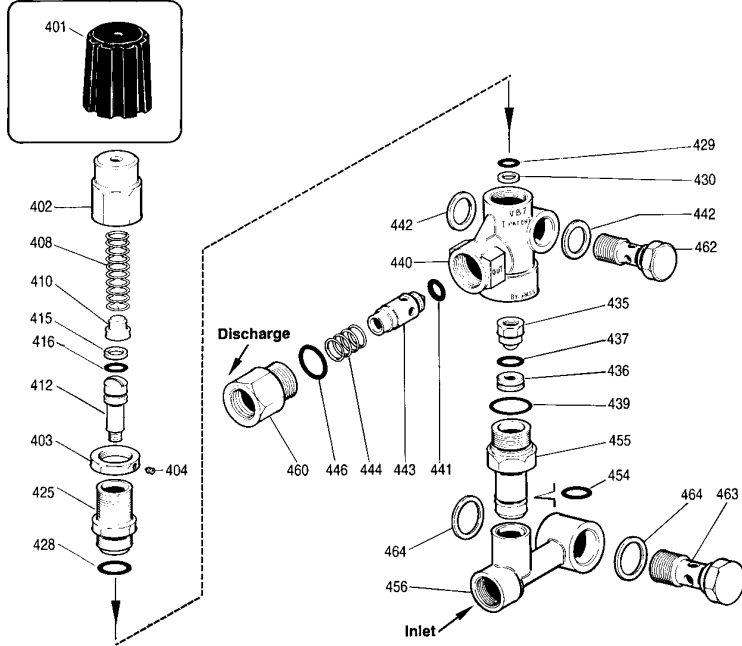

PARTS LIST

ITEM	P/N	MATL	DESCRIPTION	QTY.
401	32088	NY	Cap, Black	1
402	33859	BB	Cap, Hex Adjusting	1
403	33857	BB	Nut, Locking (M18x1)	1
404	33061	STZP	Screw, Set (M4x4)	1
408	33294	STZP	Spring	1
410	32819	BB	Retainer, Spring	1
412	33860	S	Stem, Valve	1
415	33278	PTFE	Back-up-Ring, Stem	1
416	33571	NBR	O-Ring, Stem	1
425	33861	BB	Retainer, Piston	1
428	33043	NBR	O-Ring, Retainer	1
429	33571	NBR	O-Ring, Stem	2
430	33276	PTFE	Back-up-Ring, Stem	1
435	33853	SSS	Valve and Ball Assembly (M6)	1
436	33806	NBR	Seat, w/O-Ring	1
437	—	FPM	O-Ring, Seat - 85D	1
439	—	NBR	O-Ring, By-pass Fitting - 85D	2
440	—	BB	Valve Body	1
441	—	NBR	O-Ring, Flow Balancer	1
442	33856	STL	Washer, Seal (3/8")	2
443	33852	BB	Valve, Check	1
444	33843	S	Spring, Valve, Check	1
446	33043	NBR	O-Ring, Discharge Fitting	1
454	—	FPM	O-Ring, By-pass Fitting	1
455	33863	BB	Fitting, By-pass	1
456	33850	BB	Manifold, By-pass (1/2" NPT)	1
460	33855	BB	Fitting, Discharge (3/8" NPTF)	1
462	33892	BB	Screw, Flow-thru (3/8" NPT)	1
463	33894	BB	Screw, Flow-thru (1/2" NPT)	1
464	33854	STL	Washer, Seal (1/2")	2
468	33098	NBR	Kit, O-Ring	1
—	33920	BB	Thermo Valve 140°F	1

Italics are optional items.

MATERIAL CODES (Not Part of Part Number):

BB=Brass FPM=Fluorocarbon (Viton®) NBR=Medium Nitrile (Buna-N)
 NY=Nylon PTFE=Pure Teflon® S=304SS SSS=416SS
 STL=Steel STZP=Steel/Zinc Plated

Adjustable CHEMICAL INJECTORS

Specifications	U.S. Measure	Metric Measure	U.S. Measure	Metric Measure
MODEL	7223		7224	
Flow	3.0-4.0 GPM	(11.4-15 L/M)	4.0-5.0 GPM	(15-19 L/M)
Nozzle Orifice	2.1 mm	(2.1 mm)	2.3 mm	(2.3 mm)
Hose Barb	1/4"	(1/4")	1/4"	(1/4")
Inlet Port.....	M22x1.5	(M22x1.5)	M22x1.5	(M22x1.5)
Discharge Port	3/8" NPTM	(3/8" NPTM)	3/8" NPTM	(3/8" NPTM)
Weight	6.3 oz.	(0.18 kg)	6.3 oz.	(0.18 kg)
Dimensions.....	2.0x1.0x3.0" (50x25x76 mm)		2.25x1.0x2.63" (57x25x67 mm)	

Fixed CHEMICAL INJECTORS

Specifications	U.S. Measure	Metric Measure	U.S. Measure	Metric Measure
MODEL	7233		7234	
Flow	3.0-4.0 GPM	(11.4-15 L/M)	4.0-5.0 GPM	(15-19 L/M)
Nozzle Orifice	2.1 mm	(2.1 mm)	2.3 mm	(2.3 mm)
Hose Barb - Ext....	1/4"	(1/4")	1/4"	(1/4")
Hose Barb - Int....	8/32" UNCF	(8/32" UNCF)	8/32" UNCF	(8/32" UNCF)
Inlet Port.....	M22x1.5	(M22x1.5)	M22x1.5	(M22x1.5)
Discharge Port	3/8" NPTM	(3/8" NPTM)	3/8" NPTM	(3/8" NPTM)
Weight	6.3 oz.	(0.18 kg)	6.3 oz.	(0.18 kg)
Dimensions.....	2.0x1.0x3.0" (50x25x76 mm)		2.25x1.0x2.63" (57x25x67 mm)	

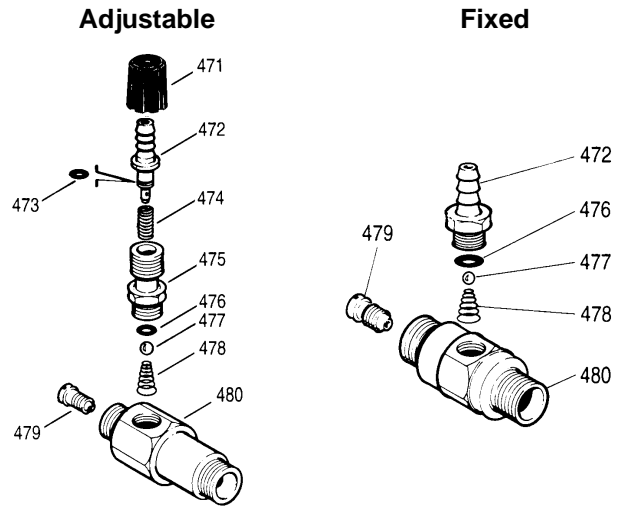

PARTS LIST

ITEM	P/N	MATL	DESCRIPTION	MODEL USED	QTY.
471	32940	BB	Collar, Adjustment	7223, 7224	1
472	32941	BB	Barb, Adjustable	7223, 7224	1
—	33505	BB	Barb, Fixed	7233, 7234	1
473	—	NBR	O-Ring, Hose Barb	7223, 7224	1
474	33500	S	Spring	7223, 7224	1
475	—	BB	Ball/Seat Retainer	7223, 7224	1
476	33504	FPM	O-Ring, Retainer	All Models	1
477	34620	SS	Ball	All Models	1
478	33501	SS	Spring	All Models	1
479	32373	S	Injector Orifice (2.1 mm)	7223, 7233	1
—	32374	S	Injector Orifice (2.3 mm)	7224, 7234	1
480	—	BB	Body, Unloader Mount	—	1
—	33480	BB	Fixed Barb Assembly	7233, 7234	1

Italics are optional items.

MATERIAL CODES (Not Part of Part Number):

BB=Brass FPM=Fluorocarbon (Viton®) NBR=Medium Nitrile (Buna-N)
 NY=Nylon S=304SS SS=316SS

CHEMICAL INJECTOR PERFORMANCE CHART

Desired Pump Flow	Orifice Size	Injector Model	Lo-Pressure Nozzle (Maximum injecting pressure less hose friction loss)	Max. Chem. Draw (0 PSI) (Downstream)	Hi-Press Nozzle "Deduction" (Press drop across Inj.)
3.5	2.1 mm	7223, 7233	300 PSI	50 oz/min	200 PSI
3.5	2.3 mm	7224, 7234	185 PSI	56 oz/min	175 PSI
4.0	2.1 mm	7223, 7233	375 PSI	54 oz/min	250 PSI
4.0	2.3 mm	7224, 7234	225 PSI	50 oz/min	225 PSI
5.0	2.3 mm	7224, 7234	300 PSI	50 oz/min	350 PSI

INSTALLATION:

A Modular Regulating Unloader comes with each 5DX pump to provide system pressure regulation and pump protection. The Unloader is mounted directly onto the pump with flow-thru screws.

On systems over 2000 PSI SECONDARY PROTECTION is recommended by installing a pop-off valve, safety valve or rupture disk.

An optional, specially ported, Chemical Injector may be installed directly onto the discharge of the unloader. Remove the discharge fitting, o-ring check valve and spring from the unloader. Insert check valve and spring into the injector and thread onto the unloader. **Discard the o-ring and discharge fitting.**

OPERATION:

Set the unloader while the high pressure system is turned on. Adjust in small increments until the desired system pressure is reached. Install a pressure gauge to check pressure during start-up and periodically during operation.

If unit is infrequently used or periodically stored, seals may become dry. Check seals before commencing operation.

The system must be purged before operation (system liquid must flow through the pump without discharge restriction) to assure full system pressure is reached.

Optimum performance of chemical injector occurs with a 35 ft. high pressure hose and a minimum 3/8" I.D. The type of hose, extended lengths, reduced I.D. and fittings may create back pressures in excess of the low pressure nozzle rating and prevent the injector from drawing chemical. See Hose Friction Loss Chart in Service Manual. **Deduct hose friction loss from above low PSI Nozzle. Consult factory for assistance with other options.**

CAUTION:

Deduct the pressure drop shown in the performance chart from your desired system pressure to arrive at the maximum high pressure nozzle rating. This is essential to avoid over-pressurizing the pump.

Chemical draw occurs under low pressure. Select the Change over Nozzle (32149), Adjustable Nozzle (32151), or Vari-Nozzle (7940-7980) to permit the adjustment from low to high pressure.

For optimum performance when using a chemical injector, use a **single wire braid hose** on the discharge line. Too flexible a hose will prevent the unloader from receiving the full pressure signal to activate the by-pass mode.

For correct nozzle selection, **read system pressure at the pump. DO NOT READ SYSTEM PRESSURE AT THE HIGH PRESSURE GUN.** Incorrect pressure reading may result in: pump operation at excessive pressures, inconsistent chemical draw or possible damage to the pump or unloader.

5DX DIMENSIONAL

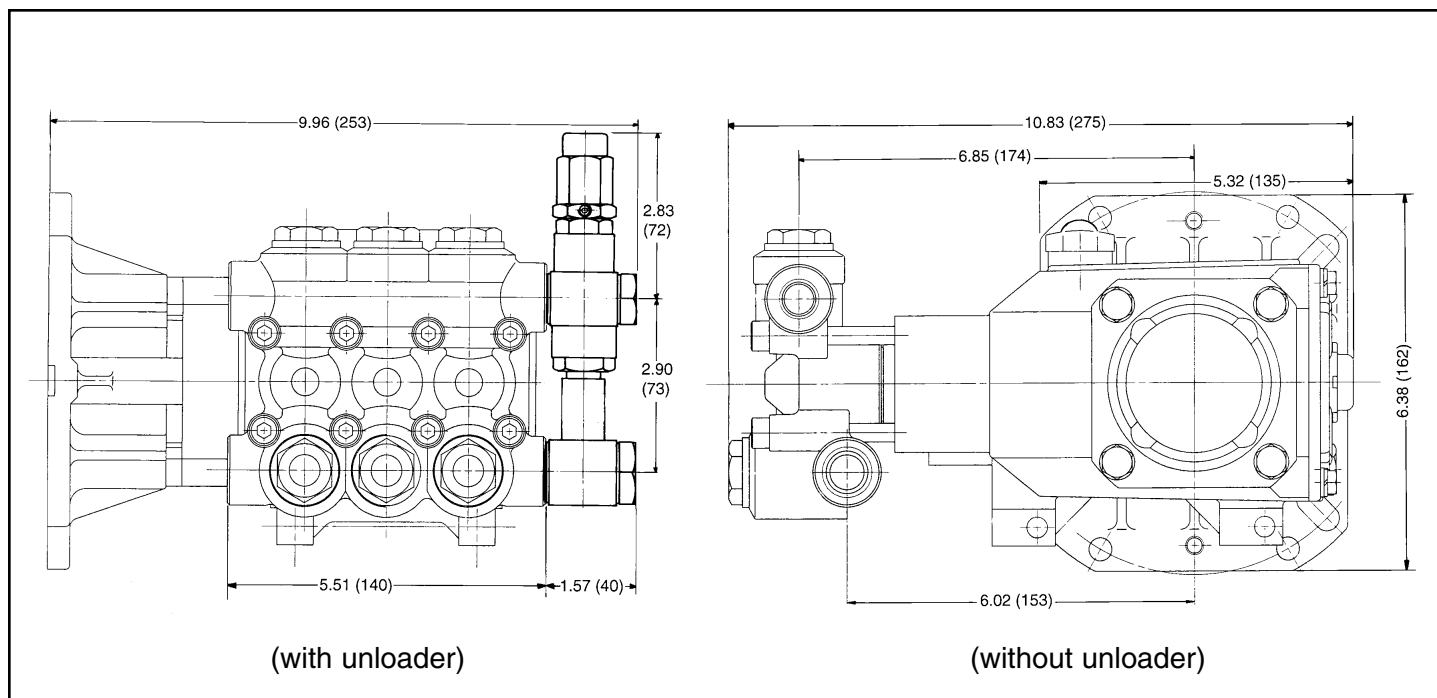

Feb 2001 2114

World Headquarters

CAT PUMPS

1681 - 94th Lane N.E. Minneapolis, MN 55449-4324

Phone (763) 780-5440 — FAX (763) 780-2958

e-mail: sales@catpumps.com

www.catpumps.com

International Inquiries

FAX (763) 785-4329

e-mail: intlsales@catpumps.com



"The World's Most Dependable Pumps"

CAT PUMPS (U.K.) LTD.

1 Fleet Business Park, Sandy Lane, Church Crookham, Fleet

Hampshire GU52 8BF, England

Phone Fleet 44 1252-622031 — Fax 44 1252-626655

e-mail: sales@catpumps.co.uk

N.V. CAT PUMPS INTERNATIONAL S.A.

Heiveldekens 6A, 2550 Kontich, Belgium

Phone 32-3-450.71.50 — Fax 32-3-450.71.51

e-mail: cpi@catpumps.be www.catpumps.be

CAT PUMPS DEUTSCHLAND GmbH

Buchwiese 2, D-65510 Idstein, Germany

Phone 49 6126-9303 0 — Fax 49 6126-9303 33

e-mail: catpumps@t-online.de www.catpumps.de